



Gc
942.5401
T741
v.1
1290052

GENEALOGY COLLECTION



AN INVENTORY
OF THE
CHURCH PLATE OF LEICESTERSHIRE,
WITH
SOME ACCOUNT OF
THE DONORS.

Of this work not more than three hundred and twelve copies have been printed, of which this is No. 198.

AN INVENTORY
OF THE
Church Plate of Leicestershire,

WITH
SOME ACCOUNT OF
The Donors.

BY
THE REV. ANDREW TROLLOPE, B.A.,
RECTOR OF EDITH WESTON.



In Two Volumes.

Vol. I.



De
942.5401
T.74i
v.1

"—Good ye are and bad, and like to coins,
Some true, some light, but every one of you
Stamped with the image of the Ring."
The Holy Grail.

Leicester:
CLARKE AND HODGSON, 5, GALLOWTREE GATE.

1890.

[All rights reserved.]

1290952



TO THE
MEMORY

OF

ARTHUR

AND

ELIZABETH

TROLLOPE,

MARRIED

AT

St. Mary's,
Bryanston Square,

London,

22ND JULY, 1845.



BORN

AT

Cascwick, co. Lincoln,
11TH JULY, 1810.

DIED

AT

Eastgate, Lincoln,
19TH JANUARY, 1880.



BORN

AT

Edith Weston, co. Rutland,
15TH FEBRUARY, 1822.

DIED

AT

Eastgate, Lincoln,
4TH OCTOBER, 1877.

LIST OF SUBSCRIBERS.



No. of
Copy.

1. THE MOST REV. EDWARD WHITE BENSON, D.D., D.C.L., Archbishop of Canterbury.
2. HIS GRACE CHARLES CECIL JOHN MANNERS, DUKE OF RUTLAND, K.G., Lord-Lieutenant of Leicestershire. (Ob. 4th March, 1888.)
3. THE RIGHT REV. WILLIAM CONNOR MAGEE, D.D., D.C.L., Bishop of Peterborough.
4. THE VEN. ASSHETON POWNALL, M.A., F.S.A., Archdeacon of Leicester. (Ob. 24th Nov., 1886.)
5. SOCIETY OF ANTIQUARIES OF LONDON, Burlington House.
6. ROYAL ARCHEOLOGICAL INSTITUTE OF GREAT BRITAIN AND IRELAND, Oxford Mansion, London, W.
7. Lieut.-Col. JAMES W. BAILLIE, J.P., Ilston Grange, Leicester.
8. BENJAMIN BALDWIN, Market Place, Loughborough.
9. The Rev. MORDAUNT BARTON, M.A., R.D., Tickencote Rectory, London.
10. The Rev. T. C. VERMUYDEN BASTOW, M.A., Peatling Parva Rectory, Lutterworth.
11. The Rev. Canon W. BERESFORD BEAUMONT, M.A., R.D., Cole Orton Rectory, Ashby-de-la-Zouch.
12. The Rev. EVANS BELCHER, M.A., Heather Manor, Ashby-de-la-Zouch.
13. Lieut.-Col. GEORGE C. BELLAIRS, J.P., The Newarke, Leicester.
14. The Rev. JAMES NOBLE BENNIE, L.L.D., R.D., Glenfield Rectory, Leicester.
15. The Rev. HENRY JOHN BIGGE, M.A., The Bury House, Cottingham, Uppingham.
16. FRANCIS EDWARD BIGGE, Hennapyn, Torquay.
17. HENRY SEVERN BLACK, Frisby-on-the-Wreake, Leicester.
18. Sir FRANCIS G. M. BOILEAU, Bart., F.S.A., Ketteringham Park, Wymondham, Norfolk.
19. BOSTON PUBLIC LIBRARY, U.S.A.
20. The Rev. PERCY HARRIS BOWERS, M.A., Market Bosworth Rectory.
21. Miss JULIA BOYD, Moor House, Leamside, Durham.
22. GEORGE VERE BRAITHWAITE, J.P., Edith Weston Hall, Rutland.
23. THOMAS BROOKE, F.S.A., Armitage Bridge House, Huddersfield.
24. THOMAS BROOKS, Barkby Hall, Leicester.
25. The Rev. GEORGE BOLNEY BROWN, M.A., Aston Vicarage, Stone, Staffs.
26. The Rev. WILLIAM EDWARD BUCKLEY, M.A., R.D., Middleton Cheney Rectory, Banbury.
27. The Rev. HENRY EVERARD BULLIVANT, M.A., Lubenham Vicarage, Market Harborough.
28. LIBRARY of Clare College, Cambridge.
29. EDWARD CONDER, J.P., Elm Hurst, Romford.
- 30-31. Mrs. CORRANCE, Nassau House, Syston, Leicester (2 copies).
32. JOHN HARRIS COOPER, J.P., Evington Hall, Leicester.

No. of
Copy.

33. Miss CREWE, 13, Queen's Gate Gardens, South Kensington.
34. Lady HARPUR CREWE, Spring Hill, East Cowes, I.W.
35. Miss HARPUR CREWE, Spring Hill, East Cowes, I.W.
36. HUGO HARPUR CREWE, Hemington, Leicestershire.
37. WILFRED JOSEPH CRIPPS, C.B., F.S.A., Cirencester.
38. The Rev. GEORGE CROSSLEY, M.A., Breton Vicarage, Ashby-de-la-Zouch.
39. NATHANIEL CHARLES CURZON, J.P., Lockington Hall, Leicestershire.

40. The Rev. JOHN DENTON, M.A., The Vicarage, Ashby-de-la-Zouch.
41. The Rev. FREDERICK BINLEY DICKINSON, M.A., Lillington Avenue, Leamington.
42. Sir HENRY EDWARD LEIGH DRYDEN, Bart., F.S.A., Canons Ashby, Northants.
43. The Right Hon. The Earl of DYSART, Buckminster Park, Leicestershire.

44. JAMES ROBERT EDMONDS, Fairfield, Carew Road, Eastbourne.
45. The Rev. EDWARD ELMHIRST, B.A., Shawell Rectory, Leicestershire.
46. The Right Rev. Lord ALWYNE COMPTON, D.D., Bishop of Ely, The Palace, Ely.
47. JOHN EVANS, P.S.A., D.C.L., LL.D., Nash Mills, Hemel Hempstead.

48. EDWARD FALKENER, J.P., Glanymor, St. Clear's, co. Carmarthen.
49. THOMAS McALL FALLOW, M.A., F.S.A., Coatham House, Redcar.
50. The Rev. JAMES FARMER, LL.B., The Crescent, Leicester.
51. The Rev. GERALD CHARLES FENWICKE, B.A., Blaston Manor, Uppingham.
52. The Right Hon. Earl FERRERS, Staunton Harold, Ashby-de-la-Zouch.
53. EDWARD FISHER, F.S.A. (*Scot.*), Abbotsbury, Newton Abbot.
54. The Rev. WILLIAM GEORGE DIMOCK FLETCHER, M.A., F.S.A., St. Michael's Vicarage, Shrewsbury.
55. AUGUSTUS WOLLASTON FRANKS, C.B., F.R.S., F.S.A., British Museum.
56. WILLIAM JESSE FREER, Stonygate, Leicester.
57. The Rev. WILLIAM THOMAS FREER, M.A., R.D., Houghton Rectory, Leicester.
(Ob. 14th Oct., 1889.)

58. The Rev. EDWARD RICHARD GARDINER, M.A., Radwell Rectory, Baldock.
59. The Rev. NIGEL GRESLEY, B.A., Nether Seale Rectory, Ashby-de-la-Zouch.
- 60-62. HENRY GRAY, 47, Leicester Square, London, (3 copies).

63. JOSEPH HAMES, Rotherby Hall, Leicester.
64. The Rev. THOMAS HANBURY, M.A., Church Langton Rectory, Market Harborough.
65. THOMAS HARDCASTLE, Blaston Hall, Uppingham.
66. Admiral HARDINGE, 32, Hyde Park Square, London.
67. The Rev. Canon GEORGE TYSON HARVEY, M.A., F.S.A., Vicars' Court, Lincoln.
68. Mrs. PERRY HERRICK, Beau Manor Park, Loughborough.
69. Miss HEYCOCK, East Norton, Leicester.
70. The Rev. THOMAS HEYCOCK, M.A., Seaton Rectory, Rutland.
71. ROBERT CHARLES HOPE, M.A., F.S.A., Albion Crescent, Scarborough.
72. W. H. St. JOHN HOPE, M.A., F.S.A., Society of Antiquaries, Burlington House, London.
73. JOSEPH JACKSON HOWARD, LL.D., F.S.A., (*Maltravers Herald Extraordinary*), 3, Dartmouth Row, Blackheath.
74. The Rev. JOHN CLARE HUDSON, M.A., Thornton Vicarage, Horncastle.
75. Mrs. W. HUNT, Holly Bank, Stoneycote, Leicester.

LIST OF SUBSCRIBERS.

ix

No. of
Copy.

76. The Rev. WILLIAM HENRY IGGULDEN, M.A., Browne's Hospital, Stamford.
(Ob. 11th Nov., 1888.)
77. The Rev. JOHN EDWARD ALEXANDER INGE, B.A., Gayton Rectory, Alford.
78. The Rev. CHARLES EDWIN JARVIS, M.A., Hatton Rectory, Wragby.
79. Mrs. C. E. JARVIS, Hatton Rectory, Wragby.
80. The Rev. HUGH BEAUMONT JONES, Vicarage, Frisby-on-the-Wreake, Leicester.
81. THOMAS JONES, Bradenham, Knighton, Leicester.
82. HARRY LEYCESTER POWYS KECK, J.P., Stoughton Grange, Leicester.
83. WILLIAM KELLY, F.S.A., Ivy Lodge, Stoneygate, Leicester.
84. The Misses KING, Thurnby House, Leicester.
85. Major G. LAMBERT, F.S.A., Coventry Street, London.
86. The Ven. WILLIAM LEA, M.A., Archdeacon of Worcester. (Ob. 24th Sep., 1889.)
87. LEICESTERSHIRE ARCHITECTURAL AND ARCHAEOLOGICAL SOCIETY.
- 88-89. LEICESTERSHIRE BOOK SOCIETY (*2 copies*).
90. LEICESTER FREE LIBRARY.
91. DEAN AND CHAPTER LIBRARY, Lincoln Cathedral.
92. LINCOLNSHIRE AND NOTTINGHAMSHIRE ARCHITECTURAL AND ARCHAEOLOGICAL SOCIETY.
93. LIVERPOOL FREE PUBLIC LIBRARY.
94. The Rev. HENRY JOSHUA LOMAX, M.A., Stoke Golding Vicarage, Hinckley.
95. ALEXANDER McARTHUR, M.P., Raleigh Hall, Brixton Rise, London.
96. MESSRS. MACMILLAN AND BOWES, Trinity Street, Cambridge.
97. The Rev. ARTHUR ROWLAND MADDISON, M.A., F.S.A., Vicars' Court, Lincoln.
98. The Rev. CHARLES ROBERTSON MANNING, M.A., F.S.A., Diss Rectory, Norfolk.
- 99-100. H. C. MOFFATT, J.P., Goodrich Court, Ross, Herefordshire (*2 copies*).
101. FREDERICK RICHARD MORLEY, Stonesby House, De Montfort Square, Leicester.
102. Miss L. MORRIS, Cranborne House, Bournemouth.
103. The Rev. JOHN HENRY T. M. DE MOWBRAY, M.A., R.D., Knossington Rectory, Leicestershire.
104. J. E. NIGHTINGALE, F.S.A., The Mount, Wilton, Salisbury.
105. EDWARD NIXON, Savile House, Methley, Leeds.
106. Col. EDWARD ANDREW NOEL, Outwoods Hall, Duffield, Derby.
107. NORTHAMPTON AND OAKHAM ARCHITECTURAL SOCIETY.
108. The Right Rev. EDWARD TROLLOPE, D.D., F.S.A., Bishop of Nottingham, Leasingham Rectory, Sleaford.
109. The Rev. HORACE WILLIAM ORFORD, M.A., Bradden Rectory, Northamptonshire.
110. The Rev. THOMAS WILLIAM OWEN, M.A., St. Nicholas' Vicarage, Leicester.
111. Miss PACKE, Asherne, Dartmouth.
112. HUSSEY PACKE, J.P., Prestwold Hall, Loughborough.
113. Lieut.-Col. FREDERICK PALMER, J.P., Withcote Hall, Oakham.
114. Sir GEOFFREY PALMER, Bart., East Carlton Park, Northants.
115. The Rev. WILLIAM HENRY PALMER, M.A., Wanlip Rectory, Leicester.
116. The Rev. THOMAS CROSS PEAKE, M.A., Hallaton Rectory, Leicestershire.
(Ob. 5th Aug., 1889.)
117. MATTHEW PEARSON, Frisby-on-the-Wreake, Leicester.

- No. of
Copy.
118. The Right. Hon. HENRY GEORGE, Earl Percy, F.S.A., Alwick Castle.
119. Mrs. PHILLIPS, Fernleigh, Leicester.
120. The Rev. THOMAS PITTS, M.A., R.D., The Rectory, Loughborough.
121. The Rev. WILLIAM HENRY POCHIN, Worminghall Vicarage, Thame.
122. RICHARD RATCLIFF, J.P., Stanford Hall, Loughborough.
123. The Rev. ARTHUR MEDLAND RENDELL, M.A., St. Margaret's Vicarage, Leicester.
124. The Rev. JOHN BIRCH REYNARDSON, M.A., Careby Rectory, Stamford.
125. The Rev. FREDERIC HENRY RICHARDSON, M.A., R.D., The Vicarage, Belgrave.
(Ob. 6th Aug., 1887.)
126. The Rev. Canon W. A. SCOTT ROBERTSON, M.A., Throwley Vicarage, Faversham.
127. J. P. ST. AUBYN, Chy-an-Eglos, Marazion, Cornwall.
128. Lady CHARLOTTE SCHREIBER, Langham House, London.
129. SCIENCE AND ART DEPARTMENT, South Kensington Museum.
- 130-35. CHARLES TOLLEMACHE SCOTT, J.P., Bosworth Park, Leicestershire (6 copies).
136. CONINGSBY CHARLES SIBTHORP, J.P., Canwick Hall, Lincoln.
137. Miss WALDO SIBTHORP, Minster Yard, Lincoln.
138. Mrs. WALDO SIBTHORP, Minster Yard, Lincoln.
139. Mrs. BROADLEY SMITH, Castle Hill House, Tutbury.
- 140-41. Messrs. J. and T. SPENCER, Market Place, Leicester (2 copies).
142. JOHN STAYNES, Market Place, Leicester.
143. The Rev. FRANCIS STERRY, M.A., Poltimore Rectory, Exeter.
144. The Rev. ARTHUR FREDERICK SUTTON, Brant Broughton Rectory, Newark.
- 145-47. General Sir CHARLES TROLLOPE, K.C.B., 21, Grosvenor Square, London (3 copies).
(Ob. 5th July, 1888.)
148. Mrs. TROLLOPE, Leasingham Rectory, Sleaford.
149. ALFRED TROLLOPE, South Wynaad, East Indies.
150. Miss J. E. TROLLOPE, Edith Weston Rectory, Stamford.
151. J. HORSFALL TURNER, Idel, Bradford.
152. The Rev. Canon HENRY TWELLS, M.A., Thornleigh, Bournemouth, Hants.
153. Major-Gen. H. T. VACHELL, Mercia House, Lansdowne Road, Brighton.
154. The Rev. Canon HENRY LACON WATSON, M.A., R.D., Sharnford Rectory, Hinckley.
155. Capt. THOMAS CHARLES DOUGLAS WHITMORE, J.P., Orsett Hall, Romford, Essex.
156. JOHN HEATH WILLIAMS, J.P., Knighton Park Road, Leicester.
157. GEORGE NEWTON WING, Melton Mowbray.
- 158-60. RICHARD HENRY WOOD, J.P., F.S.A., Penrhos House, Rugby (3 copies).
161. WORCESTER FREE PUBLIC LIBRARY, Mass., U.S.A.
162. The Rev. CHARLES FRANCIS WYATT, M.A., Broughton Rectory, Banbury.



PREFACE.



THE notion of making a catalogue of the church plate in this county was originally due to the example of Chancellor **R. S. Ferguson**, F.S.A., who in 1882 brought out, with the help of his colleagues, "*Old Church Plate in the Diocese of Carlisle*." In common with others engaged in following that excellent lead, I found the way made feasible by adopting as a "road book" "*Old English Plate*," by Mr. **W. J. Cripps**, C.B., without which a six years pleasant tour along this unexplored path of antiquarian Leicestershire could probably never have been undertaken.

It is needless to dwell on the use of such a catalogue; its value is apparent to all taking interest in the parochial history of their county, to ecclesiologists, heralds and genealogists, as well as to lovers of old silver plate. The object however with which this work was first commenced was a strictly conservative one; it was hoped that an inspection of the church plate in each parish, followed up with a printed inventory, would be the means of causing church officers to refrain from parting with their ancient treasures. The cry had been heard from many counties that too often ancient vessels had been exchanged for new. It is a satisfaction to think that in more than one Leicestershire parish this inspection has been made in time to discourage an exchange of that kind, which cannot by-the-by be legally effected without the consent of the Diocesan.

Whilst indulging in the boast that each piece of plate named in this catalogue has been examined by myself, I should not like it to be thought that I have not had the advantage of much kindly assistance. A work of this nature relating to church goods in every parish in a county is itself a witness to the courtesy of the Clergy, shown in their readiness to give every help and information in their power. In thinking of the many times that extracts from parish records have been freely sent at my request I cannot do less than ask here to be allowed to thank my brethren in Leicestershire for all the kindness they have shown me. Thanks are due for the same help given by many clergy outside this county and diocese.

I am much indebted to the owners of private chapels within the county, one and all of whom have readily allowed me to describe and illustrate the sacred vessels in their possession.

A special acknowledgement is due to Mr. **Matthew Pearson**, of Frisby-on-the-Wreake, for the constant help that he has never failed to render with his skilful pen and pencil. As of other portions of the work, the labour devoted to his share has been far greater than the inexperienced might suppose. I wish to thank him most heartily for those many industrious hours that he has spent, throughout several years, in illustrating these pages. I am also indebted to Miss **F. H. Morton** for similar assistance.

In spite of failings, apparent enough to its compiler, a hope is entertained that this inventory may not be without its use to Leicestershire folk, now living and yet to come.

A. T.

EDITH WESTON RECTORY,
September, 1890.



CONTENTS OF VOL. I.

	PAGE.
ADDITIONS AND CORRECTIONS 	xxxì
INTRODUCTION 	i
INVENTORY OF CHURCH PLATE IN AKELEY WEST DEANERY 	1
" " " AKELEY EAST " 	36
" " " CHRISTIANITY " 	75
" " " FRAMLAND I. " 	111
" " " FRAMLAND II. " 	127
" " " FRAMLAND III. " 	150
" " " GARTREE I. " 	178
" " " GARTREE II. " 	199
" " " GARTREE III. " 	228
" " " GOSCOTE I. " 	254
" " " GOSCOTE II. " 	285
" " " GUTHLAXTON I. " 	310
" " " GUTHLAXTON II. " 	334
" " " GUTHLAXTON III. " 	357
" " " SPARKENHOE I. " 	374
" " " SPARKENHOE II. " 	400

LIST OF ILLUSTRATIONS IN VOL. I.

Woodcuts by MR. J. D. COOPER.

FIG.		PAGE.
1	Chalice with Cover, at Ashby-de-la-Zouch	3
2	Arms of Earl of Huntingdon	4
3	Arms of Bainbrigge	12
4	Chalice, at Grimston	40
5	Dish, at Wanlip	67
6	Chalice, at Woodhouse	69
7	Arms of Hacket	87
8	Arms of Wyggeston	92
9	Agate Ewer, at Belvoir Castle	113
10	Rose Water Dish, ,, ,,	114
11	Arms of Michell , impaling ——— ?	120
12	Arms of Cooke	125
13	Acorn Cup, at Stapleford	138
14	Arms of Ingram , impaling Sherard	139
15	Arms of Sherard , impaling Reeve	139
16	Chalice with Cover, at Waltham	145
18	Arms of De la Fontaine	161
19	Arms of Smith and Pate	171
20	Arms of Cox ? impaling ——— ?	177
21	Crest of Cradock	183
22	Arms of Palmer , impaling Grantham	202
23	Arms of Parker	219
24	Arms of Armston , impaling Noel and Wigley	220
25	Chalice, at Blaston St. Giles	233
26	Paten, at Great Easton	235
27	Crest of Morris	241
28	Paten, at Tugby	248

LIST OF ILLUSTRATIONS.

xv

FIG.		PAGE.
29	Arms of Wilson , impaling Chester	249
30	Arms of Parker , impaling Wilson	252
31	Arms of Ashby	264
32	Chalice and Cover Paten, at Twyford	266
33	Chalice, at Launde Abbey	272
34	Crest of Cecil	273
35	Paten, at Ratcliffe-on-the-Wreake	297
36	Paten, at Syston	302
37	Chalice, at Wymeswold	307
38	Monogram, G.A.H.	310
39	Chalice with Cover, at Braunstone	321
40	Seal of the City of Lichfield	327
41	Arms of Wright , quartering Onebye	336
42	Crest of Wright	337
43	Arms of Boothby	360
44	Arms of Falkener , impaling Falconer	371
46	Arms of Lord Crewe , impaling Foster	386
47	Chalice, at Gopsal	397
48	Arms of Abbot Eucharius Weiner	398
49	Chalice, at Higham	408
50	Cover Paten, at ditto	409
51	Arms of Viscount Wentworth	411
52	Arms of Noel , impaling Whitlock	412
53	Arms of Noel , impaling Cranmer	412
54	Flagon, at Market Bosworth	414
55	Arms of Dixie , impaling Willoughby	415
56	Arms of Dixie , impaling Atkins	415

Relief Blocks by **TYPOGRAPHIC ETCHING CO.**

17	Flagon, at Wyfordby	147
45	Chalice and Cover Paten, at Nailstone	383
57	Chalice, at Shenton	418

INTRODUCTION.

Origin of communion plate now in existence.

TO get at the origin of services of communion plate that now exist we must go back to pre-Reformation days, the records of which time show that church plate was the free gift of individuals, sometimes of the parishioners combined, and occasionally of a guild or other corporation within the parish. The names of the donors of plate are often recorded in medieval inventories of church goods, the compilers of such documents naturally enough noting the donor in order that the piece named might be all the better identified. Of course this could only be done provided the piece of plate bore an inscription or had been very recently given; the absence of those conditions often prevented any possibility of naming the giver. A well-known example of a medieval inventory of church goods in which donors' names are mentioned is one that was drawn up for the Archdeaconry of Norwich, from 1368—1407, by Archdeacon **William de Swyneflete** and his successors, in which are many such entries as these:

Plate given to churches in medieval times by various donors

St. Peter of Mancroft, Norwich. "One silver gilt cup, given by **William de Wymondham**." "One silver gilt cup, given by **Richard de Bittering**."

St. Andrew, Norwich. "Item, one coupe for the body of Christ, gilt & enamelled, good & precious, given by **William Luminour, Margaret Fairchilde & William Apelyard**." "Two silver patens, given by **Margaret Fairchild**." "One silver gilt chalice, given by the parishioners." "One new chalice, given by St. Andrew's Guild."*

Such gifts were made in pre-Reformation days by individuals in death as well as in life, as the wills of those times testify. Here are a few examples of bequests of plate to churches within this county:

Plate bequeathed to churches in medieval times

Henry, Duke of Lancaster, in his will made 15th March, 1360, and proved III. Cal. April, 1361 (Islep, 172a, *Lambeth Palace*), entered these clauses:

* *Norfolk Archaeology*, Vol. v., p. 89. For other inventories in which donors are named see those of *St Margaret Pattens*, 1470—1526, printed by Mr. W. H. St. John Hope, F.S.A., *Archæological Journal*, Vol. xlii, p. 312

"Nre corps a estre enseuellits en légglise Collegial de Annúciacion nre dame de Leicestr* d'autrepart le autiere ou le corps nre seigneur et pierre que dieu assoile est enterrez. Voloms et devisoms que toute la cire et tous les drapes d'or demoergent a la dite eglise colligial et devisoms a la dite eglise entierement nre Chapele ove tous les aournements et tous nos religes."

"Our body to be buried in the Collegiate church of the Annunciation of our Lady of Leicester, on the opposite side of the altar where the body of our lord and father, whom God pardon, is buried. We will and bequeath that all the wax and all the cloths of gold shall remain in the said Collegiate church, and we bequeath to the said church entirely our Chapel with all the ornaments and all our relics."

William, Lord Ferrers, of Groby, in his will made 1st June, 1368, and proved XIV. Cal. Aug., 1372 (Whittleseye, fo. 124b, *Lambeth Palace*), bequeaths:

"Corpus meū ad sepelliēd in ecc^a bte Marie de Uluescrofte. Item lego suūo altari eiusdem ecclie melius vestimentū meū cū capa & omībs ptinentī de secta eiusdem. It lego p̄dco altari meliorē calicem meū argēt deaurāt duas meliores folias argēt & vnū vas p̄ aqua bndcā cū asporio argēt. . . . It lego fabricē ecclē de Wodh^m fferers† xls. It lego suūo altari eiusdem ecclē vnā coppā cū coopclo deaurāt dupplici opis ad depinēd dco altari p̄ corpe xī imponēd & importānd & imp̄nā ibā remanēd."

"My body to be buried in the church of the blessed Mary of Ulverscroft. Item; I leave to the high altar of the same church my better vestment with a cope and all other priest's vestments of the same suit. Item; I leave to the aforesaid altar my better silver gilt chalice, two better silver cruets and one vessel for holy water with a sprinkle of silver. . . . Item; I leave to the work of the church of Woodham Ferrers xls. Item; I leave to the high altar of the same church one cup with a cover gilt of double work to serve for the said altar to contain and carry the body of Christ, and there to remain for ever."

William Hastings, Lord Hastings, in his will made 27th June, 1481, and proved P.C.C. 12th Aug., 1483, orders:

"That there be given by my executors to the parish church of Ashby-de-la-Zouch a suite of vestments with an autercloth according with the colour of the same vestments by the discretion of them. And a chalice to the same church to the value of 100s. of lawful money."

Isabell Sapcote, widow of Sir **Richard Sapcote**, Knt., of Burley, co. Rutland, in her will made 30th July 1493, and proved P.C.C. 10th July, 1494, bequeaths:

"To the prior of Launde & his successors a pax with two crewetts of sylver to pray for my soule. . . . I will that there be wared *xli*. upon a standing coope & no lesse and be gevin to the howse of Spalding‡ to pray for my soule. Also I will that the howse of Crowland‡ have a standing coope price *xli*. Also I will that the howse of Sweneshed‡ have a standing coope price viii. marc."

* This church stood in the Newark, Leicester, and was demolished in the reign of Elizabeth: Henry, Earl of Lancaster, was buried on the North side of the altar; his son, the testator, on the South: for some account of its foundation see *Nichols' Hist. of Leicestershire*, Vol. i., p. 329. † In Co. Essex. ‡ Co. Lincoln.

William Nevell, of Carleton, co. Northampton, Esq., in his will made 24th Aug., 1497, and proved P.C.C. 15th Dec., 1498, bequeaths:

"To the house of the Abbey of Land all my plate there to remaine & abyde for ever. . . I restore to the chappell of Holtt a chalys of selver."

Agnes Atkinson, in her will proved at Leicester in 1526, leaves:

"To Saint Denny's Chappell in Harborow one goblet off sylver and a peysse."

William ffyshier, Master of the Hospital of "**Wylliam Wygston** the younger," in his will made 15th Dec., 1534, and proved in Leicester, bequeaths:

"To the beyd howse chapell my iiij best candystycks."

Many similar bequests can be found in printed collections of wills; *e.g.*, in "*Early Lincoln Wills*,"* from which useful little book we learn that **Thomas Lufwyk**, rector of Burton Noveray, † leaves in 1390, to Lufwyk ‡ parish church,

"my best silver zone to make a chalice."

Such was the origin of church plate in medieval times. And what has become of it all? How is it that in this county with the exception of some half-dozen pieces there is no piece of church plate older than the reign of **Elizabeth**? This is an oft-told tale, and shall not occupy more words than are necessary in the telling of it once more. §

One of the choicest pickings clawed hold of by **Henry VIII.** and his fellow plunderers upon the dissolution of a monastery was its store of gold and silver plate. That theft of monastic plate must have indirectly greatly lessened the security of the sacred vessels, often of considerable value, belonging to parish churches. An evil example of plunder had been set, which can hardly have been left without imitators. But that plunder of monastic plate chiefly affected the fate of the goods of parish churches through the feeling of the insecurity of church goods that was thus placed in the minds of church officers themselves, who would otherwise have taken good care of their treasures; but now, naturally began by degrees to say, "our turn will come next:" and they had all the more reason for their fears when the policy of plunder had actually gained a foothold within their parish churches, by the grant by Parliament of the chantries to the King in 1545. And so we find parish vestries, in that and the following years, parting with a portion of their church plate before it could be seized, as did the vestry of St. Martin's, Leicester (p. 88), and spending the proceeds on the repair of their churches. When the chantries were finally dissolved in the second year of **Edward VI.**, such chantry plate as had not already been thus sold was seized by the King.

Sacrilege becomes fashionable.

Parish Vestries sell some of their plate

* Edited by Mr. Alfred Gibbons. Williamson, Lincoln, 1888. † Co. Leicester. ‡ Co. Northants. § See *Old English Plate*, p. 152; also *Notes on Elizabethan Communion Plate*, Rev. J. Fuller Russell, *Archæological Journal*, Vol. xxxv., p. 42.

*More plate
sold after
Injunctions of
Edward VI.*

In the first year of **Edward VI.**, 1547, further encouragement was given to church officers to part with surplus goods by the issue of the King's injunctions, and the visit of his Commissioners to each county to inquire if those injunctions had been enforced; they were armed with articles of inquiry, of which this was one: "Whether there do remain not taken down in your churches, chapels, or elsewhere, any misused images, with pilgrimages, clothes, stones, shoes, offerings, kissings, candlesticks, trindles of wax, and such other like; and whether there do remain not delaid and destroyed any shrines, coverings of shrines, or any other monument of idolatry, superstition, and hypocrisy?"* Their visit to Melton is thus recorded in the accounts: †

"1547. Itm. y^e 9 Octobre, p^d ffor a pottill wyne given the King's visitors vij*d*."

Church plate is not referred to in that article, but needy vestries did not fail to find in it an excuse for the sale of pieces of plate not actually wanted, especially if the parishioners were ultra-reformers; money, moreover, had to be found for alterations in church furniture ordered by the injunctions. An instance of such a sale made at that time is to be found in the accounts of the same churchwardens, who parted in 1547-8, with various pieces of plate, together with the images of the rood loft, the sepulchre case, etc., condemned by the King's injunctions; (p. 165).

*First
inventories of
Edward VI.
stop further
sale of plate*

This hurried parting with church plate by the parishioners themselves caused the King and his advisers to again appoint Commissioners for every county early in the following year, 1548, to see once more that the injunctions were enforced, and also to make inventories of church goods, with a view to stopping any further sale. Their visit to Melton is thus recorded in the Churchwardens' accounts:

"1547-8. Itm. p^d ffor a payll of wyn given the comyssyre when he came to touk of the churchwardens ffor the church goods vij*d*."

"Itm. paid at Leic. the iij^d day of M̄che ffor charge of they churchward^{ns} at the delyvre off they byll upp before y^e King's... xx*d*."

And to St. Martin's, Leicester, thus:

"1548-9. Itm. p^d to Raf Clark for makyng y^e inventory of y^e Church goods vij*d*."

"Itm. p^d to Wiłm Lyllers for registryng of the same vij*d*."

As far as it has been possible to learn, no further record of the visit of the King's Commissioners to this county in 1548 has been preserved; neither have any of the inventories of Leicestershire church goods, then made, been brought to light.

* Cardwell's *Documentary Annals*, 1844, Vol. i., p. 25. † *Transactions of Leicest. Archæol. Soc.*, Vol. iii., p. 184.

The stock-taking effected in each parish by the King's Commissioners probably put a stop to any further sale of sacred vessels, but it by no means frightened churchwardens out of their now well-established custom of raising money for church purposes by the sale of other church goods; their accounts teem with large items received for valuable vestments, altar furniture, brass, bells, etc.; the disposal of such goods being all the more hastened by the change of ritual now introduced. Such sales took place in every parish up to the end of this reign: when at last in the sixth year of **Edward VI.**, 1552, his ministers determined to step in and seize all that they could, and to get back the value of some of the goods already sold; this being one of their devices for raising money to pay the King's debts.* With this object Commissioners were again sent into every county and town with precise instructions: first, to find out what plate, jewels, and ornaments had been sold in each parish since the issue of the first commission, and to extort the value of those goods from those who had received the price of them: secondly, to learn what goods each parish still possessed, taking away all the plate except one chalice in a small and two in a large parish, and selling copes and vestments of any value. They were instructed to deliver over all plate and money so received to the King's use, and to cause exact inventories to be made of all goods finally left behind in each parish.†

The Commissioners for Leicestershire secured £170 6s. 5d. in ready money for goods sold since the first commission, and took away from the different churches 515 oz. of plate; they sold no vestments, apparently finding none worth taking. (*Appendix B*, Vol. ii., p. 447). Their visit to Melton is recorded in these three entries in the Churchwardens' accounts:

" 1553. Itm. p ^d to good wyffe Frearche for wyne for Mast ^r Newell and Mast ^r Cave.....	xijd."
" Itm. payd the xxij daye of Maye to Master frauncis Cave for our byll‡	vjd."
" Itm. payd to the Commyssyoners (xx daye of Julye) for y ^e church goodes.....	iiijli."

This last entry shews that the Commissioners for the county did not finish their work until after the date of the King's death, 6th July, 1553. The Commissioners for the town of Leicester were equally late in getting possession of money for goods sold by parishioners: as is shewn in this entry in the St. Martin's churchwardens' accounts: §

" 1553. Itm. p ^d to the Quenes comissioners for the cope of tyssue that were solde	viiijli."
---	-----------

* "For the devise to paye the dett at November." 1552, in Sir W. Cecil's hand-writing; see *Hist. MSS. Commission. Cecil MSS.*, Pt. i., p. 99. † For full information relating to this Commission, see *7th Report of Deputy Keeper of Public Records*, p. 307, and *9th Report*, p. 233. ‡ Bill indented inscribed with inventory of Goods left in possession of the Church. § Edited by Tho. North, F.S.A. S. Clarke, Leicester, 1884.

Of the inventories that were made of goods left in the possession of each church, we have only those of the parishes in Framland and in the west part of the hundred of Goscote. (*Appendix A*, p. 433.) In these two deaneries four churches only had two chalices left to them; four were altogether without a chalice, one of which, Whitwick, had had its chalice stolen; perhaps the other three had suffered the same loss.

Small amount of church plate at the end of King Edward's and throughout Queen Mary's reign.

At the end of King **Edward's** reign all the plate that each church usually possessed was "one chalice of silver," which would include the paten, and also sometimes a pix, two candlesticks, two cruets, a cross and censer, of pewter, latten, or some base metal. A replacement of utensils that had been parted with was made in the next reign; but all repurchasing was naturally done on economical principles; the vessels bought by order were of base metal. No church benefited by the inquiry made in the middle of Queen **Mary's** reign into the doings of the late King's Commissioners; (*Appendix B*, Vol. ii., p. 445), for that strict questioning was instituted not in order that any goods might be returned, but that some knowledge might be gained of the disposal of the plate and money that had been "lifted" in the late reign. In spite of ritual changes the only silver vessel belonging to a church being, as a general rule, the one silver chalice and paten, left behind by the Commissioners of **Edward VI.**

In early years of Elizabeth, only one chalice and paten existed out of ancient gifts of silver plate.

And that one chalice is all that is found in the early years of **Elizabeth's** reign, when the time came for it also to be taken away; not this time by the plunderer, but by the Puritan. There was a strong desire to declare once for all that the church in England had at last cast away superstitions that had crept in under Roman influence and marred the purity of her doctrine. The ultra-reforming majority thought that to do this completely it was necessary to destroy in every church certain utensils and ornaments; the ancient chalice being one. Consequently, first in one diocese, then in another, the order went forth that the medieval chalice should be exchanged for a "decent communion cup."

That one exchanged for an Elizabethan chalice.

In Leicestershire this exchange was begun in several parishes in 1567, and effected in most of the rest within the following seven or eight years. (*Appendix F*, Vol. ii., p. 475.) In this county, and probably in the whole of the great Lincoln diocese,* the chalice was about the last of the ancient ornaments to be chosen for destruction. No order relating to its exchange has, as yet, been found in the Bishop of **Lincoln's** registers; but the MS. book endorsed "Iventarium monumentum superstitionis," printed by Mr. **E. Peacock**, in his "*English Church Furniture*," † reveals the ultra-reformers at work a few months earlier within this diocese. That party found

* Then composed of the counties of Lincoln, Leicester, Huntingdon, Bedford, Buckingham, and a small portion of Hertford. † *J. C. Hotten*, London, 1866.

a vigorous head in **John Aylmer**, Archdeacon of Lincoln from 1562-77,—“an active and bold man, as well as wise and learned,”—who made his influence felt outside the limits of his Archdeaconry. He “lived in great reputation in Lincolnshire” as a Justice of the Peace, and one of the Queen’s Ecclesiastical Commissioners: and in the execution of that commission, as well as in preaching, shewed such energy that not one recusant was left in the county at his departure for the See of London; where, it is only fair to say, he attacked Puritans and Papists with equal vigour. From that little which is told us by **Strype** of his work in the diocese we may conclude that the Archdeacon of Lincoln was the leader in the hunt after “Monuments of Superstition.” The “Inventarium,” printed by Mr. **Peacock**, shews that the Archdeacon and other Commissioners had sent in 1565-6 to the churchwardens of each parish a list of “Monuments of Superstition” under different headings, such as rood loft, mass books, altar stones, etc., and had ordered them to certify which of those articles their church had possessed since the death of Queen **Mary**, and how, when and where such things had been destroyed. The MS. book is a list of inventories sent from Lincolnshire parishes in reply to that order,—shewing the “Monuments of Superstition” owned by each church since 1558, and certifying to their destruction. The chalice is named in barely a dozen of these inventories, and does not seem to have been included in the inquiry. This search was probably made simultaneously throughout the whole diocese; at any rate, it extended into Leicestershire, as is shewn by these entries in churchwardens’ accounts: †

*Search after
“Monuments
of Supersti-
tion”*

St. Martin’s, Leicester, 1566. “It. payd at the vysytacyon for the sworne menn dynners and ours	ijs.”
“It. payd for puttyng out the Imageyse out of the pulpyte.....	iiijd.”
St. Margaret’s, Leicester, 1565. “For takyng down of the Roode lofte ...	8d.”
“Received for the Holy water Stoke	8d.”
Melton, 1566-7. “Itm. p ^d ffor ow ^r charges & marsements at Leicest ^r ye xvi daye of february ffor y ^t ye Rood loft whas not takyn down & defasyed	iiijjs. iiijd.”
(April). “Itm. spent at Lecest ^r ye xxij daye ffor ye deleveryn off ow ^r Invettore off ow ^r chyrche goods	viiijd.”

In about a year later, 1567, the ancient chalice also was included amongst the monuments of superstition, and was ordered to be exchanged for a new communion cup and cover. That order was enforced probably through an article of inquiry at the Bishop’s visitation, repeated at subsequent visitations until the exchange had been effected in every parish. ‡

* *Life of John Aylmer*, by Strype, Oxford, 1821. † A careful comparison of Churchwardens’ Accounts from the five counties would show how far the Diocese was worked on a uniform plan. ‡ For such articles of inquiry, vide *Archæological Journal*, Vol. xxxv., p. 48.

The Elizabethan covered chalice represents an ancient benefaction.

We have now arrived at the origin of communion plate of Elizabethan date. An Elizabethan cup and cover represents a gift made in medieval days. The last silver vessel left behind by the spoilers was sold, and almost the same sum that it produced spent in the purchase of the Elizabethan chalice with its cover paten. A record of that exchange may be looked for in any set of churchwardens' accounts that exist of that date (pp. 82, 88, 165). The little cup and cover paten thus procured was the only vessel of silver in most churches throughout the whole of this reign; two pewter flagons, and pewter basins for the offertory, completed the service of even the largest church. Those were not the days for making gifts for sacred use. Most men had been brought up in the school of the spoiler; and the extreme Puritan felt no desire to adorn the sanctuary of God.

Little plate given in the reign of Elizabeth.

We must turn the century; and then, in the old way, the churchman once more offers gifts to his parish church. A stream of benefactions starts up at once and flows on continuously through nearly three centuries, only a little checked by the dam opposed to it in the troubles of the rebellion.

Gifts of plate offered once again early in the 17th century.

The earliest known gift of plate made to a church in this county in the 17th century is the cup and cover paten presented to Skeffington church in 1606, by **Katherine Skeffington** (p. 245); and the earliest known bequests of money for a similar purpose are three made in the year 1635: £10 left by **Samuel Hartopp** to Melton church (p. 168); and two sums left by **Margaret Abbott** and her son **Gabriel** to Lutterworth (p. 347). From then till now many have been the gifts of plate made, both in life and death, by benefactors to Leicestershire churches, as these pages amply shew; and, if each piece of plate could describe its own origin, it would probably be found that twice as many gifts have been made by individuals than those which it has been possible to record. Amongst those donors that have been identified all classes are represented, from a Queen downwards (p. 378). And, in addition to individual donors, parishioners, as in former years, have at times, united in a body to present their church with some sacred vessel, as at Belgrave (p. 258) and Burbage (p. 403).*

Characteristics in the shape of sacred vessels of pre-Reformation date.

Six pieces of pre-Reformation church plate.

Only six pieces of medieval church plate are to be found at the present time in the churches of this county—the communion cups of Blaston St. Giles and Wymeswold (pp. 233 and 307), and the patens at Great Easton,

* It must be remembered that when Churchwardens inscribed their names on a recent purchase, that piece as often as not represented a former gift, and frequently cost little more than the proceeds obtained by the sale of the older piece.

Tugby, Ratcliffe, and Syston (pp. 235, 248, 297, and 302). In addition to these there is the medieval cup in Mr. **Dawson's** private chapel at Launde Abbey (p. 272). The earliest piece is probably the Great Easton paten, *circa* 1350, (*Appendix F*, p. 475), which differs from others of that time in having the device of the Vernicle in its centre, and in the points of its eight lobes being extended to the central circle. Owing to these distinctions this piece cannot very readily be assigned to any of the classes in the valuable analysis of medieval plate drawn up by Messrs. **W. H. St. John Hope** and **T. M. Fallow**.* The cup at Launde falls within type F. of that analysis, having the deep conical bowl, hexagonal stem, ornate knob, and six-sided foot. In spite of this pretty piece having to all appearance been made out of two chalices, all parts seem to be of the same date (*circa* 1450), if anything perhaps a little earlier, judging from the style of the engraved tracery on the stem and knob; the scrips engraved on two lobes of the foot, and the devices with which they are charged, are of special interest. Next in date is the Tugby paten (*circa* 1480), which is classed very readily in their type D.; it has the second sexfoil depression, engraved spandrels, and the Vernicle in the centre. The Blaston St. Giles chalice (*circa* 1500) is mentioned in Messrs. **Hope** and **Fallow's** analysis, being classed by them in type F_B, with others of the same shape; its modern bowl, however, prevents a perfect agreement with the characteristics of that type. Of the same date (*circa* 1500) two patens next appear, from the neighbouring parishes of Ratcliffe-on-the-Wreake and Syston. That belonging to the former is also at once seen to be similar to others named in the same analysis, and to belong to type E., since it has the single circular depression, with the sacred monogram in black letter in its centre. The other, that at Syston, probably belonging to the same series, is unusually plain in shape and rudely beaten out. The latest medieval piece that we have in this county, the Wymeswold cup (1512), is the only one that has been hall marked. There is some doubt amongst experts as to the purpose for which this and others like it were originally made; the wide shallow bowl can scarcely have been designed for a cup; a ciborium or pix has been thought to have possibly been its original use. It is strange that even these few medieval pieces should have survived the search after "Monuments of Superstition;" perhaps the Wymeswold cup owed its safety to its plainness, and that at Blaston to the fact of its being in use in a donative; the four patens may have escaped through their insignificance.

General characteristics of Elizabethan chalices and patens.

A glance at the Elizabethan pieces figured on the different plates (Vol. ii.

* *Archæological Journal*, Vol. xliii., pages 136 and 364.

p. 523), shows that while there is a strong family likeness between vessels of that date, there is at the same time an infinite variety in their shape and ornament; no two cups are exactly alike except when made by the same maker, and even then a perfect match is seldom met with. Of cups stamped with the London assay marks and made by the same maker we have in this county, two at Twyford and Catthorpe (p. 266 and *Plate XXVII.*), his mark being "*I. P.*" in a shaped shield; and another pair at Wymondham and Loddington (*Plates XI. and XVIII.*) made by one whose mark was "*F. R.*" in monogram, in a shaped shield; at Hallaton and South Croxton (*Plates XV. and XIX.*) are two more, stamped with a fleur-de-lis, in a shaped shield; and at Foxton, Goadby Marwood, and Kimcote (*Plates XIII. and XXVII.*) there are three stamped with an oblong eight-pointed mark; ; these latter are indeed very nearly a perfect match. There has been some questioning as to the reason of this strong resemblance between Elizabethan pieces; there can hardly have been any other except that of custom; their shape was the fashion of the day, as it is now the fashion to attempt to imitate vessels of medieval date. The Bishops asked for "a comely communion cup with a cover;" it was the fashion of the day to produce such a one as that at Ashby (*Plate I.*), a good example of the usual shape of one stamped with the London hall marks. Those so marked are certainly the best both in shape and decoration; pleasing curves are displayed in their outline, both in bowl, stem, and foot; the sides of the former are often ogee-shaped, curved out nearly always into a bell-shaped lip, and well rounded off into the top of the stem. Good curves are seen again in the stem, which is generally evenly-balanced and something like a dumb-bell in shape; a bold round knob divides it in half, from thence it is curved well out into both ends. The foot is rounded at the top into a bold segment, sometimes into an ogee. The cover, rounded off like the foot of the cup, is so made that it fits both ways,—a rim underneath keeps it in its place as a cover; while its top is so curved that when necessary it rests on the lip of the cup with its foot downwards. Unfortunately, owing to its small size and the thinness of its metal, the cover paten has often been dissevered from the chalice. If there is any engraved ornament at all round the bowl of a cup stamped with London hall marks, it is nearly always one or more bands of foliage enclosed in straps covered with zig-zag lines, and divided into parts by curves of an hour-glass shape; a similar band is sometimes repeated on the top of the foot, and again on the cover. Further decoration is seen in little vertical reeds placed round both ends of the stem and round the foot, and in the egg and tongue ornament often found on the edge of the latter, and also occasionally just under the bowl; instead of the little reeds a lozenge-shaped ornament, allied to 15th century work, is sometimes used, as in the Bringhurst cup (*Plate XVIII.*) Now and then a London marked cup is found

No two Elizabethan cups exactly alike.



Cups stamped with London assay marks the best.

without any engraved band at all, as at Hallaton (*Plate XV.*), the plainness of the bowl being relieved with a raised moulding. In the three cups made by one maker (*Plates XIII. and XXVII.*), we also find a similar moulding taking the place of an engraved band; these three, as well as the Bringhurst cup, showing a further variety in having no knob to the stem.

Four groups of Elizabethan chalices stamped with maker's mark only.

Elizabethan cups stamped only with the maker's mark are very numerous in this county. We have first a group of seven, stamped only with the *leopard's face in a shaped outline*; ; these are at Wartnaby (*Plate V.*); Sproxtton, Saxby, Stonesby (*Plate X.*); Alexton, Tugby, (*Plate XVIII.*); and Sibley (*Plate XIX.*); to which may perhaps be added the Saltby and Edmondthorpe cups (*Plate X.*) At times a maker has not taken the trouble to stamp his work, and occasionally the mark has worn off. But however much an unmarked may resemble a marked piece, the two cannot be attributed with certainty to the same maker. This group, stamped with the *leopard's face*, resembles London hall marked pieces, in bold curves of outline and good finish, more closely than the three other groups stamped only by the maker. All nine cups are alike in having deep, plain, and nearly straight-sided bowls; in three only is a knob found in the stem; none have vertical reeds round stem or foot; the egg and tongue ornament round the latter is their only decoration. Only three of their covers have survived, two being as plain as the cups; that at Stonesby has a band of stroke ornament round its top. It is worthy of remark that all nine are found in the North-Eastern quarter of the county: six of them being in neighbouring parishes close to Melton. Perhaps all were procured through some silversmith of that town who ordered them from the same maker in London. If there had not been such a scanty survival of Elizabethan pieces in that northern corner of the county, more cups of this series would probably have been found there.

*Maker's
mark:
Leopard's face
in shaped out-
line*

A small group, stamped only by the maker, is made up with the Wyfordby, Goadby, and Walton cups (*Plates X., XV., and XXI.*), on each of which is what has been taken to be a *maiden's head coupéd at the shoulders, in a shaped shield, between "G N." or, N G.*" On the two first the mark is thus,— on the third thus,— The die was evidently made by a "prentice hand;" in the first example, the head is upside down, and the letters reversed; in the other case some alteration seems to have been made in the die, causing it to stamp the initials rightly, but sacrificing the head, which is hopelessly blurred. The Wyfordby cup is in every way like the first-mentioned group in shape, having the same deep plain bowl and short stem without a knob. The

*Maker's
mark Head
between G N*

Goadby cup would also have been just the same if its bowl had been rounded off into the stem, instead of being fixed into a shallow saucer, which forms a flat, projecting, and rather ugly base. The interesting little Walton cup is altogether different, being remarkably wide and dumpty in shape, with a broad band of foliage round its bowl and cover, and a bold round knob to its stem. Perhaps the maker of this little group was connected by partnership, or in some other way, with the maker using the *leopard's face* as his mark; for besides the resemblance of two out of the three to that group, each of the three parishes owning these cups abuts on a parish in which is found a piece stamped with the *leopard's face*.

Maker's
mark: Cross
between four
pellets in
dotted circle.

We have another little group of three cups, stamped only with a *cross between four pellets, in a dotted circle*; ; at Swepton, Dadlington, and Sutton Cheney (*Plates IV. and XXXI.*) In shape these are very similar to those in the large group to be described next; we miss in their outline the good curves displayed in London marked pieces. Each of these has a bowl very wide at the lip, and fixed at the base into a shallow projecting saucer, round the edge of which run roughly drawn lines. Like most London marked cups the stem is evenly-balanced, but does not curve out so well into the two ends, and the knob, instead of being bold and projecting, is very poor and shallow: the foot is rather wider than usual, owing to which and to the stem not swelling much out, it has a flat instead of a rounded appearance at the top. More ornament is to be seen on these three; engraved bands run round the bowl of each, and round the foot of two; the edge of the stem and foot are reeded. The Dadlington cup is a little different to the others, being one of those with a narrow neck and indented disk at the top of the stem, in place of the usual upper vertical end. This little group can be accurately dated, since "1573" is engraved on the latter cup, and "1577" on the cover of that at Swepton. It has been said that several pieces stamped with this mark have been found in the county of Warwick; in that case the town of Coventry may have been their place of manufacture, and a thorough search amongst the records of that borough might help to decide the point. There was one goldsmith, at any rate, of some note in that town in the middle of the 16th century, named **John Tallance**, to whom the parishioners of St. Martin's, Leicester, sold some of their plate in 1545 (p. 88). **John Tallance**, "goldsmith," was elected Mayor of Coventry in 1544, and again in 1562.

Maker's
mark: a
Rose.

The next group of pieces, stamped only by the maker, is the largest and perhaps the most interesting of the four. For want of a better name the mark of this maker has been called a *rose*; . On some pieces it has been fairly well stamped, and seems at first sight to be tolerably clear; but a close examination can make nothing out of it distinctly, though five irregular petals can at times be almost traced. This series consists of no less than seventeen

cups, some of which have covers, viz.: those at Lubenham, Church Langton (*Plate XIII.*); Thurnby, Welham (*Plate XIV.*); Billesdon (*Plate XV.*); Gaddesby, Thurmaston (*Plate XIX.*); Syston (*Plate XX.*); Witherley, Sheepy (*Plate XXX.*); Bosworth (*Plate XXXI.*); Belton (p. 9); Rearsby (p. 299); Heather (p. 380); Nailstone (p. 383); Carlton (p. 405); and Higham (p. 408). To these seventeen may be added, with more or less probability, the following, not stamped with any mark at all: Snibston, Blackfordby (*Plate I.*); Isley Walton (*Plate IV.*); Stoney Stanton (*Plate XXVI.*); Ashby Magna (*Plate XXVII.*); and Hugglescote (*Plate XXX.*) The whole of these, with the exception of two, are strikingly alike in shape: a little difference in measurement and in the design of the engraved bands is all the distinction that can be observed between them. A cup of this group is inferior, both in shape and construction, to one stamped with the London hall marks: for it has no fine curves, all its lines are too much inclined to be straight. The bowl has always concave sides, widening out more than usual at the lip. The whole bowl is not, as in a London marked cup, beaten out of one piece of metal, but is in every case fixed at the base into a shallow saucer with a turned-up projecting edge. The evenly-balanced stem is generally rather thick in appearance and always inclined to be straight, swelling out only a little at each end, and divided in half by a very poorly formed knob. The foot is a little wider than usual and is not so much rounded on the top. In every case there is an engraved band, more often of stroke ornament than of foliage, round the bowl: one of exceptional beauty and intricacy is to be seen round the cup at Syston (*Plate XX.*) One cup only of this series, actually stamped with the "rose," differs from the others in design, viz.: the one at Nailstone (p. 383), of which the stem is not evenly-balanced as usual, but urn-shaped, with an indented disk at the top and bottom. The unmarked cup at Isley Walton (*Plate IV.*), has much the same stem, but differs further in its shorter bowl having been beaten entirely out of one piece of metal, and so being without the saucer-like base. There seems to be some reason for concluding that these "rose" marked pieces were the work of a silversmith in Leicester; that town is in the centre of the part of the county in which they are found; their number and the inferiority of their design and construction mark them as being of local make. It was at one time thought that the "rose" might prove to be the Leicester cinquefoil, the arms of the borough being *Gules a cinquefoil Ermine*; but a close examination of each impression has failed to trace a distinct cinquefoil in any one of them. For want of more precise information all these pieces, with one exception, have been dated in *Appendix F* under "1575 (*circa*);" but it is quite probable that some were made later in that century, and one or two perhaps not until the beginning of the next. A reason for this conclusion is found in the late date "1608,"

engraved on the cover paten at Higham (p. 408), made, to all appearance, at the same time as the cup: this, alas, is the only dated cover paten of this series that has survived. Some parishes were doubtless late in obtaining an Elizabethan chalice of silver; a few may have been allowed to retain their medieval chalice unobserved for several years after the Bishop had ordered its exchange; and in the whole county there must have been about a dozen parishes that had no pre-Reformation chalice to part with, and could not therefore have been compelled to provide themselves with chalices of silver; and probably did not do so till late in the 16th or early in the 17th century. Some of these later purchases may have been made from the local silversmith using the "rose" as his mark.

Other forms of Elizabethan cups.

Two chalices, very different in shape to the usual Elizabethan piece, are to be seen at Grimston (p. 40) and at Leire (*Plate XXVI.*) The fine chalice at Melton, made in 1559 (*Plate XII.*), is one of a class met with now and then at this time: the bowl is rather shallower, and rests on a conical instead of on the usual evenly-balanced stem, near the top of which is a disk for a guide to the hand. This shape, in a plainer form, is met with very frequently in the first-half of the next century; an example dated 1630 is to be seen on the same plate; and a cup of similar shape, but without the disk, is often found to have been made between the restoration and the earlier years of the 18th century. Another type of Elizabethan chalice, made late in the reign, is one figured on *Plate XIV.*, dated 1601, with a V-shaped bowl and baluster stem; others, more or less like this, are met with during the next hundred and fifty years. In some cases the bowl is bell-shaped (*Plate XX.*); in others nearly straight-sided (*Plate XXVI.*)

Shape of church plate in the 17th century.

From the number of chalices and patens presented between 1630-40 (*Appendix F*), it seems that some churchmen in this county were influenced by Archbishop **Laud's** desire to have all the furniture of the altar comely and convenient. A common shape for the chalice at that time is a modified form of the usual Elizabethan cup,—a rather straight bowl, with evenly-balanced stem, entirely without engraved bands or any other ornament (*Plate XXI.*)

Though it is many years before the cover paten altogether goes out of fashion, a marked change is seen in the shape of many patens made in those years and earlier in the 17th century. It is now often a paten only, slightly sunk, resting on the lip of the chalice, and very like a plain medieval paten, with the addition of the convenient foot. With the exception of one of doubtful date at Grimston, our earliest example is Sir **W. Herrick's** gift to Woodhouse in 1610 (p. 69); which is also the first piece on which a donor's arms have been engraved.

*Paten often
no longer a
cover*

Out of that wish to have all things comely grew the desire to offer gifts to the altar of value and beauty. In a series of large and handsome vessels made in the middle of the 17th century, designed, in part at any rate, after medieval work, we have the expression of that intention. Of this series Leicestershire produces good examples in the two covered chalices and patens at Staunton Harold, 1640-54 (*Plate II.*): a service of great interest owing to its size, design, date and donor. In the hexagonal stem of each chalice, embossed knob and six-sided foot, is to be seen a distinct attempt to revive medieval design. The handsome cup and cover at Ashby, 1676 (p. 3), belongs to this series; and the eight-lobed foot of the Wyggeston Hospital chalice, 1668 (*Plate VIII.*) assigns that piece also to the same class. Perhaps to this revival could be traced the custom of placing the sacred monogram once again upon communion plate.

*Medieval
revival in
shape of
plate in
17th century.*

In about the middle of the 17th century the solid tankard-shaped flagon began to come into general use. We have not a single specimen of the jug-shaped Elizabethan flagon; * the only piece approaching to that in shape being the pewter one at Lubenham, 1635 (*Plate IX.*) Our earliest silver tankard is the one at Lockington (*Plate VI.*), which was made in 1612, but not given to the church till 1638: the year in which the next in date was made for Melton. From then the tankard-shape was adopted for the next two hundred years; with rare exceptions, like the fine silver gilt jugs at Market Bosworth, 1712 (p. 414); and those at Rolleston, 1737 (p. 232); Swithland, 1757 (*Plate VII.*); Kirkby Mallory, 1768 (*Plate XXXIII.*); and Sapcote, 1799 (p. 348). The earlier tankards made in the latter half of the 17th century can generally be recognized by the lid, shaped like a befeater's hat, and by the drum swelling widely out at the foot (*Plate XXXIII.*); while those made in the next century have usually a dome-shaped lid and narrower foot, ending in an ovolo moulding (*Plate VIII.*) Owing to their very plainness, and to the amount of silver at once seen to have been used in their construction, there is something stately in the appearance of these tankards. Their shape has been very unnecessarily found fault with, and too frequently made

*The tankard-
shaped flagon.*

*Jug-shaped
flagon ex-
ceptional*

* For illustrations of which see *Old English Plate*, p. 181, and *Church Plate in Kent*, Part i., p. 20.

the reason for an exchange, generally effected at a loss to the church in the weight of silver. Unless of abnormal size, like the one at Ashby (p. 4), a tankard-shaped flagon is not in the least inconvenient to use with one hand only, if properly held, not that there is any reason why it should not be taken in both when necessary.

Style of church plate in the 18th century.

*Salvers with
gadrooned
edges.*

At the end of the 17th and in the early part of the 18th century a good plain piece of plate, often of high standard silver, is met with in several churches, fashioned after the shape of a salver then in use; a flat dish with a gadrooned edge, resting on a hollow foot with its edge similarly moulded. Our earliest is Mr. **Henley's** gift to Melton, 1694 (*Plate XII.*) Sometimes this shape was adopted for a paten, and at times for a ciborium, so called.

An 18th century communion service is distinguished for its very solid construction rather than for anything particularly pleasing in design. In a service of that date the weight of silver devoted to this sacred purpose is at once seen to have been large. Each piece is of thick metal, and there is an increase in their number; one piece being sometimes a large handsome alms dish, like that on *Plate XII.* A good 18th century service, without the latter, is that given to Ilston by Sir **A. Heselrige** in 1758 (*Plate XVI.*)

In the 19th century.

*Imitation of
medieval work
not satisfactory*

Glancing at *Appendix F* (p. 485), gifts of church plate in the 18th century are at once seen to have been very numerous.—Perhaps as many have already been offered in the 19th. The costliness of many recent gifts and the devotional spirit in which all have been offered, will always cause modern pieces of church plate to be highly valued: in design and workmanship they have no special interest. The treatment of church plate coincides with that of the fabric of the church. Anything good and artistic in the design and execution of a sacred vessel is simply in proportion to the faithfulness with which some ancient specimen has been copied. The imitation of medieval plate is often found to have been very superficially made; and in general appearance even a fairly faithful reproduction loses greatly by the mechanical way in which it has been manufactured; the marks of the hammer and all the little irregularities left of old by the silversmith's tools are terribly missed. Not a few modern pieces are too light in weight to survive the wear and tear of much use. This determination to imitate medieval examples must

check the growth of original and artistic work, for no room is left for anyone but the copyist. May the goldsmith once again become an artist, and his best work the gift of faithful men and women to God's sanctuary.

Secular Pieces of Plate.

A benefactor has sometimes given, or bequeathed, a piece of plate to a church out of his own plate chest. We have several interesting examples of such gifts in this county, but not so many as some would suppose. Sometimes one may hear it said that, as a matter of course, a coat of arms on a piece of plate marks it as having been once used for secular purposes: while some will assert that because a chalice has been fashioned after the shape of the drinking cup of the period it cannot have been made for a church. Such suppositions are quite contrary to fact. To find either a chalice or paten of secular origin is very unusual: nearly all were specially made for sacred use. The usual gift from a donor's own store has been either a flagon or dish for a ciborium, so called. If a secular cup has been presented it is generally found to be one of special value and beauty, which the owner has wished to dedicate to the use of his church, as at Stapleford (p. 138); and at Braunstone (p. 321). To the former Lord **Harborough** bequeathed the acorn cup; and to the latter, the hanap, a contemporary piece, has been given by some unknown donor. With these may be classed two other chalices, once of secular use, which are to be found at Peatling Magna (*Plate XXVIII.*); and at Shenton (p. 418): each piece is a tazza; the one at the latter place being the gift of Sir **William Chester**, Bart. The little beaker at Ragdale (*Plate XXI.*), and the salver, used as a paten, were both probably once possessed by Earl **Ferrers**. We have two other silver patens, once of secular use, in Mrs. **Bradgate's** bequest of a salver to Scraftoft (p. 219), and in Mr. **Wotton's** gift to Bowden Magna (p. 178). At Swinford (p. 355), is a trencher plate given for a paten by Sir **Thomas Cave**; and we have another at Knighton (p. 108), the gift of Sir **E. C. Hartopp**, Bart. Of tankard-shaped flagons there are three in this county that once were secular pieces of plate: **J. Bainbrigg's** gift to Lockington (p. 20); **T. Holme's** gift to Woodhouse (p. 70); and the Garthorpe flagon (p. 135). In addition to these, two pair of handsome silver jugs, made of very thick metal, have been given to serve the purpose of flagons; one pair, made in 1715, to Foston and Ratby churches (*Plate XXV.*), by **Charles** and **Anne Boothby**; the other very similar pair of 1728, (*Plate IX.*), to Edmondthorpe, by Mrs. **Smith**; and then there is the silver jug given to Queniborough, by **J. P. Hungerford**, (p. 278.) Of salvers given to serve the purpose of credence patens there are; Mr. **Tacey's** gift to Quorndon, (p. 56); the dish given to Eastwell, by the

*Secular plate
not given to
Churches as
often as some
have supposed.*

Rev. J. Knipe, (p. 130); and the salver at Tugby, (p. 249), given by Mr. **Wilson**. At St. Martin's, Leicester (p. 87), are two trencher plates given by **P. Hacket**, with a good engraved coat of arms at the back; and at Thorpe Satchville (p. 267), two more, pentagonal in shape, the gift of **G. Williamson**; a similar plate was given to Bosworth, by **Frances Dixie**, (p. 415). The two standing cups and two tazzas, mentioned above, were set apart for sacred use because specially prized by their owners; for the same reason we find two good pieces of secular plate given to Barrow-on-Soar, and Sheepshed (*Plates IV. and VI.*): the former being Mrs. **Utber's** fluted porringer, and the latter, a two handled cup bequeathed by Mr. **Heath**. Since the main part of the large service at Swithland was made for the church we may well conclude that the two charming candlesticks of high-standard silver, and pair of little engraved trays (*Plate VII.*), were taken by Sir **John Danvers** from plate in his own possession. Of course the most beautiful of all the few once-secular pieces of plate catalogued in these pages are the lovely agate ewer and dish belonging to the Duke of **Rutland** (p. 113). Before leaving this subject it should be mentioned that in recent years a certain number of pieces of plate, once of secular use, have been bought for different churches. Though such pieces have not the same interest about them as plate given by a donor out of his own chest, they are, in some instances, well deserving of notice. There is the basin-shaped dish at Leire with the Tudor rose embossed in its centre (*Plate XXVI.*); and at Lutterworth are several costly pieces, formerly to all appearance secular plate (p. 346).

Foreign Plate.

Owing to the dissolution of religious houses on the continent a good deal of foreign church plate has found its way into English hands within the present century. Through that cause chiefly, a few such pieces have been described in this work. There are in this county at least four pieces of German make: the beautiful chalice belonging to Earl **Howe**, set with jewels, and painted enamels, stamped with the Augsburg assay mark (p. 397); the plainer chalice of similar shape, belonging to Mr. **Dawson** (p. 273); the little repoussé dish at Wanlip (p. 67); and the chalice at Waltham, stamped both with the Augsburg and Nuremberg assay marks (p. 145). To these may be added the medieval chalice at Launde Abbey (p. 273); and the charming little acorn cup at Stapleford (p. 138), which may possibly have passed into the possession of the **Sherards** as soon as it was made. A piece of plate of Spanish make is to be seen in the silver jug at Wanlip (p. 67); the second silver dish in that church was probably made in the same county.

Pewter Vessels—their date and origin.

In medieval times various utensils and ornaments, in the poorer churches especially, were made of base metal such as latten, brass, or copper gilt; the two cruets were generally of pewter; but neither those nor any other pewter vessels survived the Reformation changes in this county (*Appendix G*, p. 505).

No medieval vessels of pewter left, nor any of those made in the 16th century

At the end of the reign of **Edward VI.** only a few churches in Leicestershire seem to have possessed cruets at all (*Appendix A*, p. 434); and those that still existed were of pewter, none of silver. Cruets of silver were doubtless the very vessels that had been chosen in more than one parish for sale, as being most easily spared, when church officers took to selling their church's ornaments (p. 165). Those of silver that had not been thus parted with were taken away by King **Edward's** Commissioners. In 1554, one of Bishop **Bonner's** articles of inquiry in his visitation of the London diocese was, "Whether the things under-written (which are to be found on the cost of the parishioners), be in the church;" amongst which things are "two cruets;"* so that most churches that had been left without those vessels at the end of **Edward's** reign were provided with pewter cruets in the reign of **Mary**. But the very fact of that provision having been made under Papist influence would cause the two cruets to be looked upon by the ultra-reformers of the next reign as "monuments of superstition." In any case we find them so classed in the diocese of Lincoln, as may be learnt from the uniform record of their destruction in every parish included in the "*Inventarium*" of 1565-6.† No very ancient vessels of pewter therefore need be looked for in any of our Leicestershire churches. A few of the larger churches of the county may have been provided with a pair of pewter jug-shaped flagons in the reign of **Elizabeth**, similar to those of silver found elsewhere; but none of that date are now to be met with. We have just one specimen, at Lubenham (*Plate IX.*), of the many pewter flagons that were evidently bought early in the 17th century in accordance with the 20th canon of 1604, which orders that the wine be "brought to the communion table in a clean and sweet-standing pot or stoop of pewter, if not of purer metal." The Bishop put that canon in force: for we find the churchwardens of St. Martin's, Leicester, being presented in 1611-12 for not having a flagon (p. 89). At Kimcote a pewter flagon was bought in 1608 for 8s. 2d. (p. 366); and at Loughborough "two great pewter flagons" are named as belonging to the church in 1620 (p. 45). The Lubenham flagon, made in 1635, may be taken to be a specimen of many made of pewter early in that

Pewter flagons largely bought after 1604

* *Cardwell's Documentary Annals*, Vol. i., p. 151. † *English Church Furniture*. Edward Peacock, F.S.A.

century; others were doubtless tankard-shaped: of these latter we have now none of earlier date than the one at Hose (*Plate IX.*), made not later than 1670; after which we meet with many made in that century and the next. The great majority of these pewter tankards were made for church use. Other pewter vessels of interest are the patens made in the middle of the 17th century, similar to the one at East Norton (p. 252). These are perfectly flat plates with wide edges, a small portion in the centre being slightly sunk; the pewter paten being in fact of the same shape as the one of silver found occasionally at that date (p. 228). Later in that century, and early in the next, are found fairly often pewter salvers on feet, shaped like those of silver, and made specially to serve the purpose of patens; some of which have gadrooned edges (*Plate IX.*, and p. 389). Chalice of pewter are now very uncommon since those few that once existed have been gradually superseded by vessels of silver. We still have however two in the twin pewter services of Cranoe and Stonton Wyville (*Plate IX.*); and the latter service is still completed with the large pewter alms dish, than which many a worse looking piece has been purchased in modern times; there is another to be seen at Melton (p. 164): and one at Brooksby (p. 286). We find the churchwardens of St. Martin's, Leicester, buying, in 1638, "a dish for the offerings;" but that and most other churches had been provided with such a dish long before that date, for the rubric in the Prayer Book in use from 1559 ordered the churchwardens to "gather the devotion of the people and put the same into the poor men's box:" our present rubric dates from 1661.* It is worth mentioning that amongst the articles named by **George Herbert** as those that should be found in every church are, "a chalice and cover, and a stoop or flagon, and a basin for the alms and offerings."† In spite of each of our churches having been provided with such a basin we do not now seem to have in this county any older than the one at Melton, which could not have been made before 1675, and those of that date are extremely rare. We meet more often with the small alms basin of the first-half of the 18th century, some of which were procured for use in the font. In addition to these pieces we have a large number of pewter trencher plates, many of which were once of secular use and have been procured from time to time for collecting plates; now and then one has been used as a paten: these date from 1675 downwards. We have three pieces of pewter, all probably once of secular use, that are worthy of special notice: the engraved tankard at Waltham-le-Wolds (*Plate XXIII.*); the covered porringer, made in imitation of one of silver, at Frowlesworth (*Plate XXXII.*); and the basin, once also a porringer perhaps, at Claybrooke (*Plate XXVIII.*)

In proportion to the large number of pewter vessels bought for our churches

*Pewter patens
of 17th and
18th centuries.*

*Chalices of
pewter never
very common.*

*Pewter alms
dishes.*

*Pewter trencher
plates,
numerous.*

*Secular pieces
of pewter.*

* *Hist. of the Prayer Book.* F. Proctor., 11th Ed., p. 350.

† *The Works of G. Herbert.* G. Routledge, p. 246.

within the last three-hundred years, not as many are now to be found as might be expected. Their comparative scarcity is owing a good deal to the small cost of the material, which has caused pewter vessels to be often despised, badly taken care of, and readily parted with when vessels of silver have been acquired. Those that are left are worthy of being better cared for; and even in that church which is well provided with a silver service good use may be found for the more humble vessels of pewter.

Even without the help of churchwardens' accounts the canon and rubrics referred to above shew that much of the pewter was bought by the parishioners. Bishops at their visitations have from time to time taken care that each church should be provided with vessels actually necessary for divine worship; and, while not enforcing the purchase of anything costly, have ordered at any rate pewter to be bought by the parishioners when needed. But all was not by any means so bought; individual liberality has often come to the fore in spite of parochial obligations; and several such gifts have been recorded in these pages: **John Bailey** gave a pewter flagon to Wigston church in 1594 (p. 333); while Shawell still has some pewters given in 1685 by the rector (p. 352); and Shenton some given early in the last century by Mrs. **Beeby** (p. 419). Neither are bequests of money for the purchase of pewter communion vessels altogether unknown; one such is met with at Gaddesby, where there are still a paten and tankard bought in 1682, with the legacy of **Dorothy Nedham** (p. 261).

Pewter vessels mostly provided by the parishioners.

Sometimes the gift of individuals.

Possibility of Dating Pewter Vessels.

The chronological summary of pewter vessels in this county, given in (*Appendix G*, p. 505), has been only very roughly put together; for exactness in dating pewter is at present impossible. Many more pieces have first to be examined and tabulated; their makers' marks illustrated; and the information locked up within the books at Pewterers' Hall made accessible. Meanwhile, an approximate date can be given to most pewter vessels. Not unfrequently a date is found to be actually a part of the maker's mark, which gives a *terminus a quo*; the piece must at any rate have been made within twenty years or so after the year named in the mark. Of course a maker often carried on business for many years, using throughout the same mark (*e. g.*)—**Jonas Durand** and his partner, **R. Sonnant**, adopted in 1699 a certain mark and placed that date within it; nearly thirty years after, two complete services were given to two churches in this county made by them probably at the time for that special purpose (pp. 179 and 194).

Pewter pieces dated with the help of makers' marks.

A *terminus ad quem* is gained occasionally with the help of a date engraved in an inscription: and since most of our patens, alms basins, and flagons of

With the help of inscriptions.

pewter were made for church use, a date in an inscription on any of those vessels is as trustworthy a guide as one in a maker's mark. Trencher plates may sometimes be inscribed with a date much later than that of their manufacture: an instance of that variance, shewn on another piece, is found in the flagon at Dalby Magna, the date in the maker's mark being "1671," and that in the inscription "1734" (p. 289).

Pewter pieces dated with the help of their shape.

The shape of a pewter piece is an obvious guide to its date, for pewterers adopted the designs of Silversmiths. The flat pewter patens of the 17th, and salver patens of the 18th century, shaped like those of silver, have been already noticed. Three or four little varieties in the shape of silver tankards help to date those made of pewter; a lid shaped like a befeater's hat, or a foot wide and curved (*Plate XXXIII.*), is a sure mark of the latter half of the 17th century; and the same date is traced sometimes in the very slightly projecting foot, conical drum and flat lid of a pewter flagon, like that at Witherley (*Plate XXXII.*): ovolo mouldings round the lid and foot usually mark a rather later date.

With the help of Terriers.

A little help may be gained in dating pewter vessels by noting any mention made of them in terriers; but those documents give such scanty descriptions of pewter that there is often some doubt whether the piece named is the same as that now in existence.

With the help of copper sheets at Pewterers' Hall.

Help of a more reliable kind is to be had from the copper sheets and freemen's books belonging to the Pewterers' Co.: when the former have been given in facsimile and the latter put into print, much information about pewterers and their work will have been made available. The sheets (five in number) are stamped with the marks of different pewterers, probably all freemen of the Co. Each pewterer seems to have placed on the sheet his mark at the time he adopted it, so that on the whole the marks have been stamped in chronological order; now and then one is seen to have been put on out of its proper place. Those on the first sheet, judging from the dates in some of them, commence in about 1655 and end in about 1680; on the second sheet the first marks were stamped in about 1680 and the last in about 1705; those on the third date from about 1705 to 1735; and those on the fourth from about 1735 to 1790: the fifth plate contains only three rows of marks, and at its top is cut the date "1796;" it may therefore be concluded that soon after 1800 the practice of each maker stamping his new mark on a copper sheet at Pewterers' Hall ceased.

With the help of freemen's books.

If a pewterer was a freeman of the Co. and placed his name upon his mark, a clue to the date of his work can be gained by consulting the freemen's books, which begin in 1698, and give the date on which each apprentice took his freedom up.

Local Silversmiths.

All that can be said with certainty under this heading is that there have been in the town of Leicester, for more than three hundred years, a succession of silversmiths; whether any of them made any pieces of our church plate is at present a matter of conjecture. We first come across **Thomas Goldsmith**, in this entry of the Chamberlains' Accounts of that town:

No proof at present of any church plate having been made by Leicester silversmiths.

"1541. Itm̄ paed to **Thomas Goldsmyth** ffor mendyng of the
Towne Waytes Collars ijs. iiijd."*

Another member of the same family, **Robert Goldsmith**, was in the same trade and frequently figures in the accounts of the churchwardens of St. Martin's, Leicester; e.g.:

"1554-5. Itm̄ pd to **Robert goldsmyth** for a pattyn of a challyce xjs. iiijd."†

The next name of a Leicester silversmith appears in this entry in the Chamberlains' Accounts:

"1576. Itm̄ paid to **Dodd**, the Goldsmith, for xv. ounces of silver for the Weytes collars and for mendinge or makinge of them new vli. xs."

This entry rather reads as if **Dodd** had remade the waites collars in his own workshop. If he was himself a working silversmith it is just possible that the numerous chalices stamped with the "rose" were his work (p. xii. *ante*).

In the registers of St. Martin's, Leicester, are numerous entries relating to a family named **Dodd** or **Dod**, which are here given, with this caution; there is no proof that **Thomas Dodd** was **Dodd** the goldsmith.

1580.	Oct. 16.	John , son of Thomas Dod , baptized.			
1581.	July 8.	Thomas	"	"	"
1584.	April 5.	William	"	"	"
1586.	July 3.	Mary , daughter of Thomas Dodd , baptized.			
1588.	Aug. 10.	Wynefrede	"	Dod	"
1589.	Dec. 20.	Catherine	"	"	"
1600.	Aug. 31.	Alice	"	"	"
1602.	Nov. 14.	Moses , son of	"	"	"
1610.	April 1.	Thomas	"	"	"
1618-19.	Jan. 14.	Mary , daughter of	"	"	"
1582-3.	Jan. 13.	Thomas , son of	"	Dodd	"
1583-4.	Feb. 23.	William	"	"	"

In the registers of St. Mary's, Leicester, is this entry:

"**Thomas Dodd** and **Sara Parker** married Feb. 19, 1617."

* For this and many interesting extracts from the Corporation Muniments see *Notices of Leicester*, by W. Kelly, F.S.A.: J. Russell Smith, 1865. † *Ibid* page 88.

In the middle of the 17th century **John Turville** was the principal silversmith in Leicester. He was employed by the Corporation to supply them in 1650 with a new mace and to put the royal arms upon it at the Restoration.* **J. Turville** also supplied four smaller silver maces and various other articles from time to time, as mentioned in the Chamberlains' accounts. In 1663 a communion cup was bought from him for St. Mary's, Leicester (page 96), and probably similar purchases were made through him for other churches. But there is nothing to show him to have been a working silversmith: on the contrary, as far as we have been told, he seems to have been simply the middle-man through whom goods were procured from London. The great mace was made by **Thomas Maundy**, goldsmith, of London, in accordance with an order in parliament dated 6th June, 1649, giving him the monopoly of the manufacture of every mace in the country.† The mace of 1650 stamped with his mark an *interlaced M*, very like that mentioned by Mr. **Cripps**, under the year 1665,‡ replaced one made as late as 1645 immediately after the theft of the old one by the Royalist army; this speedy replacement was perhaps partly due to the monopoly given to **T. Maundy** as well as to the wish of the Corporation to possess a more valuable mace than the one bought in 1645. **John Turville** was churchwarden of St. Martin's, Leicester, in 1657, and there are several entries relating to his family in the registers of that parish, two of which are as follows:

" 1638-9. Jan. 2, **Susanna**, wife of **John Turvill**, goldsmith, buried."

" 1653. Feb. 20, **John**, son of **John Turvile**, goldsmith, by **Ellen**, his wife, was borne."

After **J. Turville**, a certain Mr. **Lee** seems to have been the chief silversmith in Leicester. We find this entry in the Chamberlains' accounts for 1695:

" Itm paid to Mr. **Lee** for new makeing the Waits Badges, and one
of the Sergeants Mace and a Chamberlaines staff 6 15 0"

He, like his predecessor, was simply a retailer: one of the badges § here named is now in the Leicester Museum, and is stamped with the London hall marks for 1695, the maker's mark being *I. H.*, a star between two pellets above, in a shaped shield.

Local Pewterers.

As of the local silversmiths, so of the pewterers it can only be said with certainty that various people are found to have carried on that trade in

* The same mace now in the possession of the Borough, recovered in 1866. Vide *The Great Mace*. W. Kelly, 1875. † *Hist. MSS. Commission, Report* viii., page 437. ‡ *Old English Plate*, 3rd Ed., page 325. § For an illustration of which see *Royal Progresses to Leicester*, by W. Kelly, F.S.A., p. 551.

Leicester: but there is no proof of any of them having actually made any of the pewter vessels now existing. Possibly some of the flagons and other pieces not marked at all, or not stamped with the mark of a London maker, may be of local make. Most of our vessels have however apparently been made in London and retailed by the local pewterers, some of whom may have added their initials, or other marks, to those already stamped upon the piece. It will be noticed in *Appendix G* that certain London pewterers have at different times been rather largely employed by our local retailers; one of these, **Thomas Hodgkin** (p. 519), was probably of Leicester origin, for it seems likely that he was the same individual as the one named in this marriage bond.*

"**Thomas Hodgkin**, of St. Martin's, Leicester, pewterer, aged 23, Bachelor, & **Ann Bennett**, of the same, aged 30, Spinster, 19th Dec., 1748."

Their marriage is thus recorded in St. Martin's registers:

"**Thomas Hodskin & Ann Bennett**, both of this parish, married 22nd Dec., 1748."

Former Inventories.

In making this catalogue of church plate the following inventories have been consulted: first, those included in the terriers. Since Leicestershire formed until 1839, a portion of the diocese of Lincoln, it is in the registry of that See that terriers for this county are found, such, at least, as were delivered to the Bishop; those made for the Archdeacon are in the custody of the registrars at Leicester. We owe to Bishop **Wake** the introduction of a list of church plate into terriers, which, before his day, contained no such entry (*Appendix C*, p. 451). Dr. **William Wake**, Dean of Exeter, was consecrated Bishop of Lincoln on 21st Oct., 1705, and translated to Canterbury in 1715; on 20th April, 1706, he issued monitions for his primary visitation, containing, with other matters,

*Church plate
recorded in
terriers*

"Heads to be observed or directions for the Ministers and churchwardens in forming and drawing up their terrars for the better preserving the rights of the Church; " of which this was Article VI.:

"Furniture in the church or chancel, the utensils, bells, clock, books, surplices, with the weight of the communion plate and the inscriptions thereon."

That order relating to the making of terriers concludes with:

"Note also the terrar must be all written in a fair and legible hand with good and durable ink upon a distinct and handsome piece of parchment and not upon paper." †

* For extracts from Leicestershire marriage bonds see *Transac. of Leicest. Archite. Soc.*, Vol. vii., p. 168.

† Many terriers were made in 1605, in obedience doubtless to the 87th canon of the previous year; some of the earlier ones are beautifully written on thin strong paper in book form.

The Bishop, in issuing monitions for his second visitation, held in 1709, ordered all clergy to produce terriers unless exhibited since his primary visitation: the same order was repeated in the monitions for the visitation held in 1712.* The result of this care for "the rights of the church" on the part of the Bishop was the production, generally at his second visitation, of a terrier drawn up according to his ordered headings and inscribed on a large square sheet of parchment. Sooner or later every parish doubtless produced during the Bishop's rule its terrier in the prescribed form; but neither those of that or of any other date have been universally preserved. A record of church plate is occasionally found in later terriers. The terriers in the Archdeacon's registry at Leicester date mostly from 1638 downwards; not one of several dozen examined contains any notice of church plate.

*Inventories
sent in to
Archdeacon
Bickham.*

In that registry are a set of inventories of church plate, in a certain number of parishes, drawn up for Archdeacon **Bickham** between 1775 and 1780 (*Appendix D*, p. 459).† We may conclude that one from each parish in the county was sent in to the Archdeacon, by his order, sometime within those years, and that very many have been lost. An entry in the Tugby parish register (p. 250) confirms this conclusion, for in it has been entered what was evidently a copy of the return sent to the Archdeacon in 1777, the original of which is not now to be found with the rest. These inventories record the church plate only.

*Inventories of
Archdeacon
Bonney.*

To one of **James Bickham's** successors, Leicestershire is indebted for a perfect inventory of church goods. The Ven. **T. K. Bonney**,‡ made in 1832, shortly after his appointment, a thorough visitation of his Archdeaconry, and afterwards wrote an account of it, in his own neat writing, in six folio vols., one for each Hundred; the deanery of Christianity being included in the Akeley volume. The Archdeacon gives precise information respecting the state of the church in each parish under these headings: *Population; Patron; Rector; Services; Fabric; Furniture; Books; Vestments; Vessels; Benefactions; Churchyard; Minister; Parochial Library; Parish Clerk; Schools; General observations*. This valuable record is now in the Leicester Free Library, where there are also four other folio MS. volumes giving an account of the Archdeacon's visitations in 1835-6 and 1842: the two volumes recording the former contain notes of repairs, &c., recently made in each church, and of others ordered to be carried out: in the other two a record of the visitation of 1842 has been entered on much the same plan as that adopted ten years earlier, but in not quite such an elaborate manner. The many references made to it in these pages show the use that the Archdeacon's account of his

* Bishop Wake's register. † The Archdeacon was rector of Loughborough, and died 23rd Dec., 1785.
‡ Rector of Normanton, co. Rutland, where he lived, and of Coningsby, co. Lincoln, ob. 7th April, 1863.

first visitation has been to the compiler of this *Inventary*; the church plate mentioned in it will be found in (*Appendix E*, p. 463).

Our great historian of Leicestershire occasionally mentions the amount of communion plate belonging to a parish. In his *Additional Collections towards the History and Antiquities of the Town and County of Leicester*, published as the fifty-first number of *Bibliotheca Topographica Britannica*, Mr. **Nichols** printed no less than 74 questions addressed to the "Nobility, Gentry and Clergy" of the county, with the view to gathering information relating to the history of their several parishes, the 15th was as follows: "Are the font, altar-piece, or plate, ancient, or any way remarkable?" Judging from the rare mention that he makes of church plate, the information that he received under that head must have been but little.*

Church plate mentioned occasionally in Nichols' Hist. of Leicestershire.

Identification of Donors.

The least doubt that may exist about the identification of any donor has been laid bare in this *Inventary*; no name and gift have been definitely coupled together except when that union can be effected with certainty. Of course the name of a donor is learnt in the easiest way when an inscription has been engraved upon the gift; and such a record is found to have been very usual from the time that gifts of plate were once again offered to the service of God early in the 17th century. But even in an inscription the donor is not always specified with certainty. There may very well be more than one **John Wilkins** living at the same time (p. 93) and more than one **Elizabeth Coates** (p. 90), and even when the silver dish at Shackerstone (p. 392) is said to have been given by "**Ann**, the wife of **William Gibbs**," the truth could not have been learnt from the inscription alone. Still greater difficulty in identifying a donor, even with the help of an inscription, is to be met with when the gift itself no longer exists, as at Loughborough, where was once a silver cup and cover inscribed "Ex dono **Barthol. Hickling**," and another inscribed "Ex dono **Johannis Oldershaw**" (p. 45).

Donors identified through inscriptions.

A donor has not unusually engraved his name on his gift in a coat of arms, in addition to and sometimes in lieu of an inscription; in the latter case especially heraldry is obviously of great assistance in the identification of a donor. In the arms of **De la Fontaine** on the silver dish at Kirby Bellars (p. 161), in the crest of **Levinge** on the Sheepy service (p. 393), in the beautifully engraved quarterings of Lord **Wentworth** on the plate belonging to Kirkby Mallory church (p. 411), and in many other heraldic

Through coats of arms.

* For a list of these questions see Nichols' *Hist. of Leicest.*, Vol. iii. p. xii.

inscriptions the name of the donor has been as plainly recorded as if it had been engraved in words. A piece of communion plate is often all that remains in a parish to mark the connection that once existed between it and some ancient family for long years. Estates have changed hands, families have become extinct; there is just the little piece of heraldry on a gift of plate that keeps alive in the place the donor's name: there has been too much destructive restoration in recent years, for

"A herald, who that way doth passe,"
to "Finde his crakt name at length in the church-glasse,"

but he may still find it written out on the vessels of the altar. And that little bit of heraldry has not only served to keep the name of some well known family alive in its former dwelling place,—it has more than once, in this county, at any rate, been the means of bringing to light the existence of such a connection, in cases hitherto but little known. Lord **Wimbleton's** crest on his gift to Lowesby (p. 273) is a memorial of the short lived union that once existed between the family of **Cecil** and that place; and through the arms of Sir **William Jones** on his gift to Welby (p. 173, *Plate XI.*) has been traced a bond once formed between a family of Shrewsbury and that little Leicestershire parish. At Peatling Parva is a silver paten bearing the arms of **Falkener** (p. 371), showing a hitherto unsuspected connection which it has not been possible to define: and at Somerby (p. 177) has been found a coat of arms, the correct interpretation of which would probably add a new fact to the history of the parish. Besides naming a donor, a coat of arms on church plate is often of the same genealogical use as when found elsewhere, especially when the arms of a husband and wife are impaled, as at Scaford (p. 175, *Plate VII.*), or when many quarterings are given, as on the flagons at Market Bosworth (p. 415).

Since it has been the custom for centuries, except when the plunderer has been abroad, for churchmen to make bequests to their parish church, a search amongst wills helps to identify many a donor of church plate. Occasionally a totally unsuspected gift of plate may, by some happy chance, be found recorded in a will; such as the bequest of a silver flagon once belonging to St. Margaret's, Leicester (p. 83), the chalice still in Scraftoft church (p. 219), and a pewter piece once at Lutterworth (p. 347). But where wills have proved of the most service in this *Inventory* is in the identification of doubtful donors: many a little difficulty has been cleared up and many a gift assigned to the right donor by a clause contained in a will. Without that help there would have been some uncertainty in recording such a gift as that made by Mrs. **Dean** to St. Nicholas', Leicester, eight years after her death (p. 103), and some doubt in naming the donor of a silver paten to Desford

bearing an inscription dated four years before the piece was made (p. 316). In giving information in this work relating to a donor's possessions, dwelling place, relatives and date of death, wills have proved an invaluable help. *

Parish registers and churchwardens' accounts should always be consulted for any information that they may by chance contain respecting the origin of the altar vessels. In the former is to be found such an entry as that in the register at Burton Overy recording full particulars of **John Weston's** gift, which certainly could not have been learnt from any other source (p. 200): similar information is given in the registers of Alexton (p. 228), Owston (p. 276), and Wymeswold (p. 307). And churchwardens' accounts are equally useful for the same purpose, for they not only contain entries recording the exchange or purchase by parishioners in a body of church plate, but in them may often also be found some entry giving a clue to a gift made by an individual. The first intimation of a gift once made to Loughborough by Mrs. **Davenport** is met with in the church accounts (p. 45): in the accounts of St. Martin's, Leicester, are several entries recording gifts of plate (p. 89) and a precise statement of **Elizabeth Walker's** gift has been entered in the accounts of Market Harborough (p. 192). For their negative evidence churchwardens' accounts are of value, for if in them can be found no entry recording the purchase by the parishioners of an unscribed piece, there is every reason for concluding it to have been the gift of an individual. They are worth searching also for genealogical purposes, but of course do not yield the same return in that respect as parish registers, many of which have been largely consulted in compiling the short biographical notices of the donors in this work. †

Donors identified through parish registers and accounts.

Though **Nichols**, in his history of the county, was not able to describe the communion plate belonging to every church (p. xxvii. *ante*), he has occasionally included a list of sacred vessels in his account of a parish; and in doing so has more than once named the donor of some unscribed piece, who otherwise would probably not have been identified. Unless he had recorded the fact, while it was well known, there could not have been the same certainty in ascribing the gift of the valuable service at Swithland to Sir **John Danvers** (p. 62): neither should we have known without his note, copied from one made by **Peck**, that the little paten at Goadby was the gift of **Elizabeth Carter** (p. 136); and the modest donor of the flagon to Appleby church would have remained anonymous had not **Nichols** learnt his name and recorded it (p. 375).

Through Nichols' Hist. of Leicestershire.

* During a very lengthy search unvarying kindness has been shewn me by **J. Challenor Smith, Esq.**, of the Probate Registry, Somerset House, and Messrs. **G. H. and T. Nevinson**, of the Probate Registry, Leicester.

† Wherever a parish register is quoted an exact transcript of the entry referred to has always been made, though not given in the reference.

*Donors
identified
through
Archdeacon
Bonney's
inventory.*

Archdeacon **Bonney** now and then entered the name of a donor in his inventories before it slipped out of men's minds; so that those carefully-written folios of his are of a little use in the identification of an occasional donor as well as of great value as a record of the amount of plate. Without his help it would only have been a probable guess to have said that Sir **G. H. Beaumont** gave the modern service to Cole Orton church (p. 18), and under Humberstone we find him speaking of a gift of a silver cup made by Miss **M. Frewen**, now alas no longer there (p. 264).

*Through
inquiries
made recently.*

It has been more the custom recently than at any former time to place an inscription on a gift of church plate, so that there has not been much difficulty in identifying the donors of most modern pieces. But in a few cases it has not been always easy to discover the donor of an uninscribed gift made some thirty or forty years ago; for the name of a benefactor is quickly forgotten, unless a note of the gift has been made in a parish book. A careful inquiry has been made from all sources of information about the origin of every uninscribed modern piece of plate with results that would perhaps have been difficult to arrive at after the lapse of further years.



"And here we do give unto Thee most high praise,
and hearty thanks, for the wonderful grace and virtue
declared in all Thy Saints which are departed
hence from us with the sign of faith, and now do rest in
the sleep of peace: grant unto them, we beseech Thee,
Thy mercy and everlasting peace."

First Prayer Book of Edw. VI.

ADDITIONS AND CORRECTIONS.

ADDITIONS AND CORRECTIONS.

- P. iii. Line 5. A transcript of the will of **Agnes Atkinson** may be seen in *Market Harborough Records*, (p. 218) by the Rev. **J. E. Stocks**, M.A.*
- P. 8. Line 26. For "Kippary" read "Kippax."
- P. 37. Line 10. **Elizabeth Roby** was born on 13th Jan., 1773.†
- P. 47. Line 34. For "**Barthlomew**" read "**Bartholomew**."
- P. 88. St. Martin's, Leicester, has also:

SIX PEWTER ALMS BASINS. Diam. of each $9\frac{1}{2}$ in.

Marks on each: 1. Out of a ducal coronet a horse's jamb, within an ornamental shape. 2. X crowned. 3. "London." 4. In four small shapes: (a) per chevron engrailed three griffins' heads erased; (b) on a fess three escalops; (c) griffin's head erased on a wreath; (d) J.I. On the edge of each of these plain basins is: "*St. Martin's, Leicester, Wm. Sultzzer, Jno. Riley, churchwardens, 1810.*"

TWO PEWTER ALMS BASINS. Diam. of each $9\frac{1}{2}$ in.

Marks on each: 1. Out of a ducal coronet a horse's jamb. 2. X crowned. 3. "London." 4. In four small shapes: (a) "Y.R. & S.;" (b) Two arms embowed holding a dish; (c) On a fess three marks; (d) some head erased. On the edge of each is: "*St. Martin's, May 18th, 1845, Leicester, C. B. Bowmar and I. W. Rose, Churchwardens.*"

- P. 92. (f) The two missing vols. of churchwardens' accounts for St. Martin's, dating from 1782 to 1851, have just been recovered. In the first is this entry:
- "1784. April 17. P^d for a Silver Communion Dish... £19 10s. 6d."
- P. 94. Church of the Martyrs, Leicester. The communion plate belonging to this new church is as follows:

TWO SILVER CUPS. Weight of each 7 oz. Height $6\frac{3}{8}$ in. Diam. of bowl $3\frac{1}{2}$ in.; of foot $3\frac{3}{4}$ in. Height of stem $2\frac{3}{8}$ in. Date 1889.

London hall marks.

These are plain chalices made out of hammered silver, and fashioned after the shape of a 17th century cup; being very similar to the one at Kirby Bellars (PLATE VIII). Each has a nearly straight-sided bowl and a conical stem in which is a disk.

* Elliot Stock, 1890. † Vide *Pedigree of Roby of Castle Donington*, by Henry J. Roby, M.A., of Wood Hill, Pendleton. Privately printed; Manchester, 1889.

TWO SILVER PATENS with feet. Weight of each 10 oz. Diam. $7\frac{3}{8}$ in. Diam. of foot $3\frac{3}{8}$ in. Height of foot $1\frac{7}{8}$ in. Date 1889.

London hall marks.

These are plain flat patens each standing on a hollow foot.

SILVER FLAGON. Weight 25.5 oz. Height $8\frac{5}{8}$ in. Diam. at top $3\frac{1}{4}$ in. ; at foot $5\frac{1}{4}$ in. Date 1889.

London hall marks.

This is a plain tankard shaped flagon.

On each of these five pieces is; "*This do in remembrance of me.* LUKE xxii.

19. 1st Cor. xi. 24, 25;" and "*Church of the Martyrs, Leicester. Consecrated 1890.*"

This church, dedicated to the memory of the Marian Martyrs and consecrated on 17th July, 1890, has been built and endowed at the sole cost of the Rev. **Joseph Harris**, M.A., of Herm House, Eastbourne, the owner of the Westcotes estate, in the midst of which the church has been placed. The new streets recently built on that estate have been named after the leaders of the Reformation. The district assigned to the church is a portion of St. Mary's parish. The communion service has been given to the church by the founder's brother, Mr. **William Harris**, of Sykefield, Leicester.

P. 118. Line 14. For "**W. O. Norman**," read "**M. O. Norman**."

P. 123. Last line. The Rev. **G. S. Outram** is now incumbent of Ropsley, Lincolnshire.

P. 179. Bowden Magna. The silver paten was *not* bequeathed to this church by Mr. **Wotton**, in his will.

The Rev. **Richard Wotton** "of Little Bowden, clerk," in his will, made 4th April, 1758, and proved in the Court of the Archdeacon of Northampton on 14th Oct., 1758, left to sister, **Ann Woton**, her heirs and assigns, the advowson of the church of Little Bowden, and also all his messuages, closes, lands, and tenements whatsoever and wheresoever. To sister **Mary**, £150. To sister **Sarah**, £150. Brother-in-law Mr. **West**, his wife and five children mentioned. Brother-in-law **Isaac Bullock** and wife mentioned. To **John Holmes**, clerk of the parish of Little Bowden, £10. To poor of Great Bowden, £10. To poor of Little Bowden, £10. **Ann Wotton**, executrix and residuary legatee. Seal: a griffin segreant, in a lozenge.

PP. 204 & 218. Sir **Arthur Grey Hazlerigg's** long and honourable connection with the county of Leicester came to a close with his death on 10th May, 1890.

P. 221. Line 10. For "**Lucy Parker**," read "**Lucy Bradgate**."

P. 229. Alexton. It must be recorded here with much regret that the silver paten given to this church by Lord **Willoughby de Broke** is not now to be found. It was used for the last time by Mr. **Norris**

on Christmas Day, 1889, and there is reason for supposing it to have been stolen after his death. Let us hope that even yet it may, by some means, be restored.

P. 229. Lines 11 & 27. } For "Compton Mundac" read "Compton
P. 230. Line 5. } Murdac."

PP. 235 & 248. Lines 17 & 4. For "T. N. Fallow" read "T. M. Fallow."

P. 252. **Charles Parker** and **Catherine Wilson** were married on 1st March, 1711-12, at Gray's Inn Chapel.* He was elected M.P. for the city of Peterborough in 1710, *not* 1708, and represented that borough till 1722. Since the recent rebuilding of the tower of Peterborough Cathedral two blue marble slabs have appeared to view in the floor of the south aisle near the transept; one of which is thus inscribed: "*Here lieth the body of Charles Parker Esq. who departed this life Feb. ye 25 1730 aged 69. And also ye Body of Mary Parker who died Jan. ye 9 1682 aged 46.*" The inscription on the other is: "*Here lyeth the body of Samuel Parker gent who departed this life February the 22 1738 aged 38 years.*" This **Samuel** was a son of **Charles Parker**, by his first wife, and was baptized at St. John's, Peterborough, on 21st Nov., 1700.

P. 253. The Rev. **Thomas Norris** died at Alexton Rectory, on 18th Jan., 1890. He was the son of Mr. **Thomas Norris**, of Bottesford, in this county, and was born on 28th Oct., 1821. Graduating from Trinity College, Dublin, he was ordained deacon in 1851, and spent the whole of his useful clerical life within the three neighbouring parishes of Tugby, East Norton and Alexton. Mr. **Norris** married, on 30th June, 1857, at Handsworth parish church, Staffs., **Mary Elizabeth**, daughter of Mr. **Samuel Hammond Turner**, of Heath Green, in that county, by which lady, who survives him, he had several children.

P. 274. Line 27. For "Court" read "Count."

P. 280. Line 24. For "R.D." read "K.D."

P. 307. Wymeswold. The inscription, "*Soli deo honor et gloria*," was more likely placed on this cup *not after*, but *at the time* of its manufacture. The same words were on two silver censers belonging to Lincoln Cathedral in 1548.† At Corpus Christi College, Oxford, is a cup, made in 1515-16, very similar to this in shape, but more ornamental and fitted with a cover.

* *Gray's Inn Register*, by Joseph Foster, p. lxxvi. † Inventory printed by J. Simpson, in *Old Lincolnshire*, Stamford, 1883, p. 52.

- P. 368. Line 5. For "anno" read "arm^t."
- P. 369. Line 30. For "**Maria Pulteney**" read "**Maria Eure.**"
- P. 371. Peatling Parva. The maiden name of **Mary**, wife of **Lion Falkener**, was *not* **Falkener**. She was the third daughter of **Robert Barton**, of Brigstock, co. Northampton, gent., and married **Lion Falkener**, at Barton Seagrave, on 13th Oct., 1706.*
- P. 428. **T. Hearne** was too hasty in recording the death of Sir **Basil Firebrace**, for that event did not take place until 10th May, 1724. (*Mawson's Obits.*).†

* *Vide* Pedigree of Barton in *Miscell. Genial. & Herald*, 2nd series, Vol. iii., p. 177.

† *The Genealogist*, New Series, Vol. vi., p. 103.



THE CHURCH PLATE

OF

LEICESTERSHIRE.

AKELEY WEST DEANERY.

ASHBY-DE-LA-ZOUCH.	ST. HELEN.	PACKINGTON.
„	HOLY TRINITY.	SNIBSTON.
BELTON.		NETHER SEALE.
BLACKFORDBY.		OVER SEALE.
BREEDON.		SWEPSTON.
STAUNTON HAROLD.		SNARESTONE.
CASTLE DONINGTON.		WHITWICK. ST. JOHN THE BAPTIST.
COLE ORTON.		„ ST. GEORGE.
DISEWORTH.		„ ST. ANDREW.
LOCKINGTON.		WOODVILLE.
OSGATHORPE.		WORTHINGTON.

ASHBY-DE-LA-ZOUCH.

(a)

SILVER GILT CUP AND COVER PATEN. Weight of cup 20.2 oz. Height 9 in. Diam. of the bowl $4\frac{7}{8}$ in.; of the foot $4\frac{1}{2}$ in. Height of stem $4\frac{1}{2}$ in. Date 1562. (PLATE I.)

Hall marks. 1. Small black-letter E in a plain shield. 2. Lion passant. 3. Leopard's head crowned; each of the two last is within an outer line following the outline of the mark. 4. S R in a heart-shaped shield.

This cup similar in shape to many hereafter to be described is by far larger in size than any other cup of this date in the County, with the exception of one at Melton. Its bowl is shaped into an inverted truncated cone with sides a little convex and a lip very slightly bell-shaped: running round its lip is an engraved ornamental band $\frac{3}{8}$ of an inch wide, divided into six parts by curves of an hour-glass shape; this band is formed with two straps, ornamented with a zigzag line, enclosing foliage of the Elizabethan pattern, which foliage projects downwards out of the curve; every other projection being of a larger design than the other.

The stem of this cup is evenly balanced in shape, being divided in half by a knob, formed with a thin wide round moulding on a fillet; from whence the stem swells out to each end into a narrow vertical edge ornamented with little reeds. The foot, rounded off at the top, ends in a vertical and flat edge; reeds running round the former, an egg and tongue ornament round the latter.

SILVER GILT COVER PATEN with a foot. Weight 8.4 oz. Diam. 6 in. Diam. of the foot $2\frac{1}{2}$ in. Height of foot $\frac{3}{4}$ in. Date 1562. (PLATE 1.)

Hall marks the same as those on the cup.

This paten has a flat edge $\frac{3}{8}$ of an inch wide, round the inside of which is a rim ornamented with little reeds. The main part of the paten is sunk in a flat round shape. The foot is a disk, attached to another disk of the same size on the top of the paten by means of a straight round stem. This stem is plainly not the original one, which must have been slightly longer than this, and instead of being straight swelled out to each end. Round the top of the paten is an engraved band similar to the one round the bowl of the cup. A narrow moulding runs round the edge of the paten and also round the edge of its foot. Like most other Elizabethan cover patens, this one fits on the cup both as a cover and also with its foot downwards. Both it and the cup are made of very thick metal.

(b)

SILVER GILT CUP AND COVER. Weight of cup 31.2 oz. Height 10 in. Diam. of the bowl $5\frac{3}{8}$ in.: of the foot $6\frac{1}{2}$ in. Height of the stem $5\frac{3}{4}$ in. Date 1676. (FIG. 1.)

Hall marks. 1. Capital old English T in a plain shield. 2. Lion passant. 3. Leopard's head crowned; each of the two last being within an outer line shaped with the mark. 4. W W, a quatrefoil between two pellets below, in a shaped shield.

As far as Leicestershire is concerned this cup is unique; there are however others something like it. In giving an illustration of this one at page 176 of his book on Old English Plate,* Mr. Cripps says that it "resembles in general form an undated and not so highly ornamented cup used in Lambeth Palace Chapel. Somewhat similar ones dated 1637 are at St. Mary's, Lambeth." This very handsome cup has a straight-sided bowl, with a raised lip, rounded off below; the lower half being covered with repoussé ornament consisting of four winged cherubs' heads resting upon foliage in the renaissance style. The stem, which is octagonal in shape, is divided in half by a round knob upon which is engraved two shields one on either side, and between the shields, three lozenge-shaped ornaments. Upon one shield are these arms; *Argent, a Maunch Sable, Hastings; impaling; Sable, a chevron between three trefoils slipt, Or. Lewis*: an earl's coronet is above. The opposite shield is blank. At the lower part of the stem is an octagonal disk shaped into eight cusps; from whence the stem swells out into an octagonal foot each side of which is cusped. At each angle of the foot is a winged cherub's head. The repoussé work round the bowl is made out of a separate piece of metal; being in fact an outer perforated bowl into which the plain bowl fits. This outer ornamental bowl is held in its place by the stem being screwed on to the plain bowl.

SILVER GILT COVER. Weight 9.1 oz. Diam. $6\frac{1}{2}$ in. Date 1676. (FIG. 1.)
Hall marks the same as those on the cup.

* (John Murray) 3rd Edition quoted throughout.

This cover has a flat edge $\frac{3}{8}$ of an inch wide, from which the rest is sunk flat $\frac{1}{4}$ of an inch in depth. On the top of the cover is a repoussé ornament similar in style to that on the



Fig. 1. Date 1676. Rather more than half of full size. M. P. del.

cup; this being a quatrefoil upon a star of eight points between four winged cherubs' heads. From the centre of the quatrefoil rises a cross pance 2 inches high, having a boss in its

centre on each side. The Lion passant is stamped upon the cross. The repoussé work on this cover is also made out of an entirely separate piece of metal: it is held in its place on the top of the cover by the stem of the cross passing through it and being fastened by a nut on the inside of the cover. The total height of this cup and cover, from the foot of the cup to the top of the cross is 12 $\frac{3}{8}$ in.

(c)

SILVER DISH with a foot. Weight 40.1 oz. Diam. 1.4 in. Diam. of the foot 5 $\frac{1}{2}$ in. Height of foot 3 $\frac{3}{8}$ in. Date 1701.

Hall marks. 1. Court hand F. 2. Lion's head erased. 3. Britannia. 4. A and a small R, a quatrefoil above, in shaped stamp.

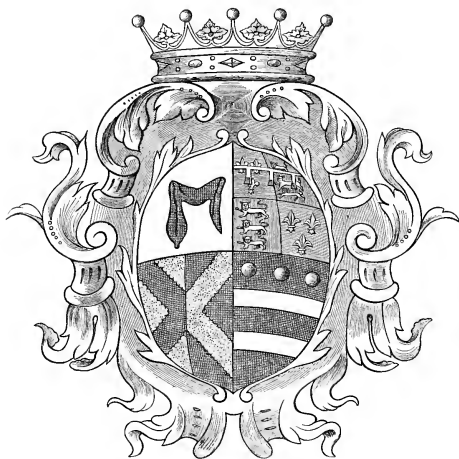

Fig. 2.

Dominus Theophilus Comes Huntingdon. Anno Domini MDCCI."

(d)

SILVER PATEN with a foot. Weight 10.3 oz. Diam. 7 $\frac{1}{2}$ in. Diam. of the foot 3 $\frac{3}{8}$ in. Height of the foot 2 $\frac{1}{4}$ in. Date 1703.

Hall marks. 1. Court hand H. 2. Lion's head erased. 3. Britannia. 4. D E, a cinquefoil below, in a shaped oblong; the Mark of Samuel Dell.

This paten is of the same shape as the dish. Underneath is engraved "M.D. 1646."

(e)

SILVER FLAGON. Weight 98 oz. Height 17 $\frac{1}{2}$ in. Diam. at the top 5 in.: at the foot 9 $\frac{3}{4}$ in. Date 1752.

This is a large flat dish with a raised edge. Its foot is a hollow drum swelling out into an ovolo moulding. In the centre of the dish is this coat of arms on an oval shield. *Quarterly.* 1. **Hastings**. 2. *Quarterly*; 1 and 4. **France (Modern)**; 2 and 3. **England**; a label of three points *Argent* each charged with a *canton Gules*. **Plantagenet** (Duke of Clarence). 3. *Per Pale Or and Sable*, a saltire engrailed counterchanged. **Pole**. 4. *Sable*, two bars *Argent*, in chief three plates. **Fitz-John**. Above, is an earl's coronet. (Fig. 2.) Below is this inscription; "*Ecclesie Ste Helene De Ashby De-la-Zouch DD Honoratissimus et prænobilis*

Hall marks. 1. Small Roman R in a shaped shield. 2. Lion passant in a shaped oblong. 3. Leopard's head crowned in a shaped shield. 4. T R G C, a pellet in the centre, within a quatrefoil; the mark of *Gurney and Co.*

This enormous flagon, the largest in the county, is straight-sided in shape, narrowing towards the top. It has a round top to its lid, mouldings running round its foot. In front is the sacred monogram with a cross and three nails within a circle of glory. Under the foot are the arms of **Hastings** within a lozenge, and this inscription; "*The gift of Lady Eliz: Hastings of Ledstone, by Lady Ann Hastings one of her Executors 1753 to the Parish Church of Ashby, Leicestershire.*"

(f)

SILVER ALMS DISH. Weight 40.1 oz. Diam. 14 in. Date 1755.

Hall marks. 1. Small Roman U in a shaped shield. 2. 3 and 4, as on the flagon.

This is a large plain basin-shaped dish, having in its centre a boss upon which is engraved the sacred monogram with a cross and three nails, within a circle of glory. Upon the back of the dish are the arms of **Hastings** within a lozenge; surrounded by this inscription; "*The Gift of Lady Ann Hastings by her Executrix and Niece Elizabeth Ann Wheeler 1755.*"

(a)

THE FIRST PIECE of communion plate described in this book is, as it so happens, the largest Elizabethan cup and cover in the county. Its unusual size is owing no doubt, not to the liberality of some member of the **Hastings** family as might at first be supposed, but to the fact that Ashby church possessed in the last year of **Edward VI.** two chalices of silver, which we may conclude were exchanged for this piece in 1562.

(b)

A table of benefactions placed in the belfry of this church records the gift of the second SILVER GILT CUP AND COVER in the following words:

"*The Right Honble. the Countess of Huntingdon gave Aug. ye 28th 1677 a Gilded Chalice and cover to this Church, weighing 41 ounces.*"

This lady was **Elizabeth**, eldest daughter and co-heir of Sir **John Lewis**, Bart., of Ledstone, co. York, by his wife **Sarah**, third daughter and co-heir of Sir **Thomas Foot**, Lord Mayor of London, and was born in London on 15th June, 1655. She was married in 1671 to **Theophilus**, 7th Earl of **Huntingdon**, and bore him **George**, his successor, two daughters, **Lucy** and **Elizabeth**, and other children who died young. The Countess died in London on 24th Dec., 1688, and was buried in the vault in Ashby Church on 12th Jan., 1689.* Her husband was the direct descendant of **William**, Lord **Hastings**, to whom the manor of Ashby was granted by **Edward IV.**, being the second but eldest surviving son of **Ferdinando**, 6th Earl of **Huntingdon**, by his wife **Lucy**, daughter and heir of Sir

* Parish Register.

John Davis, Knight, of Englefield, Berks., and was born at Donington Park, on 10th Dec., 1650. He inherited the title before he was six years old. During the last years of **Charles II**, **Theophilus**, Earl of **Huntingdon** was accused of being one of the supporters of the ambitious designs of the Duke of **Monmouth**: he however, finally left the Duke's party and made his peace with the King, who created him a privy councillor in 1683, and Lord Lieutenant of Leicestershire in the year following. From that time he was but too ready to assist the King in carrying out his despotic measures. In Oct., 1684, he negotiated with the Corporation of Leicester for the surrender of their charter to the King, and in order that he might the better control the future proceedings of the reorganised body he was made their recorder. He was equally ready to assist King **James II**. in similar measures; finally consenting to send a copy to the Corporation of Leicester of that sovereign's famous declaration.* These being the political opinions of this Earl, he was naturally one of those who were exempted from the benefit of King **William's** pardon; that king also deprived him of all his offices. He again suffered for his attachment to his old master, by being imprisoned in the Tower as a suspected person, together with the Earl of **Marlborough**, at the time when King **James** purposed making a descent upon England from La Hague in 1692. His last public service on behalf of his former sovereign was a protest against the Act of Settlement passed in 1700. The Earl of **Huntingdon** died in London on 30th May, 1701, and was buried under the South transept of Ashby Church; on the West wall of which is a monument to his memory bearing a long inscription in Latin.† The Earl married secondly, on 8th May, 1690, **Frances**, daughter and sole heir of **Francis Leveson Fowler**, Esq., of Harnage Grange, Shropshire, and widow of **Thomas**, 6th Viscount **Kilmorey**,‡ which lady was born at Kinderton, on 11th Aug., 1664. She bore the Earl of **Huntingdon** several children, and after his death married thirdly the Chevalier **Michael de Ligondes**, of Auvergne, in France. She died at Bath, on 24th Dec., 1723.

(c)

THE SILVER DISH with a foot was purchased in accordance with the following clause in the will of the above-named **Theophilus**, 7th Earl of **Huntingdon**, made on 18th April, 1698, and proved at Leicester on 17th Oct., 1702.

"I give to the said church of Ashby a patina or ciborium weighing full

* See *History of Leicester*, by James Thompson.

† For which see *Nichols*, Vol. iii., p. 621.

‡ *Publications of the Hist. Soc.*, Vol. x. p. 30.

40 oz. in silver to be used at the celebration of the most Holy Sacrament there for ever."

(d)

The identity of "M. D." the donor of the silver paten with a foot is revealed in the following clause of the above-mentioned table of benefactions; "*Mrs. Margaret Dent of this town, widow, gave a silver Bowl to this Church, since changed to a salver.*" This lady was the widow of **John Dent** of Ashby-de-la-Zouch, maltster, baptized here on 25th Aug., 1583, being the son of **Roger Dent** of this place.*

His will, made on 22nd July, 1645, was proved in Leicester on 2nd of Nov., 1646. He left £5 each to **Mary, Margaret, and Elizabeth**, daughters of **Nathaniel Bryan**, by his daughter **Mary** now dead: 10s. to the poor of Ashby. His wife **Margaret** he appointed residuary legatee and sole executrix.

The cup, changed in 1703 into this paten, no doubt was given by her to this church in memory of her husband, who died in the year in which the gift was made. Her initials and the original date of the gift were recorded, at the time of the transformation, upon the new piece.

(e and f)

The origin of the silver flagon and alms dish is more particularly described in the two following clauses of the will of Lady **Ann Hastings**, made on 21st Dec., 1751, and proved on 17th July, 1755, P.C.C.

"Also providing thereout,† in case I do it not in my life time, for the parish church of Ashby-de-la-Zouch in the county of Leicester a silver flagon of the same size with the pewter flagon they now use at the celebration of the sacrament; on the bottom whereof I desire" arms and inscription as given. "Also I will that my executrix provide a silver bason for the parish church of Ashby-de-la-Zouch in the county of Leicester not exceeding 40 oz. to be used in collecting the offerings at the celebration of the Holy Communion."

The flagon was therefore really the gift of Lady **Ann Hastings**, made during her life-time, in memory of her half-sister Lady **Elizabeth Hastings**, who had died some years before. Lady **Elizabeth** was the only surviving daughter of the above-named **Theophilus**, 7th Earl of **Huntingdon**, by his first wife **Elizabeth Lewis**, and was born on 19th April, 1682. This lady was a most charming character, being both clever and good. "She was above all a sincere Christian and a genuine daughter of the Church of England."‡ With truth it was inscribed on her coffin that she was "a pattern to succeeding ages of all that's good and all that's great." Upon the death of her

* Parish Register, in which is a gap in 1646.

† *I.e.* out of a sum of £400 left in trust to erect a monument to her sister at Ledstone.

‡ *Gen. Mag.*, Vol. x. p. 36.

brother **George**, 8th Earl, in 1705, she came into the large Yorkshire property which belonged to her mother, and consequently lived for the rest of her life at Ledstone. There she died unmarried on 22nd Dec., 1739, and was buried in the vault under that church.

In her will Lady **Elizabeth Hastings** left large sums to promote those good works in which during her life she had taken so much interest; such as these; an endowment to Queen's College Oxford; money to pay for the repair of different Churches, the building of vicarage houses, the increase of livings, the setting up of village schools in connection with the Church of England on or near to her Yorkshire estates. To the following churches she bequeathed communion plate; Thorp Arch, Collingham, Ferry-Fryston, Abberford, Thorne and Castleford co. York., Howe and Buckenham co. Norfolk.*

The actual donor of the monster flagon and alms dish, Lady **Ann Hastings**, was the eldest daughter of **Theophilus**, 7th Earl, by his second wife **Frances**, and was born in about 1690.

This lady, who lived at Ashby Place, inherited from her half-sister, Lady **Elizabeth** considerable property in Yorkshire.

Lady **Ann Hastings** died unmarried on 28th June, 1755, and was buried in the vault in Ashby church on 8th July:† to the record of her burial is added an obituary notice in which she is spoken of as one who was "firm in the ties of amity to her own family; friendly and benevolent to all mankind;" and as one who was "not forward to promise but ever punctual to perform."

The principal inheritor of her Yorkshire estates was her sister, Lady **Margaret**, wife of the Rev. **Benjamin Ingham**: her residuary legatee and sole executrix being her niece **Elizabeth**, the eldest daughter of the Rev. **Granville Wheler**, of Otterden Place, co. Kent, which lady afterwards married **Thomas Medhurst**, Esq., of Kippary Hall, co. York, from whom is descended **Charles Wheler**, Esq.,‡ of Ledstone Hall and Otterden. Lady **Ann** bequeathed also £35 to buy communion plate for West Leek church, co. Notts., in case she did not make the gift in her life-time. To the poor of Ashby she left £10, and to every widow or old maid who dined with her at Ashby on the Christmas day before her death 5s.

HOLY TRINITY. ASHBY-DE-LA-ZOUCH.

SILVER CUP. Weight 13.6 oz. Height $8\frac{7}{8}$ in. Diam. of the bowl $4\frac{1}{2}$ in.; of the foot $3\frac{3}{8}$ in. Height of stem $4\frac{3}{8}$ in. Date 1839.

London hall marks.

This cup has a straight-sided fluted bowl, bulging out below and swelling into a bell-shaped lip. It stands upon a baluster-shaped stem which swells out into a fluted octagonal foot. Upon the bowl is the sacred monogram with a cross and three nails within a circle of glory.

* See *Historical Character of Lady Elizabeth Hastings*, by Thomas Barnard, M.A.

† Parish Register.

‡ Whose father assumed that name.

SILVER CUP. Weight 13.1 oz. The same as the last.

SILVER PATEN with a foot. Weight 16.1 oz. Diam. $8\frac{3}{4}$ in. Diam. of the foot $4\frac{1}{4}$ in. Height of foot $2\frac{3}{8}$ in. Date 1839.

This is an octagonal-shaped paten with a moulding running round its edge. In the centre is the sacred monogram. It has a fluted octagonal-shaped foot. Under the paten is this inscription: "*This Service of Communion plate consisting of one Flagon two chalices one Patten and one Plate was presented to the Church of the Holy Trinity by the Ladies of Ashby-de-la-Zouch A.D. 1840.*"

SILVER PLATE. Weight 14.1 oz. Date 1839.

This plate is the same shape as the paten without its foot.

SILVER FLAGON. Weight 51.4 oz. Height $14\frac{3}{4}$ in. Diam. at the top $4\frac{1}{2}$ in.; at the foot $7\frac{3}{8}$ in. Date 1839.

This is a straight-sided fluted flagon, narrowing towards the top at which is a spout. It has a raised lid surmounted with a knob, an R shaped handle and an octagonal foot. In front is the sacred monogram with a cross and three nails within a circle of glory.

The ladies of Ashby presented this Communion Service to Holy Trinity Church on the day of its consecration by the Bishop of Peterborough, 13th Aug., 1840: the first stone having been laid by Earl Howe upon 25th Aug., 1838. The church was built at a cost of £4000 raised by subscriptions.

BELTON.

SILVER CUP. Weight 13.9 oz. Height $5\frac{3}{4}$ in. Diam. of bowl $3\frac{5}{8}$ in.; of foot $2\frac{7}{8}$ in. Height of stem $2\frac{3}{8}$ in. Date *circa* 1580.

Only one mark, a rose.

This cup, the first of the "rose" series to be noticed in this work, is similar to most of the others in shape. Its bowl is an inverted truncated cone placed originally into a projecting base; which has been covered over in recent years by a broad band of silver to prevent leakage, a disfigurement unfortunately to the cup. The stem is evenly balanced, divided in half by the usual flat moulding for a knob, and swelling out slightly at each end. The foot is also of the usual shape, being ornamented with vertical reeds, as are also the two ends of the stem. Round the bowl is an engraved band of stroke-ornament divided into six parts by hour-glass curves.

SILVER PATEN. Weight 3.6 oz. Diam. $5\frac{5}{8}$ in. Date 1879.

London hall marks.

This is a plain paten with a scroll ornament round the edge.

SILVER FLAGON. Weight 10.9 oz. Height 9 in. Date 1871.

London hall marks.

This is a plain jug-shaped flagon.

SILVER PLATED CUP. Height $7\frac{3}{4}$ in. Diam. of bowl 4 in.; of foot $3\frac{7}{8}$ in.

Mark "L Vickers, Britannia Place."

This is a plain-shaped cup with the sacred monogram in front.

SILVER PLATED FLAGON. Height $14\frac{3}{4}$ in. Diam. at top $4\frac{1}{2}$ in.; at foot $7\frac{1}{4}$ in.

No marks.

This flagon is of a huge size and very heavy, being in shape straight-sided narrowing to the top.

TWO SILVER PLATED DISHES. Diam $9\frac{1}{8}$ in.

Mark "G. Stacey, successor to L. Vickers, Britannia Place, Sheffield."

They have the sacred monogram in the centre.

In the terrier of this parish at Lincoln made in 1709, the church plate mentioned is; "a pewter flagon a pewter plate and a silver cup about 11 oz. weight." Either the weight of the cup was wrongly given, or else as is more probable, the cover paten then belonged to it.

The silver paten and flagon were presented to this church by Miss **Helen Blanche Middleton**, the daughter of the Rev. **J. E. Middleton**, the late esteemed Vicar of this parish, who died in Oct. 1885.

BLACKFORDBY.

SILVER CUP. Weight 5.4 oz. Height $5\frac{5}{8}$ in. Diam. of the bowl $3\frac{1}{2}$ in.; of the foot 3 in. Height of the stem $2\frac{3}{4}$ in. Date *circa* 1575. (PLATE I.)

No hall marks.

This cup has a bowl shaped into an inverted truncated cone with concave sides and a flat projecting base having a few lines running round its edge. Round the upper part of the bowl is an engraved band of Elizabethan foliage, divided into five parts by hour-glass shaped curves. The stem is evenly balanced, being divided in half by a knob formed with a small round moulding between two lines; from whence it swells out a little to each end into a narrow vertical edge. The foot is rounded off at the top into a narrow vertical and flat edge, a reed ornament running round the former. This cup has every appearance of having been made by the same maker as those which have been marked with a "rose" only. A few slight repairs were made in it about twenty years ago, at which time the "rose," if ever there had been one stamped upon it, may have been beaten out.

SILVER PLATED PATEN. Diam. $5\frac{3}{4}$ in.

This paten has a flat edge with an ornamental border. The middle is sunk flat so as to allow the paten to fit on the cup. In the centre is the Agnus Dei.

SILVER PLATED FLAGON. Height 12 in. Diam. at the top $2\frac{1}{4}$ in.; at the foot $4\frac{1}{2}$ in.

This is a jug-shaped flagon with an ornamental band round its middle, in front of which is a cross and on each side the sacred monogram.

PEWTER PLATE. Diam. 9 in.

Marks. 1. X crowned. 2. V & W in an oblong. This is a plain basin-shaped plate.

BREEDON.

SILVER CUP. Weight 5.8 oz. Height $6\frac{1}{2}$ in. Diam. of bowl and of foot $3\frac{3}{8}$ in. Height of stem 3 in. Date 1571. (PLATE 1.)

Hall Marks. 1. Small black-letter O in plain shield, the O having a small triangular mark below, probably caused by an error in the punch. 2. Lion passant. 3. Leopard's head crowned, each of these two marks having an outside line following their outline. 4. Illegible mark in plain shield.

The bowl of this cup is in shape an inverted truncated cone, very slightly concave, and has round it a band of Elizabethan foliage, divided into four parts by hour-glass curves. The stem which is divided in half by a round knob, has round its upper edge a band of reed ornament. The foot has been altered in modern times.

SILVER PLATED PATEN. Diam. 9 in.

SILVER PLATED FLAGON. Height $11\frac{1}{4}$ in. Diam. of top $4\frac{1}{2}$ in.; of foot $6\frac{1}{2}$ in.

This flagon is straight-sided in shape, narrowing towards the top, having a spout, and a round top to the lid.

PEWTER FLAGON. Height $13\frac{1}{4}$ in. Diam. at top $4\frac{1}{2}$ in.; at foot $5\frac{3}{8}$ in.

Mark on purchase, G I two pellets in a circle. This is a tall straight-sided flagon narrowing to the top, with a dome-shaped lid surmounted with a knob, a plain handle and thick purchase.

In 1832 the silver cup had a cover to it. A strict inquiry proves that this cover has not been seen or heard of during the last thirty years or more.

STAUNTON HAROLD.

The private chapel of Earl **Ferrers**, possesses a most interesting communion service, composed of the following pieces.

SILVER GILT CUP AND COVER. Weight of both 40.7 oz. Height of cup $10\frac{1}{4}$ in. Diam. of bowl $5\frac{1}{8}$ in.; of foot $7\frac{7}{8}$ in. Height of stem $6\frac{1}{4}$ in. Date 1640. (PLATE 2.)

Hall marks. 1. Court hand C in a plain shield. 2. Leopard's head crowned. 3. Lion passant; both within a shaped line. 4. RB, a star of six points below, within a heart-shaped shield.

This cup has a nearly straight-sided bowl rounded off into a flat base: on one side of it is engraved the figure of the Good Shepherd, on the other "*My blood is drinke indeed.* 1640."

The stem and foot are hexagonal and were evidently designed in imitation of mediæval work: the former is divided in half by a large round knob on which are six diamond bosses in low relief, an oval-shaped ornament between each. The foot ends in a vertical and flat edge: round each edge runs an oval ornament in relief: at each angle of the foot is a cherub's head winged.

SILVER GILT COVER with foot. Diam. $6\frac{1}{2}$ in. Height $5\frac{1}{2}$ in. Diam. of foot 3 in. Date 1640. (PLATE 2.)

The only hall mark is the same maker's mark as that on the cup. This cover has a flat edge, round the inside of which is a rim. The foot is a disk attached to the cover by a thick round stem swelling out at both ends; a narrow round moulding on a fillet runs round the middle of the stem. Upon the foot is fixed a tall Latin cross standing upon an orb. The sacred monogram within a circle of glory is engraved on the disk of the foot. Round the top of the cover is, "*My flesh is meat indeed.* 1640." This cover was evidently first made to serve as a paten, the cross and orb being an afterthought: without this addition the cover would fit on to the cup with the foot downwards.

SILVER GILT CUP AND COVER. Weight of both 47.7 oz. Date 1654.

The maker's mark only has been stamped on the cup, this being, on a wreath a greyhound sejant collared, a ring affixed to the collar at the back, within a shaped shield. This cup and cover are almost exactly like the first. There is no inscription on either. The knob on the stem of this cup is thinner than the one on the other.

SILVER GILT PATEN WITH A COVER. Weight of both 39.2 oz. Diam. of paten $6\frac{5}{8}$ in. Diam. of foot $6\frac{1}{2}$ in. Height of foot $2\frac{1}{2}$ in. Date 1654. (PLATE 2.)

Hall marks. 1. Court hand R in a plain shield. 2. Leopard's head crowned. 3. Lion passant; the two last being within a shaped outline. 4. On a wreath a greyhound sejant collared, a ring affixed to the back of the collar, within a shaped shield.

This is a basin-shaped paten standing upon an hexagonal foot which is much the same in shape as the feet of the cups. At the bottom of the paten inside is the sacred monogram within a circle of glory. Round the side is; "*The bread which wee breake is it not the communion of the bodie of Christ;*" and a cross fleury within a circle or glory.

SILVER GILT COVER. Diam. $7\frac{3}{8}$ in. Height $4\frac{1}{4}$ in. Date 1654. (PLATE 2.)

No hall marks.

This is similar in shape to the covers of the cups. Round the top of its foot is; "*My love is crucified.*" Round the top of the cover is; "*This is the bread which came down from heaven.*"

SILVER GILT PATEN WITH A COVER. Weight of both 38.7 oz. Date 1654.

The maker's mark only, the greyhound, has been stamped on this paten; which, with its cover, is exactly like the other one.

SILVER GILT FLAGON. Weight 44.1 oz. Height 10 in. Diam. at the top $4\frac{1}{8}$ in.; at the foot $6\frac{1}{8}$ in. Date 1654. (PLATE 2.)

The maker's mark, the greyhound, is the only hall mark. This is a straight-sided flagon narrowing towards the top. Its lid has a flat top rounded off into a wide flat edge. On each side of the purchase is a winged cherub's head. The handle is of the usual shape with a beaded ornament running down the back of it. On the top of the lid is; "*Holiness to the Lord*" within a circle of glory. In the front of the drum is "*The blood of the new and Eternal Testament*" and a crown of thorns.

SILVER GILT FLAGON. Weight 43.1 oz.

Exactly like the other one.

SILVER GILT ALMS DISH. Weight 111 oz. Diam. 20 in. Date 1654.
(PLATE 2.)

Hall marks as on first paten.

This dish is basin-shaped, rising up into a boss in the centre on which is the sacred monogram with a cross above and a heart below within a circle of glory; it has a flat edge $3\frac{1}{4}$ inches wide, round the rim of which is the egg ornament.

SILVER GILT CANDLESTICK. Weight 77.7 oz. Height to the sconce $18\frac{3}{4}$ in. Diam. of sconce $5\frac{3}{4}$ in. Diam. of foot $10\frac{1}{2}$ in. Date 1654. (PLATE 3.)

Hall marks as on first paten.

This candlestick has a thick baluster stem resting on a tripod-shaped foot ornamented with three heads of angels. Round the thicker part of the stem is a festoon of fruit in low relief, conventional ornament being chaste and engraved on the upper parts. The foot stands upon three escallop shells. There must have originally been a pricket to this candlestick. All that there is now is a wooden staff about two feet long made in imitation of a candle, which screws into the top of the candlestick. The top of this staff is hollow, so as to allow a short piece of real candle to be stuck into it. The junction of the real and sham candle is hid by a shield bearing the sacred monogram.

SILVER GILT CANDLESTICK. Weight 76.5 oz.

Exactly like the other one.

SILVER KNIFE WITH IVORY HANDLE. Parcel Gilt. Length 11 inches.
Date 1846.

London hall marks.

The handle is ornamented with engraved foliage gilt.

The older cup with its cover was plainly given to this church in 1640, its shape being copied fourteen years later in the second cup and the two covered patens, wrought by another maker; who seems also to have taken the first cup as his model when he made a service similar to this for the Duke of **Lenox** and **Richmond**, now belonging to Rochester Cathedral, stamped with the annual letter for 1653.*

This first silver gilt cup and cover must have been presented to this church by Sir **Charles Shirley**, Bart., the representative at that date of the illustrious family of **Shirley**.† Sir **Charles** was the eldest son of Sir **Henry**

* For description of which see *Church Plate of Kent*, p. 67, by Rev. Canon W. A. Scott Robertson

† For full particulars of which see *Stemmata Shirleiana*, 2nd Ed. 1873, by the late Evelyn Philip Shirley.

Shirley, 2nd Bart., by **Dorothy Devereux**, youngest daughter of the unfortunate Earl of **Essex**, and co-heir, in her issue, of her brother **Robert**, Earl of **Essex**, General of the Parliamentary Forces. Sir **Charles Shirley** was born on 9th Sept. 1623. He succeeded to the title, and to the estates at Staunton Harold and at Astwell co. Northants., on the death of his father on 8th Feb. 1632-3; and in 1641 he received back again the ancient family estates at Nether Ettington, co. Warwick, on the expiration of a one hundred years lease. He died unmarried, at Essex House, Strand, on 7th June, 1646, and was buried at Breedon on 3rd July.

All the remaining part of this communion service, with the exception of the knife, was given to Staunton Harold church by Sir **Robert Shirley**, Bart., the 2nd son of Sir **Henry**, who was born in 1629. This gentleman, on the death of his elder brother, succeeded to the family title and estates. Sir **Robert Shirley** was a devoted churchman and royalist. His devotion to the church one may well conclude originated from the teaching of his mother, who brought her sons up in her own faith and not in that of their father, who had died in communion with the church of Rome. In any case, during those days of trouble, none showed greater willingness to sacrifice everything for church and king than Sir **Robert Shirley**. At the death of his uncle the Earl of **Essex**, in 1646, Sir **Robert** became entitled to a share of that nobleman's property through his mother, who had died ten years before; a division of whose estates was finally made in 1653; Chartley, co. Staff., some houses in London, property in Newcastle under Lyne and elsewhere, falling to Sir **Robert's** share. Soon after this accession of wealth he began to rebuild Staunton Harold church, which was finally completed in 1663, in accordance with the instructions contained in his will proved on 11th June, 1657, P.C.C. Over the west entrance added to the tower are these arms over the inscription, *Paly of six Or and Azure, a quarter Ermine*; **Shirley**; *impaling, Ermine on a chief Gules three bezants*; **Okeover**.* This was not the kind of work to make Sir **Robert** popular with the powers that then were, especially since he aggravated the "offence" by making his house here a place of refuge for Church of England Divines who had been hunted out of their homes, and was moreover known at all times to be holding himself in readiness to support the royal cause. Such open devotion to church and king constantly brought down upon him the wrath of the Protector, who caused him to be imprisoned in the Tower on many different occasions. It was while he was undergoing his seventh imprisonment that Sir **Robert Shirley** died in the Tower, on 28th Nov. 1656. His body

* A careful examination would prove, I think, that the tower is a 15th century one, and was not rebuilt by Sir **Robert**.

was brought to Breedon and buried there on 22nd, Dec. ; but was afterwards re-interred in the vault under the chancel of Staunton Harold church, in 1661. Here, on the north wall of the chancel is a white marble monument to his memory, bearing a Latin inscription beginning with the words "*Hujus templi fundator.*"* Sir Robert Shirley married, circa 1647, Katherine, daughter of Humphrey Okeover, Esq., of Okeover, co. Staff., by his wife Martha, daughter of Sir Oliver Cheney, and by this lady, who died on 18th Oct. 1672, had three sons and two daughters. From the third son, Sir Robert Shirley, Bart., who was created Baron Ferrers in 1677, and Earl Ferrers in 1711, is directly descended the present representative of this ancient family, Sewallis Edward, 10th Earl Ferrers, owner of Staunton Harold, and of Chartley, co. Staff.

CASTLE DONINGTON.

SILVER CUP. Weight 16 oz. Height 8½ in. Diam. of bowl and of foot 4¾ in. Height of stem 3¼ in. Date 1732.

Hall marks. 1. Leopard's head crowned in a plain shield. 2. Capital Roman R in a plain shield. 3. Lion passant in oblong. 4. G S with a mark below in a shaped shield Mark of Gabriel Sleath.

The bowl of this cup is in shape an inverted truncated cone, having a raised rim round the lip. In front is the sacred monogram with a cross above and three nails below, within a circle of glory. The stem is thick, with a small moulding round its middle for a knob. Beneath the foot is this inscription ; "*The Gift of Selina, Countess of Huntingdon, to the Church and Parish of Castle Donington, in the year of our Lord 1732.*"

SILVER PATEN with foot. Weight 14.9 oz. Diam. 8¾ in. Diam. of foot 3½ in. Height of foot 1½ in. Date 1732.

Hall marks the same as those on the cup.

This is a plain paten, having in its centre the sacred monogram with cross and nails within a circle of glory. A moulding runs round its edge, and also round the edge of its foot. Underneath the paten there is the same inscription as the one on the cup.

SILVER FLAGON. Weight 46 oz. Height 12½ in. Diam. of top 4½ in. ; of foot 6½ in. Date 1732.

Hall marks the same as those on the cup.

This flagon is straight-sided in shape, narrowing a little towards the top. It has a round top to its lid, and a plain shaped handle. On the drum is the sacred monogram with the cross and nails within a circle of glory. Underneath the foot is the same inscription as the one on the cup.

In an undated terrier of this parish signed by John Collier, Vicar, made probably in 1709, this is all that is said of the utensils of this church,

* For rest see *Nichols*, Vol. iii., p. 714; and *Stonemata Shirleiana*, p. 153.

“Books, surplice, etc. in good condition.” From Archdeacon Bickham’s Inventory we find that there was here in 1776, in addition to the other pieces, “one small old cup used when visiting the sick, weight 6 oz. 13 drams.” This, alas, had ceased to be in existence in 1832.

The donor of this service was **Selina** “the good Countess of Huntingdon.” This lady was the second daughter of **Washington**, 2nd Earl **Ferrers**, by **Mary**, daughter of Sir **Richard Levinge**, Bart., and was born at Astwell House on 13th August, 1707. She was married in Staunton Harold church on 3rd June, 1728, to **Theophilus**, 9th Earl of **Huntingdon**.* This lady in early life was a devoted member of the church, to the doctrine and ritual of which she was much attached; the truth of which fact is shown in a small degree by the gift of communion plate to this her parish church, as well as to the church of Osgathorpe. After her husband’s death, which took place on 13th Oct. 1746, Lady **Huntingdon** was attracted into Calvinistic opinions by the eloquent preaching of Mr. **Whitfield**, and by degrees became one of that clergyman’s most ardent admirers and principal patrons. As soon as she had adopted the views of the Calvinistic Methodists, she hastened to build meeting-houses in which the teaching of that body might have a full opportunity of being set forth. But this course of action did not at first lead her into a separation from the church; she was an enthusiastic member of a certain party within it; and the principal teachers employed by her to expound the views within her meeting-houses were clergy of the church, most of whom were beneficed. Subsequently however, owing partly to the little sympathy shown towards her work by the rulers of the church, and partly to her own self-wilfulness, the good Countess and her friends adopted measures which were certainly contrary to the doctrine and discipline of the church, she finally becoming simply the pope to her own party, and the founder of a sect; her adherents saluting her as “the elect lady” and in other terms of that nature, which tended too well to strengthen her belief in her own infallibility. Yet nothing but admiration can be felt for the ascetic life led by this benefactress to the church of Donington, for her enthusiasm and liberality. The large sum of £100,000 was bestowed by her in different ways upon the connexion which she had founded; one of her gifts being the College of Trevecca for the training of students, which has since been moved to Cheshunt. The Countess of **Huntingdon**’s long life drew to an end at her house in Spa Fields, on 17th June, 1791. Those of her children who grew up were, **Francis**, who succeeded his father as 10th Earl of **Huntingdon**, and two daughters; the youngest of whom, **Selina**, died in 1763, on the eve of her marriage with her distant cousin Captain **George Hastings**; the eldest, **Elizabeth**, married

* *Stemmata Shirlitana*, p. 192.

the 1st Earl of **Moira**, and from her the more ancient titles of the **Hastings** family have been transmitted to the present Earl of **Loudoun**; the Earldom of **Huntingdon** passing to the son of the Captain **George Hastings** who was to have been the bridegroom of Lady **Selina**. The Countess of **Huntingdon** was buried in the vault under the chancel of Ashby church, her body being clothed in the white silk dress worn by her at the opening of Goodman's Fields chapel. Until recently no other memorial of her existed in Ashby church except the bust of herself by **Kent**, on the monument to her husband, which the Countess had placed after his death in the South transept, and on which is a long Latin inscription written by Lord **Bolingbroke**.* When however Ashby church was restored a few years ago, the congregation of Spa Fields chapel and some friends of the college of Cheshunt filled with painted glass a window at the West end of the church in memory of their foundress, the subject of the window being the Annunciation. They also placed in the chancel floor immediately over her grave, a black marble slab with an ornamental brass sunk into it; in the centre of which are these arms in a lozenge; *Quarterly*. 1. **Hastings**. 2. **Fitz-John**. 3. **Pole**. 4. **Plantagenet**, Duke of **Clarence**.† *On an escutcheon of pretence*; 1 and 8. *Paly of six Or and Azure, a canton Ermine*; **Shirley**: 2. *Or, three piles in point Gules, a canton Ermine*; **Basset** of Drayton. 3. *Azure a lion rampant between six cross crozlets Or*; **Braose**. 4. *Vairé, Argent and Sable, a canton Gules*; **Meynell**. 5. *Argent, a fess Gules in chief three torteaux*; **Devereux**. 6. *Vairé, Or and Gules*; **Ferrers** of Chartley. 7. *Argent, two bars Gules in chief three mullets of the last*; **Washington**: Supporters; *Two man tigers affrontée Or, their visages resembling the human face Proper*. Motto; "*In veritate victoria*." Beneath the Arms is a simple inscription concluding with the words of the "good countess"; "*I have nothing to do but to go to my Father*." Round the slab near the edge is an outer ornamental border of brass with the sacred monogram at each corner.

COLE ORTON.

SILVER CUP. Weight 13.4 oz. Height 8 $\frac{3}{8}$ in. Diam. of the bowl 4 $\frac{1}{4}$ in.: of the foot 3 $\frac{5}{8}$ in. Height of stem 4 in. Date 1818.

London hall marks.

This cup has a straight-sided bowl, rounded off below, on which is the sacred monogram a cross and three nails within a circle of glory. The stem swells out into a large round knob.

SILVER CUP. Weight 13.3 oz. Like the first.

* For which see *Nichols*, Vol. iii., p. 622.

† See dish belonging to Ashby.

SILVER PATEN with a foot. Weight 10.2 oz. Diam $7\frac{7}{8}$ in. Diam. of the foot $2\frac{1}{2}$ in. Height of foot $1\frac{1}{8}$ in. Date 1701.

Hall marks. 1. Court hand F. 2. Lion's head erased. 3. Britannia. 4. Capital Old English H and small o in a square with the corners clipped: the mark of *Samuel Hood*.

This paten has a flat edge round which is this inscription: "*Given to ye Parish of Coleorton in ye County of Leicester for ye use of ye H. Communion by James Hawkins Ao. Dom. 1701.*" The foot is a disk attached to the paten by a stem swelling out at both ends.

SILVER PLATE with a foot. Weight 12.2 oz. Diam. $7\frac{7}{8}$ in. Diam. of foot $3\frac{3}{4}$ in. Height of foot 2 in. Date 1818.

This is a plain plate with a raised edge and hollow foot.

SILVER FLAGON. Weight 36.6 oz. Height $10\frac{3}{4}$ in. Diam. at the top $3\frac{7}{8}$ in.; at the foot $6\frac{3}{8}$ in. Date 1818.

This is a straight-sided flagon narrowing towards the top, at which is a spout. In front is the sacred monogram.

SILVER GILT SPOON. Weight 0.3 oz. Length $4\frac{7}{8}$ in. Date *circa* 1740.

No marks.

This little spoon, possibly of Maltese manufacture, has a bowl of fine filigree work and a long round stem pointed at the end. Its original use was a tea strainer, the tea being poured through its bowl: its pointed handle served the purpose of clearing the leaves out of the spout of a teapot.

In the terrier of 1709 the plate of this parish is thus described; "A silver communion cup weighing $11\frac{1}{4}$ oz. with a silver paten weighing $11\frac{3}{4}$ oz. with this inscription round the rim, '*Given to the parish of Cole Orton for the use of the Holy Communion by ——— A Dom. 1701.*' One pewter flagon; two pewter plates and one pewter basin." The ancient cup was no longer here in 1832.

The terrier shows that when the silver paten was given in 1701 a blank was left for the name of the donor, and that after 1709 "**James Hawkins**" was inserted in that vacant space. As to him, nothing more can be said than that, he was no doubt a member of a family connected with this place and also with Measham co. Derby; the name appears in the registers of both parishes.

From Archdeacon **Bonney** we learn that the two cups the plate and the flagon were presented to this church by Sir **George Howland Beaumont**, Bart., D.C.L., and F.S.A. This public-spirited and talented gentleman was the only surviving son of Sir **George Beaumont**, 6th Bart. of Dunmow, co. Essex, and of Cole Orton, by **Rachael**, daughter of **Michael Howland**, Esq., of Stonehall, Essex, and was baptized at Dunmow on 17th Dec. 1753.

Sir **George**, who succeeded to the title as 7th Bart. on the death of his

father in 1762, and inherited the estates at Cole Orton which have been in the possession of this ancient family from the year 1426, was educated at Eton and New College, Oxford. He married on 6th May, 1778, **Margaret**, daughter of **John Willes**, Esq., of Astrop, Northants, and grand-daughter of Lord Chief Justice **Willes**. Together with his lady, Sir **George** made a tour in Italy in 1782, which confirmed and educated the taste which he already possessed for the arts. He had a sound knowledge, and was a liberal patron of art, and was himself a landscape painter of considerable skill, adopting the conventional style of **Richard Wilson**. It was one of his paintings that suggested the poem written by his friend **Wordsworth**, "Peele castle in a storm," in which the picture is spoken of thus:

"O 'tis a passionate Work! yet wise and well,
Well chosen is the spirit that is here."

But not only as a painter, rather as a promoter of artistic knowledge will Sir **George Beaumont** be ever remembered: for it is to him and others associated with him, that we owe the foundation of the National Gallery, which was successfully accomplished in 1824, owing in a great measure to his zeal and persistence. Two years after its foundation Sir **George** gave to the National Gallery the valuable collection of pictures which he had made for himself; a gift which could only have been effected at the cost of much self-denial, as is testified by a little anecdote related by Mrs. **Jameson**.* One piece in his collection, the landscape by **Claude** representing **Hagar** and **Ishmael** in the desert, had so attached itself to him, that after it had gone its absence was daily so painfully felt by its former owner, that finding he could not live happily without it, he was compelled to ask for it to be returned; a request which was at once granted. This picture was afterwards given back to the National Gallery by Lady **Beaumont**, who also presented two landscapes painted by her husband, one representing Jacques moralizing over the wounded stag; "*As you like it*," Act ii. Sir **George Howland Beaumont** died on 7th Feb. 1827, in the 73rd year of his age. His widow survived him for rather more than two years, dying upon 14th July, 1829, in the same year of her age. Both were buried at Cole Orton; where, in the church upon the East wall of the South aisle, is a white marble tablet to their memory bearing a short inscription. They having no children, Sir **George** was succeeded by his cousin, the grandfather of the present baronet.

The arms of Beaumont are; *Azure, semée of fleurs-de-lis and a lion rampant Or.*

* *Public Picture Galleries*, p. 5

The silver gilt spoon is the gift of the present rector of this parish, the Rev. **William Beresford Beaumont**, M.A. R.D.

DISEWORTH.

SILVER CUP. Weight 10.3 oz. Height $8\frac{1}{8}$ in. Diam. of bowl $3\frac{3}{8}$ in.; of foot $3\frac{1}{4}$ in. Height of stem $3\frac{3}{8}$ in. Date **1785**.

Hall marks. 1. Head of King **George III.** in intaglio. 2. Small Roman K. 3. Leopard's head crowned. 4. Lion passant. 5. J. K. in plain oblong; mark of *John King*.

This cup has a straight-sided concave bowl, a narrow stem, and a plain round foot.

PEWTER DISH. Diam. $9\frac{1}{4}$ in.

Marks. 1. X crowned. 2. Illegible, with "London" below. 3. Four small indistinct marks.

PEWTER DISH. Diam. $9\frac{1}{2}$ in.

No marks.

This is a pentagonal dish made in imitation of a silver salver: it has three feet, each being an eagle's claw holding a ball.

LOCKINGTON WITH HEMINGTON.

SILVER CUP. Weight 13.6 oz. Height $8\frac{3}{8}$ in. Diam. of bowl $4\frac{1}{8}$ in.; of foot $4\frac{3}{8}$ in. Height of stem 4 in. Date **1607**. (PLATE 6.)

Hall marks. 1. Lombardic K in plain shield. 2. Lion passant. 3. Leopard's head crowned: each of the two latter marks having an outside line following its outline. 4. Swan's neck in plain shield.

This cup has a deep bowl, an inverted truncated cone in shape; encircled with a narrow band of vine leaves and grapes arranged conventionally, and divided into three parts by large scrolls of foliage. The stem is evenly balanced, being divided in half by a round moulding on a fillet. Round the lower edge of the stem there is the vertical reed, and round the edge of the foot the egg and tongue ornament. Upon the bowl is this inscription;

" T B I E W
 Church R C W D " Wardens.

SILVER FLAGON. Weight 42.4 oz. Height $12\frac{1}{4}$ in. Diam. at top $3\frac{3}{8}$ in.; of foot $5\frac{3}{4}$ in. Date **1612**. (PLATE 6.)

Hall marks. 1. Lombardic P in plain shield. 2. Lion passant. 3. Leopard's head crowned, each of these two last having an outside line following its outline. 4. A bear passant with I. N. above within a circle.

This is the earliest example of a tankard-shaped flagon now belonging to any Leicestershire church. It is tall and straight-sided, narrowing slightly towards its top, which is covered with a lid much the same in shape as a beef-eater's hat. In front on the drum is this coat of arms; *Argent, a chevron embattled between three battle axes, Sable*: Crest; *A goat passant Sable*; **Bainbrigge**. (FIG. 3.) Below, is this inscription; "*Ex dono Johannis Bainbrigge arm patronus hujus parochialis ecclesie de Lockington in Comitatu Leicestrie ad Festum Paschæ Ano. Dom. 1638.*"* From this flagon having been given to the church some years after it was made, we learn that it was originally a secular piece of plate belonging to the Bainbrigge family.



Fig. 3.

TWO PEWTER DISHES. Diam. $9\frac{3}{8}$ in.

Marks. 1. "Compton, London" within a star. 2. "Superfine hard metal" in an oblong. 3. X crowned.

From Archdeacon **Bonney's** inventory we find there was here in 1832 in addition to these pieces, a silver paten given by **Mary**, widow of **John Bainbrigge** in 1718. There is every reason to believe that this was stolen some years ago.

The donor of the flagon was the representative of a family which settled here out of the North early in the sixteenth century; he was the eldest son of **William Bainbrigge**, of Lockington, by his second wife **Elizabeth**, the daughter of **Edward Charde**, of London, Esq., and was baptized on 15th Dec. 1573. **John Bainbrigge**, lord of the manor of Lockington, served the office of high sheriff of this county in 1630. He died on 10th March, 1642, and was buried in the chancel of Lockington church. Over his grave is a slab bearing a short inscription much worn, and a long poem, two lines of which are as follows;

"Ask the sad church and thou shalt read,
Loe here true piety lies dead." †

He married at Wigston in this county on 27th Feb. 1597, **Anne**, the daughter of **William Law**, of Great Wigston, Gent., who died on 3rd July, 1651; by whom he had a son **William**, his successor, and a daughter **Elizabeth**. ‡

The donor of the paten formerly here was **Mary**, the only child of **Thomas Harley**, of Osgathorpe, the founder of the school and alms-house in that place, by his third wife **Mary**, daughter and co-heir of **William**

* "The gift of John Bainbrigge, Esq., patron of this parish church of Lockington, in the county of Leicester. at the feast of Easter, in the year of our Lord, 1638."

† See *Nichols*, Vol. iii., p. 878.

‡ See *Leicestershire Pedigrees*, p. 169; by Rev. W. G. D. Fletcher.

Moore, of Walton on the Wolds. **Mary Harley** was born on 4th Aug. 1668. She became the wife of **John Bainbrigg**e of this place, the great grandson and representative of the donor of the flagon, who died on 1st Oct. 1717, aged 60. His widow survived until 4th June, 1724. She was buried in the old chancel of Osgathorpe church: over her grave was placed a white marble slab bearing an inscription, and these arms, **Bainbrigg**e; *impaling, Or, a bend cotticed, Sable; Harley*. When a new apse was built to this church and the chancel thrown into the nave in 1861, this slab was moved to its present position in the floor close to the North door, one of the stoves being placed over it. **Mary Bainbrigg**e's granddaughter, **Elizabeth Bainbrigg**e, ultimately became the last representative of the elder branch of the **Bainbrigg**e family, and was the last of that name to own the family estates, which she bequeathed to the Rev. **Philip Storey**, vicar of the parish. Part of the estates were some years ago sold to **N. C. Curzon**, Esq., of Lockington Hall.

OSGATHORPE.

SILVER CUP. Weight 8.2 oz. Height 7 in. Diam. of bowl and of foot $3\frac{3}{4}$ in. Height of stem 3 in. Date *circa* 1680.

One mark only, the maker's, I. S. in monogram within a dotted oval.*

The bowl of this cup is in shape an inverted truncated cone a little concave. The stem which has no knob, is quite plain in shape, gradually swelling into a plain foot. Upon one side of the bowl is the sacred monogram engraved in three simple Roman capitals; on the other side are the initials, "S. C." in the same style of letters.

SILVER CUP. Weight 10.6 oz. Height $7\frac{1}{2}$ in. Diam. of bowl $3\frac{3}{4}$ in.; of foot $3\frac{1}{2}$ in. Height of stem $3\frac{5}{8}$ in. Date 1732.

Hall marks. 1. Capital Roman R. 2. Leopard's head crowned. 3. Lion passant. 4. D. W. in plain oblong. Mark of *David Willaume*.

The bowl of this cup is in shape an inverted truncated cone, being rounded underneath. The stem is quite plain and has a small moulding for knob. Underneath the foot is this inscription, "*The gift of Selina Countess of Huntingdon to ye church and parish of Osgathorpe in ye County of Leicester, 1733.*"

SILVER COVER PATEN. Weight 3.7 oz. Diam. $4\frac{3}{8}$ in. Diam. of foot $1\frac{5}{8}$ in. Height of foot $\frac{7}{8}$ in. Date 1732.

Hall marks as on the cup.

This paten is quite flat having a flat edge about $\frac{3}{8}$ in. wide, raised about $\frac{1}{8}$ in. above the rest of the paten. It has the same inscription upon it as the cup.

SILVER DISH with foot. Weight 17 oz. Diam. $9\frac{1}{4}$ in. Diam. of foot $3\frac{1}{2}$ in. Height of foot $2\frac{3}{8}$ in. Date 1732.

No hall marks.

* See O. E. P. p. 327.

This dish is quite plain in shape, having the same inscription underneath as that on the cup.

SILVER FLAGON. Weight 40.2 oz. Height $10\frac{7}{8}$ in. Diam. at top $3\frac{3}{4}$ in.; at foot 6 in. Date 1732.

Hall marks as on cup.

This is in shape a straight-sided flagon narrowing towards the top, with a round top to its lid. It has the same inscription on it as the other pieces of this service.

TWO PEWTER PLATES. Diam. $8\frac{1}{2}$ in.

Marks. 1. X crowned. 2. W. C. And the following four small marks, Lion passant, a rose, Lion's head erased and W. I. P.

The initials "S. C." on the oldest cup probably stand for the name of the donor, of whom no certain clue can be traced.

The donor of the rest of this service, "the good Countess of **Huntingdon**,"* was connected with this parish through her husband the 9th Earl of **Huntingdon**, who was patron of the living.

PACKINGTON.

SILVER CUP. Weight 10.4 oz. Height $7\frac{3}{8}$ in. Diam. of the bowl $3\frac{3}{4}$ in.; of the foot $3\frac{3}{8}$ in. Height of stem $3\frac{3}{8}$ in. Date 1630. (PLATE 6.)

Hall marks. 1. Italic N in a plain shield. 2. Leopard's head crowned. 3. Lion passant, each within a shaped line. 4. R S, a mullet below, in a plain shield.

This cup has a bowl nearly straight-sided; standing on an evenly balanced stem which is divided in half by a large round knob, from whence it swells out to both ends. The foot is raised.

SILVER PATEN with a foot. Weight 3.2 oz. Diam. $4\frac{1}{2}$ in. Diam. of foot 2 in. Height $\frac{7}{8}$ in. Date 1630. (PLATE 6.)

Same hall marks as those on the cup.

This paten, which fits on to the cup with the foot downwards, has a flat edge $\frac{1}{2}$ an inch wide, the middle being sunk flat $\frac{1}{4}$ inch in depth. The foot is a disk attached to the paten by a stem swelling out at both ends.

SILVER PLATED FLAGON. Height $11\frac{3}{4}$ in. Diam. at the top $3\frac{1}{2}$ in.; at the foot $5\frac{1}{2}$ in.

This is a straight-sided flagon narrowing to the top, at which is a spout.

TWO SILVER PLATED PLATES. Diam. of each 9 in.

In the centre of each is the sacred monogram with a cross and three nails within a circle of glory.

With the Lincoln terriers is a document sent from this parish containing

* See Castle Donington.

answers to questions set by Bishop Tomline in 1812, in which the plate here and at Snibston is shortly noted as follows "A cup at each church."

In 1630 Henry, 5th Earl of Huntingdon, was lord of the manor, and owner of most of the soil of Packington.

SNIBSTON.

SILVER CUP. Weight 4.6 oz. Height $4\frac{7}{8}$ in. Diam. of the bowl $3\frac{5}{8}$ in. of the foot 3 in. Height of stem 2 in. Date *circa* 1575. (PLATE I.)

No hall marks.

This little cup has a bowl shaped into an inverted truncated cone, concave, with a flat projecting base, a narrow moulding running round its edge. Round the upper part of the bowl is an engraved band of stroke ornament divided into six parts by hour-glass curves. The stem is short and evenly balanced being divided in half by a small round between two lines for a knob, from whence it swells out a little to both ends: the usual vertical ends are wanting, and have possibly been taken out when the cup has been repaired. The foot is rounded off into a flat edge. This cup is probably the work of the maker who used the "rose" for his mark.

TWO PEWTER PLATES. Diam. of each $8\frac{3}{4}$ in.

Marks. 1. This coat within an ornamental shield, per chevron engrailed three talbots heads erased; "S. Duncumb" above. 2. "London" on a scroll.

NETHER SEALE.

(a)

SILVER CUP, parcel gilt. Weight 12 oz. Height $8\frac{3}{8}$ in. Diam. of the bowl $4\frac{1}{4}$ in.; of the foot $4\frac{3}{4}$ in. Height of stem $5\frac{1}{2}$ in. Date 1874.

London hall marks.

The bowl of this cup is shaped into an inverted truncated cone, having round its middle; "*Hic est calix sanguinis mei;*" between the first and last word is a cross formed with five amethysts set separately in gold. The bowl stands upon a straight round stem, divided in half by a large round knob, which, with the stem, is covered with a lattice-shaped ornament. The lower part of the stem swells into a round foot, ornamented with conventional foliage on which are four large amethysts set at equal distances; on the lower part of the bowl is this inscription; "*In memory of Isabella and Katharine Sergison who were burned to death at Netherseale Hall, on May 10th, 1874.*"

(b)

SILVER PATEN, parcel gilt. Weight 5.3 oz. Diam. $6\frac{1}{4}$ in. Date 1874.

This paten has a flat edge its middle part being sunk flat. In the centre is the Agnus Dei within an ornamental circle, and round the edge an engraved band of conventional foliage on which are ten amethysts set in gold. On the back of the paten is this inscription; "*Given as a thankoffering for Isabella F. S. Robertson's and Katherine L. E. Robertson's deliverance from death by fire on 10th May, 1874.*"

(c)

SILVER FLAGON, parcel gilt. Weight 21.8 oz. Height 11 in. Diam. at the top 2½ in. At the foot 3¼ in. Date 1860.

Birmingham hall marks.

This is a jug-shaped flagon having a wide middle narrowing into a tall neck. It has a conical lid surmounted by a double cross bottonné. The handle terminates at each end in grape and vine leaves. Round the middle of the flagon is an ornamental band on which is "*Drink ye all of this.*"

In the terrier of 1709, the church plate here is simply mentioned thus; "The communion plate weighs 6 oz." This probably Elizabethan cup seems to have been replaced before 1777 with another, when, according to Archdeacon **Bickham**, the service here consisted of "one silver cup weight 9 oz. 13 dwts.; one silver basin 6 oz. 9 dwts.; one silver salver 8 oz. 0 dwts." Archdeacon **Bonney** mentions this service, and also a large pewter flagon with a top inscribed "*Nether Seale. Zach. Gilbard.*"

The three silver pieces were melted down, a portion of the metal being used in the manufacture of the present cup and paten. At the time this church was restored in 1872, there were placed within the pewter flagon a copy of the *Times* newspaper and a few coins, the lid was then soldered down, and the vessel was built into the North East buttress of the chancel wall; a date cut on the stone outside marks the spot of its interment.

(a)

The modern cup was presented to this church by the Rev. **W. T.** and Mrs. **Sergison**, in memory, as the inscription tells us, of their daughters **Isabel Mary Katherine** and **Katherine Agnes Emily Fraser Sergison**. These two young ladies, aged 19 and 17, were paying a visit at Netherseale Hall, the seat of their relative, the late **E. W. Robertson**, Esq., when they met with their death in a most distressing manner. The principal object of their visit was to be present at the re-opening of this church after restoration, which took place on 6th May, 1874. On the following Sunday evening the younger of the sisters standing too close to the drawing-room fire allowed her dress to be set alight; her elder sister ran to her help, only to be enveloped in flames herself. Mrs. **Robertson** and her daughter in bravely endeavouring to render help met with the like result. The Miss **Sergisons** were so badly burnt that they survived but for a few hours, dying on Monday, May 11th. Their sad death is recorded by means of this gift made in their memory to this church by their parents. Their father was the Rev. **William Thomas Sergison**, the second son of the Rev. **William St. Pritchard**, (afterwards **Sergison**), by his wife **Anne Sergison**,* and was born on 10th June, 1802.

* See *Burke's Landed Gentry*.

Mr. **Sergison** was appointed to the living of Slaugham, Sussex, in 1839, and held it until his death on 15th June, 1874: he was also a prebendary of Chichester. Their mother who survives her husband is **Catherine Frances Eleonora**, the second daughter of the late Major **William Colegrave**, of Cann Hall, Essex, by **Catherine**, eldest daughter of General Sir **John Fraser**, G.C.H. This lady was Mr. **Sergison's** second wife.

(b)

The paten was presented by Mrs. **Robertson** as the inscription thereon tells us, as a thank-offering for the preservation of herself and her eldest daughter from death by fire. The donor of this paten is **Isabella Frances Sarah**, the youngest daughter of the late Major **William Colegrave**; she was therefore aunt to the Miss **Sergisons**. This lady was married to **Eben William Robertson**, Esq., on 11th June, 1838, and survives her husband. Mr. **Robertson**, who died in 1874, bought Nether Seale Hall from the late Sir **Thomas Gresley**, Bart.; and inherited his other property of Chilcote, co. Derby, from his father, who bought it from **E. S. Chandos-Pole**, Esq., of Radburne.

(c)

The silver flagon was the gift of Captain **Frederick Bernard Bosanquet**, formerly of the Bengal army. This gentleman, a younger son of the late **Samuel Bosanquet**, Esq., of the Forest House, Essex, became connected with this parish through his purchase of The Shrubbery, Over Seale, where he formerly resided for hunting. He now lives in Devonshire.

OVER SEALE.

SILVER CUP. Weight 18.6 oz. Height $9\frac{3}{4}$ in. Diam. of the bowl $4\frac{7}{8}$ in.; of the foot $5\frac{3}{8}$ in. Height of stem $6\frac{1}{2}$ in. Date 1841.

London hall marks.

This cup has a straight-sided bowl rounded off below, standing on an octagonal stem and foot, which are ornamented with designs of a quasi-gothic character in relief. Upon the bowl is the sacred monogram in capital old English letters in relief.

SILVER PATEN with foot. Weight 18.9 oz. Diam. $7\frac{1}{2}$ in. Diam. of the foot $4\frac{3}{8}$ in. Height of foot 4 in. Date 1841.

This is a plain paten resting on an octagonal stem and foot much the same in shape as the stem and foot of the cup. In the centre is the sacred monogram in relief.

SILVER DISH. Weight 19.3 oz. Diam. $9\frac{7}{8}$ in. Date 1841.

This piece is also quite plain, having the sacred monogram in its centre.

SILVER FLAGON. Weight 47.5 oz. Height $15\frac{1}{2}$ in. Diam. at the top $4\frac{3}{8}$ in.: at the foot $7\frac{1}{2}$ in. Date 1841.

This is a tall straight-sided flagon with concave sides swelling out below into an octagonal foot the same in shape as the foot of the cup. It has a raised lid surmounted by a cross patonce; and a round handle terminating at each end in a large leaf. In front is the sacred monogram in relief.

This very solid service of church plate is kept in an oak box, on the lid of which is this inscription; "*This communion plate was the gift of the relatives of the late Elizabeth Pycroft to the chapel of Overseale 1841.*"

This maiden lady, to whose memory her relatives presented this gift, belonged to a family owning land in this parish and also in Burton-on-Trent.* She was the daughter of **William Pycroft**, of the manor house Burton-on-Trent, by his wife **Elizabeth Wilkes**, and was baptized at Burton on 11th Dec., 1759.† She was doubly connected with this parish since her mother became the second wife of the Rev. **Thomas Gresley**, D.D., rector of Seale. At Overseale this lady "the most charming of companions and greatly beloved by rich and poor," spent most of her long life, towards the close of which she took a considerable share in the building of the present church, as is testified by this inscription on a tablet inside:

"*This Tablet is erected in memory of Elizabeth Pycroft of Overseal, who died Dec. 19th, A.D., 1840, much beloved and lamented. Aged 83 years.*"

"*The land for the site of this chapel and chapel yard was the free gift of this charitable lady, in addition to a donation towards the building, of which she laid the first stone August 27th, A.D. 1840.*"

"*The Communion Plate, Stone Table, and velvet covering were offerings from the relations of the deceased, to record their sense of the worth and excellency of her character, as well as of her zeal for the Glory of God and the honour of His House.*"

She was buried next to her mother at Netherseale on 26th December.

By her will, made on 30th Dec. 1833, and proved with two codicils in London on 28th Jan. 1841, **Elizabeth Pycroft** left many legacies to distant relations and friends; amongst others, to **James, John** and **Joseph**, sons of her father's cousin **James Pycroft**. She had the disposal of property left to her by her brother, **Joseph Pycroft** of Burton-on-Trent; her executors were **William Daniel**, of Burton-on-Trent, and **Joseph Simmonds**.

SWEPSTON.

SILVER CUP WITH COVER PATEN. Weight of cup 5.9 oz. Height 5½ in. Diam. of the bowl 3¾ in.; of the foot 3½ in. Height of stem 2¼ in. Date 1577. (PLATE 4.)

Maker's mark only; a plain cross between four pellets within a dotted circle.

* Shaw's *Hist. of Staffs.*, Vol. i., p. 12.

† Parish Register.

This cup has a bowl shaped into an inverted truncated cone, slightly concave, with a flat projecting base. Round the bowl is a band of stroke ornament divided into four parts by hour-glass curves. The bowl rests upon a short thick and evenly balanced stem, divided in half by a round between two hollow mouldings for a knob; from whence it swells out to each end into vertical edges ornamented with reeds. The foot is a wide one and is finished off with a vertical and flat edge, a reed ornament running round the former. Round the top of the foot is an engraved band $\frac{1}{2}$ an inch wide, similar to the one round the bowl.

SILVER COVER PATEN with a foot. Weight 1.6 oz. Diam. $3\frac{3}{4}$ in. Diam. of foot 1 in. Height of foot $\frac{5}{8}$ in. (PLATE 4.)

No marks.

This paten has a flat edge $\frac{1}{4}$ of an inch wide, round which is the usual rim inside: the middle is sunk only a little. Round its top is an engraved band of stroke-ornament. The foot is a disk attached to the paten by a round stem swelling out a little at both ends. Round the foot is this inscription; "*God save the Quine*"; and on the middle is the date "1577."

SILVER PLATED CUP. Height $8\frac{3}{4}$ in. Diam. of the bowl $3\frac{3}{4}$ in.; of the foot $3\frac{3}{8}$ in. Height of Stem $3\frac{1}{2}$ in.

Mark. Cross keys within a square. W. K. below.

This cup has a straight-sided concave bowl standing on a narrow stem having a round knob. Upon the bowl is the sacred monogram with a cross and three nails within a circle of glory.

SILVER PLATED PATEN with a foot. Diam. $7\frac{3}{4}$ in. Diam. of foot $3\frac{3}{4}$ in. Height of foot $3\frac{1}{2}$ in.

This is a plain paten with the sacred monogram in the centre.

SILVER PLATED DISH. Diam. 9 in.

In the centre is the sacred monogram.

SILVER PLATED FLAGON. Height $12\frac{1}{4}$ in. Diam. at the top $3\frac{5}{8}$ in. At the foot 6 in.

This is a straight-sided flagon narrowing towards the top, having the sacred monogram in front. Each of these pieces are plated on copper.

In 1577 the lord of the manor and owner of most of the soil of Swepston was **William Humphrey**, who died on 3rd March, 1591. To his memory is an altar-tomb surmounted by his effigy at the West end of this church close by the South door. This monument was formerly between the pulpit and chancel.

SNARESTONE.

SILVER CUP WITH COVER PATEN. Weight of Cup 8.9 oz. Height $7\frac{1}{2}$ in. Diam. of the bowl $3\frac{7}{8}$ in.; of the foot $3\frac{5}{8}$ in. Height of stem $3\frac{1}{2}$ in. Date 1635.

Hall marks. 1. Italic S in a plain shield. 2. Leopard's head crowned within an outer line following the shape of the stamp. 3. Lion passant within ditto. 4. B E crowned within a shaped shield.

This cup has a bowl shaped into an inverted truncated cone with a flat base, standing upon a conical-shaped stem; near the top of which is a plain disk $1\frac{1}{2}$ in. in diameter; from whence the stem swells out gradually into the foot which ends in a plain, vertical and flat edge: beneath the foot is the Lion passant. Upon the bowl is this inscription, "*Suarkestone Com'union Cup and Cover.*"

SILVER COVER PATEN with a foot. Weight 3 oz. Diam. $4\frac{1}{4}$ in. Diam. of the foot 2 in. Height of foot $\frac{3}{4}$ in. Date, possibly 1651.

Hall marks. 1. Possibly court hand O in a plain shield. 2. Leopard's head crowned within a shaped line. 3. Lion passant within ditto. 4. B E, three pellets above, a fleur-de-lis below, within a plain shield.

This paten has a flat edge $\frac{3}{4}$ of an inch wide, with a rim inside, from whence the cover is slightly sunk. The foot is a disk attached to the paten by a round stem swelling out at both ends. The date letter is not exactly like any in Mr. Cripps' list: it is an O bisected by a vertical line. The maker's mark also varies from the one on the cup. It is not unlikely but that the original cover had to be, from some cause or another, replaced in 1651: by which time the maker had altered the design of his mark, and had copied the example of his rulers in abolishing the crown.

SILVER PLATED DISH with a foot. Diam. $9\frac{1}{4}$ in. Diam. of the foot $4\frac{1}{4}$ in. Height of foot $2\frac{1}{4}$ in.

This is a perfectly plain solid dish.

SILVER PLATED FLAGON. Height $10\frac{1}{4}$ in. Diam. at the top $3\frac{5}{8}$ in. At the foot 6 in.

This is a plain straight-sided flagon, narrowing to the top. It and the dish were bought by the parishioners about forty years ago to take the place of an old pewter flagon and plate. In 1635 and 1651 **Thomas Charnells** was lord of the manor of Snarkestone.

WHITWICK.

SILVER CUP. Weight 14.1 oz. Height $7\frac{5}{8}$ in. Diam. of the bowl $4\frac{1}{4}$ in.; of the foot 5 in. Height of stem 5 in. Date 1849.

London hall marks.

This cup has a globular-shaped bowl, gilt inside, resting on an hexagonal-shaped stem, which is divided in half by an hexagonal knob ornamented with diamond-shaped bosses and open tracery. The foot is shaped into six lobes, the sacred monogram being engraved on one of them. Underneath the foot is "*St. John the Baptist, Easter, Ao Dni. Mdcclii.*"

SILVER PATEN. Weight 4.4 oz. Diam. $6\frac{1}{2}$ in. Date 1849.

This paten has a flat edge on which is; "*Agnus Dei qui tollis peccata mundi miserere nobis.*" The middle part is sunk in a six-lobed depression, having in its centre the Agnus Dei gilt.

SILVER FLAGON. Weight 18.2 oz. Height 12 in. Diam. at the top 2 in.; at the foot 4 in. Date 1848.

This is a jug-shaped flagon with a spout formed by a narrow tube rising up out of its middle. Round its middle is; "*Adjutorum nostrum in nomine domini.*" Under the foot is the same inscription as that under the foot of the cup, which is also placed under the paten.

SILVER PLATED PLATE. Diam. $9\frac{3}{4}$ in.

This is an hexagonal-shaped plate with a gadrooned edge.

In 1832 Archdeacon **Bonney** tells us that the communion service here consisted of "an old pewter flagon, an ancient silver cup with a silver top, a silver plated dish." The last piece only still remains here.

The origin of the new silver service is told by this inscription on the box in which it is kept. "*This communion service was presented to the parish Church of St. John Baptist, Whitwick, by Rev. Francis Merewether, M.A., Vicar, and Rev. Samuel Smith, M.A., Curate, aided by the devotions of Personal Friends, Easter, MDCCCL.*"

The name first mentioned in this inscription was for many years an honoured one in this neighbourhood, as well as in a circle considerably wider than that of his own district. Mr. **Merewether** sprang from a family which has produced many members, each honoured in his calling like himself. His great-grandfather was **John Merewether**, M.D., of Devizes, the friend of **Isaack Walton** and Bishop **Ken**, the latter being attended by him in his last illness. Dr. **Merewether** was also connected with the families of both those worthies by marriage as well as friendship, inasmuch as his daughter **Jane**, who was celebrated for her beauty, married **William Hawkins**, the grandson of **Isaack Walton**, and the great-nephew, executor and biographer of Bishop **Ken**. The doctor's great-grandson **Francis Merewether**, was the son of **Henry Merewether**, solicitor, and land agent, of Calne, co. Wilts, by **Mary White**, and was born on 1st Feb. 1784. He was educated first under Dr. **Valpy**, at Reading, and then at Eton, from whence he went to Christ Church, Oxford, taking his B.A. degree in 1806. Afterwards, he took advantage of his proximity to Cambridge, by becoming in 1809, an M.A. of St. John's College, in that University. In 1808, he was presented by Sir **G. H. Beaumont**, Bart., to the vicarage of Haverhill, in Essex and Suffolk, which he held till 1815, when he was presented by the same patron to Cole Orton rectory, the Crown appointing him to the vicarage of Whitwick four years later. In both his cures Mr. **Merewether** was a painstaking parish priest. At Haverhill he established a national school, the first to be built in the county of Suffolk; afterwards, during his long abode in Leicestershire he did much to extend the work of the church within his populous parishes. With the liberal assistance of Sir **G. H.** and Lady **Beaumont**, and the help of other friends, he founded the district of St. George's, Whitwick, providing it with schools, church, and parsonage. He originated the same good work in the present village of Coalville: and afterwards also at St. Andrew's, Whitwick. And while, owing to the increase of his population through the discovery of coal, he was founding these three new districts, Mr.

Merewether was not forgetful of the needs of his people living close around his two ancient churches. With his kind friend and ready supporter, Sir **G. H. Beaumont**, he co-operated zealously in the improvement of Cole Orton church; and with the help of other friends, changed the parish church of Whitwick from a somewhat neglected state, into its present carefully restored condition. Outside his own parishes, he took an active interest in the welfare of the church, and was associated at different times with such men as **Christopher Wordsworth**, **H. H. Norris**, **Joshua Watson**, and **Henry Hoare** in various movements, the revival of convocation being one: to promote such works he published several sermons and pamphlets.* These latter however were not always upon strictly ecclesiastical subjects; some were written upon topics political and social, in which he took an active interest; in the latter especially, as is shown in his being one of the founders of the first Leicestershire Agricultural Society. Full of days and revered by all his friends, by whom in their affectionate esteem he had been given the title of "the patriarch," he died on 21st July, 1864: his grave, which is in Cole Orton church yard east of the chancel, is marked by a recumbent monument bearing a short inscription. Mr. **Merewether** married on 24th April, 1810, **Frances Eliza**, eldest daughter of **Gregory Lewis Way**, Esq., of Spencer Farm, Essex, by **Ann Frances**, daughter of Rev. **William Paxton**, rector of Taplow. Mrs. **Merewether** died 4th Feb., 1870, and was buried at Great Yeldham. She bore her husband three sons and one daughter, *viz.*, **Francis L. S. Merewether**, formerly Auditor General of New South Wales and Chancellor of the University of Sydney, now of Ingatestone Hall, co. Essex; the Rev. **Henry R. Merewether**, B.A., Vicar of East Peckham, Kent; the late **Charles G. Merewether**, Q.C., Recorder of Leicester and M.P. for Northampton 1874-1880; **Emily Mary Annette**, wife of the Rev. **G. Currey**, D.D., Prebendary of St. Paul's and Master of the Charterhouse.

Mr. **Merewether** bore these arms, *Or three martlets Sable on a chief Azure a sun in splendour proper; Merewether; quartering; Or a saltire engrailed between twelve billets Sable; Alworth.* Crest; *An arm embowed in armour garnished Or, holding in the hand proper a sword of the last, hilt and pommel Or, entwined round the blade with a snake proper.* Motto; "*Vi et Consilio.*"

The Rev. **Samuel Smith**, the other donor named in the inscription, was the third son of **Samuel Smith**, Esq., of Leeds, by his wife **Amelia**, second daughter and co-heir of **George Pyemont**, Esq., of Tanshelf, co. York, and was born 12th May, 1820. Educated at Durham University, he served first

* See *Memoir of H. Hoare*, by J. B. Sweet, pp. 70 and 305. Also *Guardian*, July 27, 1864, and *Crochford's Clerical Directory* for pamphlets.

as curate under Mr. **Merewether**, who in 1851 presented him to St. George's, Whitwick: In 1864 he was transferred to the vicarage of Whitwick, which post he held until his death on 14th March, 1875. The Rev. **Samuel Smith** married 25th Sep. 1841, **Frances Anne**, daughter of **Thomas Oxley**, Esq., of Pontefract, M.D., who survives him, and by this union had three sons and three daughters, the eldest son being the Rev. **Francis Samuel Pyemont**. A few years before his death Mr. **Smith**, Vicar of Whitwick, took the name of **Pyemont**, owing to his elder brother **John** having assumed that name in compliance with the wishes of their cousin **Samuel Pyemont**, Esq.*

ST. GEORGE'S. WHITWICK.

SILVER PLATED CUP. Height 6 $\frac{5}{8}$ in. Diam. of the bowl 4 in.; of the foot 3 $\frac{1}{2}$ in. Height of stem 2 $\frac{1}{2}$ in.

This cup has a straight-sided bowl with a bell-shaped lip, standing on a short narrow round stem which swells out towards the bowl and into a square foot. Underneath the foot is "*St. George's Church, Whittick.*"

SILVER PLATED PATEN. Diam. 8 $\frac{1}{2}$ in.

This is a plain salver with a gadrooned edge and three round feet below. Both this and the cup are plated on copper.

SILVER ELECTRO-PLATED FLAGON. Height 8 $\frac{1}{2}$ in. Diam. at the top 3 in.; at the foot 4 in.

This is a straight-sided flagon narrowing towards the top.

The cup and paten were provided for this church when it was built in 1825 as a chapel of ease to Whitwick. The flagon was bought a few years ago by the parishioners.

ST. ANDREW'S. WHITWICK.

SILVER CUP. Weight 15.2 oz. Height 7 $\frac{1}{2}$ in. Diam. of the bowl 4 in.; of the foot 5 $\frac{1}{8}$ in. Height of stem 5 in. Date 1862.

London hall marks.

This cup has a globular bowl resting on an hexagonal stem which is divided in half by a large knob, ornamented with six diamond-shaped bosses with open tracery between. The foot is shaped into six lobes. Upon the bowl is engraved a cross *bottonnée* within a circle, and on the foot the sacred monogram.

SILVER PATEN. Weight 4 oz. Diam. 7 $\frac{5}{8}$ in. Date 1862.

This paten has a flat edge upon which is "*Lord, evermore give us this bread.*" The middle is sunk in six lobes; in the centre is the sacred monogram within a circle, gilt.

* See Burke's *Landed Gentry*.

SILVER PLATED FLAGON. Height $8\frac{3}{8}$ in. Diam. at the top $2\frac{1}{2}$ in.; at the foot $2\frac{1}{2}$ in. Date *circa* 1830.

This is a small jug-shaped flagon, its lid being surmounted with a plain cross. The lower part is covered with engraved conventional foliage. Underneath the foot is "*St. Andrew's, Thringstone, Easter 1881.*" This was formerly a secular piece of plate; "C. N.," the initials of its former owner, **Catherine Newell**, being engraved upon one side of it.

The silver cup and paten were presented on St. Andrew's Day, 1862, the day upon which this church was consecrated as a chapel of ease to Whitwick. They were purchased by voluntary subscriptions raised by the then vicar of Whitwick, the Rev. **F. Merewether**.

The flagon is the gift of the present vicar of St. Andrew's, the Rev. **Edwin Samuel Crane**.

WOODVILLE.

SILVER CUP. Weight 6.5 oz. Height $6\frac{1}{8}$ in. Diam. of the bowl $3\frac{1}{2}$ in.; of the foot 3 in. Height of stem 3 in. Date 1790.

Hall marks. 1. Small Roman P in a square shield. 2. Leopard's head crowned in an oval shield. 3. Lion passant in a plain oblong. 4. Head of King George III. 5. I. Y. in a plain oblong. Mark of *James Young*.

This cup has an egg-shaped bowl and a narrow round stem swelling out towards the bowl and into a plain round foot. Upon the bowl is this inscription; "*Ecclesie S^{ta}. Stephani de Woodville, D.D., Gualterius Aug^{us}. Shirley, A.M., Archd^e. de Derby, 1846.*"

SILVER PATEN. Weight 4.3 oz. Diam. $6\frac{5}{8}$ in. Date 1846.

London hall marks.

This paten has a flat edge from which the middle part is sunk flat. In the centre is the sacred monogram within a circle of glory. Round the edge is "*Per mysterium sancte incarnationis tue libera nos domine.*"

SILVER FLAGON. Weight 16.6 oz. Height $10\frac{1}{2}$ in. Diam. at the top $1\frac{7}{8}$ in.; at the foot $4\frac{1}{4}$ in. Date 1846.

London hall marks.

This is a jug-shaped flagon having round its middle "*Gloria in excelsis Deo alleluia.*" Underneath the foot is "*In usum Ecclesie Sti. Stephani de Woodville. mdcccxlii.*"

This communion service was presented to Woodville church on the day of its consecration, 8th Dec., 1846.

The donor of the cup was the Venerable **Walter Augustus Shirley**, at that time Archdeacon of Derby. This gentleman, who sprang from a younger branch of the ancient family of **Shirley** and was a descendant of Sir **Robert Shirley**, 4th Bart., of Staunton Harold, was the only son of the Rev. **Walter Shirley**, Rector of Brailsford, co. Derby, by **Alicia**, daughter of Sir

Edward Newenham, and was born at West Port, co. Mayo, on 30th May, 1797. He was educated at Winchester and New College; and upon taking orders was presented to the vicarage of Shirley, co. Derby. He afterwards held the two following pieces of preferment, Whiston rectory, co. York, and Brailsford, co. Derby. While incumbent of the latter parish Mr. **Shirley** was promoted to the Archdeaconry of Derby, which he held until 10th Jan., 1847, on which day he was consecrated Bishop of Sodor and Man. The Right Rev. Dr. **W. A. Shirley** was a bishop but for a few weeks, for he died at Bishop's Court, Isle of Man, on 21st April, 1847. He was buried in a vault under the North aisle of Shirley church, where there is a tablet to the memory of himself and his wife. The value in which Dr. **Shirley's** work was held by the members of his Archdeaconry and other friends is shown in the church of St. Paul, Derby, which was built in his memory. Bishop **Shirley** married at Paris on 4th Sep., 1827, **Maria**, daughter of **William Waddington**, Esq., by which lady, who died on 10th Jan., 1854, he had a son, **Walter Waddington**, D.D., Canon of Christ's Church, Oxford, and a daughter, **Alicia Maria**, married to **Claudius Harris**, Esq.*

The paten and flagon were the gift of the Rev. **James Bradby Sweet**, now vicar of Otterton, Devon, who was the first incumbent of this parish, and under whose auspices this district was formed and the church built.

WORTHINGTON.

SILVER CUP. Weight 8.6 oz. including lead in stem. Height $6\frac{1}{4}$ in. Diam. of bowl 3 in.; of foot $2\frac{7}{8}$ in. Height of stem 3 in. Date **1569.** (PLATE 4.)

Hall marks. 1. Small black letter M. 2. Lion passant. 3. Leopard's head crowned; each of these two marks having a line outside following the shape of their outline. 4. Maker's mark, illegible.

The bowl of this cup is in shape nearly straight-sided, swelling out a little towards the lip: round its middle is a narrow engraved band, divided in four parts by hour-glass curves, within which is the usual foliage, rather rudely done. The stem is evenly balanced, being divided in half by a plain round moulding on a fillet for a knob. The egg-ornament runs round the edge of the foot. Here is an example of the evil consequences of filling the stem of a cup with lead, which in this case has caused the stem to be cracked quite through all round. The lead having been the cause of this injury now does some service by holding the stem on to the bowl.

* For full account of the life and work of this excellent divine see *Memoir*, by late Archdeacon Hill, London, 1849: and "*Stemmata Shirleiana*, p. 205."

SILVER PLATED FLAGON. Height $11\frac{1}{2}$ in. Diam. at top $3\frac{3}{4}$ in.; at foot $5\frac{1}{4}$ in.

Mark, "*James Dixon and Sons.*"

In shape this is a straight-sided flagon narrowing a little towards the top.

PEWTER DISH. Diam. $9\frac{1}{2}$ in.

Marks. 1. X crowned. 2. Horses jamb, rising out of a ducal crown; "*London*" below.

3. S. D. Lion's head erased; and another mark; each in a small plain shield.

PEWTER DISH. Diam. 9 in.

Mark. "*James Dixon and Sons Sheffield.*"

In 1569 **George Winter** was lord of the manor of Worthington.



1290052

"'How,' said Sir Gawaine, . . . 'I will make here arow, that to-morn, without longer abiding, I shall labour in the quest of the Sancgreal.'"

Morte d'Arthur.

AKELEY EAST DEANERY.

ANSTEY.
 BARROW-ON-SOAR.
 GRIMSTON.
 WARTNABY.
 HATHERN.
 KEGWORTH.
 ISLEY WALTON.
 LONG WHATTON.
 LOUGHBOROUGH.
 ALL SAINTS.

LOUGHBOROUGH, *Continued.*
 EMMANUEL.
 HOLY TRINITY.
 MOUNTSORREL.
 CHRIST CHURCH.
 ST. PETER.
 OAKS.
 COPT OAK.
 QUORNDON.

ROTHLEY.
 SHEEPSHED.
 SWITHLAND.
 THORPE ACRE.
 DISHLEY.
 THURCASTON.
 WANLIP.
 WOODHOUSE.
 WOODHOUSE EAVES.



ANSTEY.

SILVER CUP. Weight 17.4 oz. Height 9 in. Diam. of the bowl $4\frac{3}{8}$ in. ; of the foot $3\frac{3}{8}$ in. Height of stem 4 in. Date 1832.

Sheffield hall marks.

This cup has a straight-sided concave bowl with a raised lip and a narrow stem with a plain round knob in its middle; the foot is filled up underneath with a piece of wood. Upon the bowl is this inscription; "*To the service of God and to the Episcopal Chapel of Anstey. Humbly dedicated by Elizabeth Roby, Sept. 29th, 1832.*"

SILVER CUP. Weight 13.3 oz. Height 8 in. Diam. of the bowl 4 in. ; of the foot $5\frac{1}{8}$ in. Height of stem $5\frac{3}{8}$ in. Date 1879.

London hall marks.

This cup has a globular-shaped bowl, a hexagonal stem and knob; with a foot shaped into six lobes.

SILVER PATEN. Weight 4.2 oz. Diam. $5\frac{3}{4}$ in. Date 1879.

London hall marks.

This is a plain paten with a cross within a circle on its edge.

SILVER PLATED PATEN with a foot. Diam. 6 in. ; Diam. of the foot $2\frac{1}{2}$ in. Height of foot $\frac{7}{8}$ in.

This is a perfectly plain paten.

GLASS CRUET with silver mountings. Height $11\frac{1}{2}$ in.

This cruet has a silver top and stopper on which stands a double cross.

TWO PEWTER PLATES. Diam. of each $9\frac{1}{2}$ in.

Marks. 1. On the edge, "A. W. S." 2. Underneath; in three small shields, Leopard's face; Lion rampant, with a fleur-de-lis below and a pellet in each corner; A fleur-de-lis, with two mullets of six points above. 3. Within an oval, an eagle displayed; above is "... h," below, "Giddings." 4. Within an oval, a rose crowned.

From a terrier at Lincoln for this parish, with Thurcaston, we learn that the church plate of Anstey in 1709 consisted of; "two pewter flagons," one of them inscribed "**William Glover**;" one pewter cup with a cover, inscribed "G. M.," and two patens inscribed "A. W. S." The same plate is mentioned in the terrier for 1745. From the terrier for 1788 we find that while the flagon and patens were still in use, the pewter cup and cover had been replaced by "one plated cup."

William Glover, the donor of one of the pewter flagons formerly here, was a freeholder in Anstey in 1630.

The donor of the first silver cup, Miss **Elizabeth Roby**, was one of the many daughters of **Thomas Roby**, freeholder, of Castle Donington, by **Elizabeth**, daughter and heir of **Robert Bradshaw**, of Ulverscroft; which lady was the last member of her family; she therefore by her marriage on 1st Feb., 1759, brought the **Bradshaw** property at Ulverscroft, and in this parish, into the **Roby** family.* Their daughter **Elizabeth**, for many years lived in Anstey with her brother, the late Mr. **Bradshaw Roby-Burgin**, who succeeded his brother to the **Burgin** name and property at Shardlow, co. Derby, and died here in 1850; Miss **E. Roby** herself died unmarried on 6th June, 1845, aged 72. She was buried at Aston, Derbyshire; where, inside the church, is a small mural tablet of marble to her memory, among several others to different members of the **Roby** family.

The second silver cup and the silver paten were bought for this church by subscription in 1880; the glass cruet being at the same time presented by the Rev. **W. S. Parker**, who was rector of this parish from 1879 to 1883. **Mr. Parker** succeeded his father as rector of Oxendon, Northants., in 1885.

BARROW-ON-SOAR.

(a)

SILVER CUP. Weight 8.18 oz. Height 6½ in. Diam. of bowl and of foot 3¾ in. Height of stem 2½ in. Date 1677. (PLATE 4.)

Hall marks. 1. Capital old English W in a plain shield. 2. Lion passant in a shaped oblong. 3. Leopard's head crowned in a shaped shield. 4. I. B. with a mullet below in a plain shield.

This cup has a nearly straight-sided bowl with a flat base. Its stem, which has no knob, swells out from the bowl into a plain foot, under which the lion passant is repeated.

(b)

SILVER PLATED PATEN. Length 9¼ in. Width 7½ in. Date circa 1800.

This paten is an oblong salver with the corners rounded off. Underneath are four round feet and this inscription: "*For the use of the church of Barrow upon Soar 1814. W. E., Vicar.*"

* For pedigree of Roby, see *Nichols*, Vol. iii., p. 784.

(c)

SILVER TWO-HANDLED PORRINGER WITH A COVER. Weight of porringer 10.8 oz. Height $4\frac{3}{8}$ in. Diam. at the top $4\frac{3}{4}$ in.; at the foot $2\frac{7}{8}$ in. Date 1697. (PLATE 4.)

Hall marks. 1. Court-hand B in plain shield. 2. Lion's head erased. 3. Britannia. 4. W with three pellets above and below.

This is a handsome straight-sided fluted porringer, originally a secular piece of plate, with two ornamental bands. Upon one side of it is this inscription, "*The gift of Mrs. Martha Uther, for the use of the sacrament, who erected the monument in the vestry in the parish church of Barrow upon Soar.*" Upon the opposite side of the porringer is placed this coat of arms; *Or, two bars Azure, each charged with as many bezants; Uther; impaling; Barry of six Argent and Sable a canton Ermine; Marshall.* Above the shield is an esquire's helmet on which is the crest of *Marshall; a demi man in armour proper beaver open holding in his dexter hand a truncheon, Or.**

Underneath the foot of the cup has been scratched "M. U."

SILVER COVER to the above porringer. Weight 6.8 oz. Diam. $5\frac{3}{8}$ in. Height $3\frac{3}{8}$ in. Date circa 1739. (PLATE 4.)

Marks. T. W. in script letters within a shaped oblong, repeated four times. Mark of *Thomas Whipham*, entered 1739.†

This cover, by a succession of plain round and hollow mouldings, slopes gradually up to the knob on the top. Its top-heaviness prevents it from matching very well with the more ancient porringer; its shape belonging rather to the cover of a large plain two-handed cup.

(d)

SILVER BASIN. Weight 12.4 oz. Diam. 8 in. Depth $1\frac{3}{8}$ in. Date either 1798, 1802, or 1809.

Hall marks. 1. Head of King **George III.** 2. Capital Roman C, G, or O in a plain shield, only half of this mark having been struck. 3. Leopard's head crowned in a rounded shield. 4. Lion passant in a plain oblong. 5. I. R. with a pellet between the letters, within an oblong; the mark of *John Robins*.

This basin, which is quite plain in shape, has the initials *M. F.* engraved underneath.

(b)

The donor of the silver plated paten was the Rev. **William Easton**, one time fellow of St. John's College, Cambridge, from whence he took the degree of B.A. in 1773, M.A. in 1776, and B.D. in 1784. This gentleman was instituted to the vicarage of Barrow on 12th Dec., 1794. In Aug. in the year following he married Miss **Susannah Atkinson**, a sister of the rector of Hillington, Norfolk. Mr. **Easton** was a liberal benefactor to the church in Barrow, spending more than £1000 upon the repairs of the vicarage house and buildings. He died, vicar of this parish, in the 80th year of his age, on 19th Jan., 1832. His wife, who was five years younger, survived her husband no longer than 11th of March following. Upon the east wall of the

* Crest of Uther as in Visit of London 1634, is "An arrow in fule Sable, headed and feathered Argent, to the shaft a pair of wings expanded Or." † "Gilda Aurifabrurum W. Chaffers," p. 187.

North transept in this church is a square white marble mural monument to the memory of Mr. **Easton** and his wife; upon which he is spoken of as one "who faithfully discharged every pastoral duty."

(c)

The porringer with its cover was given by **Martha Utber** in her life-time, as we learn from this extract referring to it in her will, made on 1st Feb., 1761, and proved at Leicester on 15th Feb., 1762: "*Whereas I did heretofore deliver into the hands of the vicar and churchwardens of the town of Barrow a large silver cup with the Utber and Marshall arms engraved thereon; now my mind and will is that the same shall be kept in the parish church of Barrow, and there used at all times for the celebration of the sacrament of the Lord's supper in the said church: but I desire that the sacrament money may not be received in the cover of the said cup as it has usually been.*"

This lady sprang from a family owning land for many years in this parish, in Sibley, and in Burton-on-the-Wolds, being the fourth daughter of **John Marshall**, of Barrow, gent., by **Margaret**, his wife.* She became the wife of Mr. **Thomas Utber**, of the city of Norwich, and bore him an only daughter, who, judging from her mother's will, married a **Kingston**. Mr. **Utber** died on 25th Sep., 1722, in his 72nd year, and was buried in the nave of Tacolneston church, Norfolk; his grave being marked by a slab on which are the arms of **Utber** impaling **Marshall**. After her husband's death Mrs. **Utber** seems to have returned to live in her native parish of Barrow. Here she died; and was buried in the south transept of the church on 30th Oct., 1761;† her age on her coffin being said to be 99. She had erected in 1745 her own monument, still to be seen on the West wall of this transept, in the upper part of which are the arms of **Utber** impaling **Marshall**, the former being tintured thus; *Gules two bars Or, each charged with as many torteaux*: in the inscription,‡ which describes the **Utber** and **Marshall** families as being "very ancient," and "both extinct in the male line;" her only daughter is also said to be buried there, but no name or date is mentioned.

In her will Mrs. **Utber** left £40 in trust with the vicar and wardens of Barrow and to her niece, **Ann Herrick**, only daughter of her nephew, **John Herrick**, late of Beaumont Leys,§ they to spend the interest in the repair of the monument, and to give any surplus at the end of every three years to her servant, **Ann Noble**, and to her heirs after her death. To **William Herrick**, son of **Thomas Herrick**, of Leicester, her amethyst ring. To "my granddaughter, Miss **Diana Kingston**," a ring. Legacies to tenants in the city of Norwich.

* Inscription on her monument. A gap exists in the parish registers between 1658 and 1689. Her baptism. and probably marriage also, took place within those years."

† Parish Register.

‡ For which see *Nichols*, Vol. iii., p. 75.

§ By Elizabeth, daughter of Samuel Marshall, brother of Mrs. Utber. || Nothing is now known of this trust

To poor of Barrow £5 in bread at her funeral. All houses and land both in Norwich and Barrow, with all plate and money, to **Ann Herrick**, whom she appointed sole executrix.

(d)

The initials "M. F." on the silver basin are probably those of the donor, of whom no certain clue can be traced.

GRIMSTON.

SILVER CUP. Weight 5.6 oz. Height 5 in. Diam. of the bowl $2\frac{7}{8}$ in.; of the foot $2\frac{3}{4}$ in. Height of stem 2 in. Date **1581.** (FIG. 4.)



Fig. 4. 1581. $\frac{2}{3}$ of full size. M. P. del.

Hall marks. 1. Capital Roman D in a plain shield. 2. Leopard's head crowned. 3. Lion passant; each of these two being within an outer shaped line. 4. R. W. in a plain shield.

This cup is a charming exception to the usual form of communion cups of this date. Its bowl is egg-shaped, with a raised moulding round the upper part; under which is an engraved band of foliage, divided into three parts by hour-glass curves. Near to the top of the stem is the knob, a large round moulding on a fillet, on which is engraved an oval ornament. Round the top of the foot is an engraved band of foliage; round its edge is the egg and tongue ornament in relief.

SILVER PATEN with a foot. Weight 2.3 oz. Diam. 4 in.; of the foot 2 in. Height of foot 1 in. Date *circa* **1581.**

No marks.

To all appearance this paten is of the same date as the cup, although it does not form a cover to it, neither does it fit on to the cup very well with the foot downwards. It has a flat edge $\frac{1}{4}$ in. wide, the middle part being sunk in a shallow round. The foot is a disk attached to the paten by a stem which swells a little towards the foot, and more towards the paten.

The family of **Brooksby** was the principal one here in 1581.

WARTNABY.

SILVER CUP. Weight 3.5 oz. Height $5\frac{1}{4}$ in. Diam. of the bowl $2\frac{3}{4}$ in.; of the foot $2\frac{5}{8}$ in. Height of stem $2\frac{1}{2}$ in. Date *circa* 1570. (PLATE 5.)

One mark only. The leopard's face within a shaped shield.

This little cup has a narrow bowl straight-sided in its lower part, swelling out higher up into a bell-shaped lip. Its stem is a narrow and evenly balanced one, and differs from all the other cups of this "leopard's face" series in being divided in half by a large round knob from which it swells out to both ends: at its upper end is a narrow vertical edge, its lower end is without this edge, which has apparently been taken out at some time when the cup has been repaired. The foot is rounded off into a flat edge.

PEWTER FLAGON. Height $5\frac{3}{4}$ in. Diam. at the top $3\frac{5}{8}$ in.; at the foot 4 in. (PLATE 5.)

Marks. 1. X crowned. 2. Four small shapes containing; a lion rampant: possibly a buckle: illegible mark: leopard's face. 3. On the bottom inside, "W. H.," a rose and thistle below.

This is a small tankard, straight-sided in shape.

TWO PEWTER PLATES. Diam. of each $9\frac{1}{4}$ in.

Marks. 1. X crowned. 2. Out of a ducal crown an eagle rising towards the sun in splendour. 2. "London" in an oblong. 3. In four small shapes; "B. and V.;" sun in splendour; eagle's head erased; per chevron engrailed three eagles' heads erased.

HATHERN.

SILVER CUP. Weight 13.8 oz. Height 9 in. Diam. of bowl $4\frac{5}{8}$ in.; of foot $5\frac{1}{4}$ in. Height of stem $6\frac{1}{4}$ in. Date 1861.

Birmingham hall marks.

This is an imitation mediæval cup having round the bowl this inscription: "*Ex dono Doæ Mariæ Phillipps de Garenton in Com: Leicester, 1698.*" Beneath which there is an engraved ornament of vine leaves. There is a band of trefoil ornament round the foot.

SILVER PATEN. Weight 4.7 oz. Diam. $6\frac{5}{8}$ in. Date 1861.

Birmingham hall marks.

In the centre of this paten there is a cross within a quatrefoil, and round the edge a trefoil ornament.

SILVER ELECTRO-PLATED FLAGON. Height $12\frac{1}{2}$ in. Diam. of top $3\frac{1}{4}$ in.; of foot $4\frac{1}{8}$ in.

This is a jug-shaped flagon having in front a cross crowned, and on either side the sacred monogram crowned.

In the terrier for 1708 the church plate then here is thus described; "A large silver cup, two large flagons of the best pewter, two salvers of the same; all the gift of Dame Mary Phillipps, wife of Sir Ambrose Phillipps, of Garenton. The cup weighs about 19 oz."*

* See Sheepshed.

At the time when the church was restored, in 1861, the cup was melted down and manufactured into the present cup and paten at the expense of the rector. The pewter vessels were sold and the plated flagon bought.

KEGWORTH.

SILVER PLATED CUP. Height $8\frac{5}{8}$ in. Diam. of bowl and of foot $3\frac{1}{4}$ in. Height of stem $4\frac{5}{8}$ in.

The bowl of this cup is straight-sided in shape. The stem is narrow, with a small moulding for knob. Both bowl, stem, and foot are fluted.

SILVER PLATED PATEN. Diam. $9\frac{1}{2}$ in.

This paten is hexagonal in shape, having the sacred monogram in the centre.

SILVER PLATED DISH with foot. Diam. $9\frac{1}{8}$ in. Height of foot $5\frac{3}{4}$ in.

This dish corresponds with the paten.

SILVER PLATED FLAGON. Height $12\frac{3}{4}$ in. Diam. at top $3\frac{7}{8}$ in. Diam. of foot $6\frac{1}{2}$ in.

This is a straight-sided flagon with a spout at the top. The sacred monogram is on one side of the drum.

In the terrier of 1745 the church plate here is thus recorded; "A silver cup with a cover, of small weight. Two pewter flagons; a salver." These pieces were sold when the present service was procured in 1854.

ISLEY WALTON.

SILVER CUP. Weight 5.2 oz. Height $5\frac{3}{8}$ in. Diam. of bowl $3\frac{1}{4}$ in.; of foot 3 in. Height of stem $2\frac{3}{4}$ in. Date *circa* 1575. (PLATE 4.)

No hall marks.

This pretty little cup has a short bowl shaped into an inverted truncated cone having round its upper part a band of stroke ornament divided into six parts by hour-glass curves. It has something of a baluster or urned-shaped stem with a projecting disk in its upper part divided into several parts by radii, a similar wider disk being placed underneath the stem. The foot is of the usual shape. This cup was made probably by the maker using the "rose" as his mark, for in several points it is very similar in shape to the cup so marked at Nailstone.

PEWTER DISH. Diam. 9 in.

Marks. 1. Rose crowned, with an illegible name round it. 2. "London."

PEWTER DISH. Diam. 9 in.

Marks. 1. Rose crowned, with an illegible name round it. 2. "London." 3. Apparently a lily rising from a lattice work.

SMALL PEWTER FLAGON. Height $8\frac{1}{4}$ in. Diam. of top $3\frac{1}{2}$ in. Diam. of foot $4\frac{1}{4}$ in.

Marks. Lion's face in an oblong, repeated four times.

This is a straight-sided flagon narrowing towards the top with a flat top to its lid.

LONG WHATTON.

SILVER CUP. Weight 19.1 oz. Height $8\frac{3}{8}$ in. Diam. of bowl $4\frac{3}{8}$ in.; of foot $5\frac{7}{8}$ in. Height of stem $5\frac{1}{2}$ in. Date 1850.

Birmingham hall marks.

The bowl of this cup is an inverted truncated cone, with this inscription round it: "*Calicem salutaris accipiam et nomen Domini invocabo.*" The stem, knob and foot are hexagonal in shape; the whole piece is much ornamented with embossed and engraved foliage.

SILVER PATEN, parcel gilt. Weight 4.8 oz. Diam. $6\frac{1}{8}$ in. Date 1850.

Birmingham hall marks.

This is a plain-shaped paten, the whole of its upper surface being gilt; in the centre is a cross within a quatrefoil.

SILVER FLAGON. Weight 20.7 oz. Height $10\frac{1}{2}$ in. Diam. of top $2\frac{5}{8}$ in.; of foot $3\frac{3}{4}$ in. Date 1850.

Birmingham hall marks.

This is a plain jug-shaped flagon, with a cross engraved in front.

SILVER DISH. Weight 8.7 oz. Diam. $7\frac{1}{8}$ in. Date 1846.

London hall marks.

This is a plain dish with its centre sunk in a six-lobed depression. Round its edge is "*Agnus Dei qui tollis peccata mundi da nobis tuam facem.*"

TWO PEWTER PLATES. Diam. $9\frac{7}{8}$ in.

Marks. 1. X crowned. 2. C. T. M. each letter being crowned. 3. These arms: Two bars between three dexter hands; above, a helmet surmounted by a dexter hand for a crest; around the arms, "*Thomas Scattergood.*"

According to Archdeacon **Bonney**, the communion service here in 1832 consisted of a silver plated cup, paten and flagon, with two pewter plates.

The present communion service was one of several gifts made to this church by the late **Edward Dawson**, Esq. This gentleman was the representative of a family which has for several generations owned land in this parish. He was the eldest son of **Edward Dawson**, Esq., of Long Whatton, by his wife **Susan**, eldest daughter of **Thomas March Phillipps**, Esq., of Garendon Park, and was born on 14th March, 1802. Mr. **Dawson** was M.P. for South Leicestershire from 1832-1834, and high sheriff of the county in 1839. He married first on the 22nd July, 1828, **Mary Finch**, eldest daughter and co-heir of **John Finch Simpson**, Esq., of Launde Abbey, which estate was brought to him by his wife, who died on 21st March, 1843.

He married secondly in Feb., 1847, **Annie Forbes**, eldest daughter of **John Stewart**, Esq., of Belladrum, co. Inverness, who died on 14th Oct., 1874. Mr. **Dawson** died on 1st June, 1859, having had issue by both his wives; his eldest son, **Edward Finch Dawson**, Esq., being the present owner of Launde Abbey and of the old estate of the family at Long Whatton. Before making this gift, Mr. **Dawson** had taken the principal share in restoring the chancel of this church in 1845; he also built two years later a capital national school with a school house.

LOUGHBOROUGH. ALL SAINTS'.

(a)

SILVER CUP WITH COVER PATEN. Weight of cup 13.7 oz. Height $8\frac{1}{2}$ in. Diam. of bowl $4\frac{1}{4}$ in., of foot $4\frac{3}{8}$ in. Height of stem $3\frac{3}{4}$ in. Date *circa* 1610. (PLATE 7.)

No marks.

The bowl of this cup is nearly straight-sided in shape, with a bell-shaped lip; round its lip is an engraved band formed with two straps enclosing a scroll of pomegranates, figs, and flowers. A similar band is repeated lower down; beneath which is this inscription; "*d. d. Robertus Chichester Devoniensis 1862.*" The stem is evenly balanced, with a wide moulded knob. Round the top of the foot is engraved a wreath of laurel leaves; and round the edge is the egg and tongue ornament. Underneath the foot is this weight, 13 oz. 15 dwts.

SILVER COVER PATEN with foot. Weight 4.7 oz. Diam. $4\frac{3}{8}$ in. Diam. of foot $1\frac{7}{8}$ in. Height of foot $1\frac{1}{2}$ in. (PLATE 7.)

No marks.

This cover paten is quite plain in shape with the usual projecting rim inside, and the weight 4 oz. 15 dwt. engraved on the inside. This cup, with its cover, has evidently belonged formerly to some other church.

(b)

TWO SILVER PLATED CUPS. Height $8\frac{3}{8}$ in. Diam. of bowl $4\frac{3}{4}$ in., of foot $4\frac{3}{8}$ in. Height of stem $5\frac{1}{2}$ in.

The bowl of each of these cups is in shape an inverted truncated cone. In front is the sacred monogram within a circle of glory. Their stems have large knobs. Round the edge of their feet, which are hexagonal in shape, there is this inscription; "*Ex dono Henrici Fearon Rectoris 1857.*"

SILVER PLATED PATEN with foot. Diam. 9 in. Diam. of foot $4\frac{7}{8}$ in. Height of foot $2\frac{7}{8}$ in.

This paten, which, with its foot, is hexagonal in shape, has this inscription round the edge of the foot; "*Ex dono Henrici Fearon Rectoris 1870.*"

SILVER PLATED FLAGON. Height 14 in. Diam. of top $3\frac{3}{4}$ in., of foot $5\frac{3}{4}$ in.

This flagon is straight-sided in shape, with a spout at the top, and a cross for a knob on the lid. Round the edge there is the same inscription as the one on the paten.

The churchwardens' accounts of this parish, which extend from 1583 to 1691 and from 1742 to 1797, contain the following entries relating to communion plate formerly here :—

" 1619. An Inventorye of such goods as doe now belong unto the church."
"7. A Communion Cupp of silver with a cover."*

" 1620. Delivered up all the particular goods of the church specified in the former inventory & moreover one book of the King's entituled A defence of the right of Kings & also two great pewter flagons for the communion."

	£	s.	d.
" 1639. Item payd for ye flagone for ye communion table	2	7	0"†
Item pyd to Tho. Rayne for bringing downe ye flagone from London		2	0"
" 1657. Paid to Ayer of Leic' for a flaggon & 2 pewter dishes	17	4	"
" 1658. Paid for a quart of Sacke to drink with Mr. Sheffield when wee received the Silver bowle Mrs. Davenport gave to the church.....		2	0"
" 1752. P ^d for 2 Baskitts for ye communion plate	4	0	"

None of the above mentioned pieces were here in 1781, when a terrier was made and the communion plate described therein as follows; "Two silver flagons thus inscribed, '*D. Willson*'; weight of one 5 lbs. 14 oz.; weight of the other 5 lbs. 12 oz. Two silver salvers; weight 3 lbs.; this inscription on each, '*D.W.*' Two silver plates, this inscription on each, '*D.D. Edwardus Butler, L.L.D. 1727.*' Two silver cups with covers, one with this inscription, '*Ex dono Johannis Oldershaw,*' weight 13 oz.; one with this inscription, '*Ex dono Barthol: Hickling,*' weight 14 oz." Soon after that terrier was made this service was increased by the gift of a large salver resting on claw feet, bequeathed by Mrs. Alt.

The whole of this valuable service of communion plate was stolen out of the church in the night of Wednesday, 6th May, 1857; no portion of it was recovered. It was kept in a chest in the "evidence chamber" over the south porch.

The silver cup, once here, the gift of Mrs. Davenport, was provided in accordance with this clause in that lady's will, made 12th June, 1656, and proved P.C.C. 24th June, 1657; "*First I bequeth unto the churchwardens for the time being, and to their successors, of the parish church of Loughborough, to be used in the blessed Sacrament of the Lord's Supper in the church of Loughborough aforesaid, one silver bowl.*"

The donor was Elizabeth Bambrige, and became the wife of John Davenport, of Burleigh Park, Loughborough, to whom she bore a daughter,

* For list of other goods see "Chapters in the *History of Loughborough*," Rev. W. G. D. Fletcher, p. 25.

† Could hardly have been of silver.

Elizabeth, buried at Loughborough on 5th Dec., 1614,* and a son **Henry**, baptized here on 30th April, 1617.* In 1630 Mr. **Davenport** was returned to the commissioners for knighthood.†

In his will, dated 4th Oct., 1645 and proved P.C.C. 3rd Feb., 1646, **John Davenport**, "of Burley Parke Esqre," left to his sister **Mary Lee**, £20 a year for life: to his servant **Robert Melborne** £40: all the rest of his "goods and chattels" to his wife **Elizabeth**, his sole executrix.

After her husband's death **Elizabeth Davenport** lived at Loughborough, where she was buried, leaving no surviving issue, on 13th May, 1657.*

In her will, **Elizabeth Davenport** "of Loughborough, widow," left to the poor of Loughborough £5: to her brother **Robert Bambrige** £10 a year for that term of years in which Sir **George Villiers**, Bart., pays £50 a year to her estate: to sister **Marie Lee** £10 a year out of same sum: to **Josuah Bambrige**, son of her brother **George**, dead, £20 out of same sum: rest of that £50 a year to be divided amongst youngest children of **George Bambrige** and their mother: to **Josuah Bambrige** message "wherein I now dwell" bought of Mrs. **Marie Hughes**: to kinsman **William Sheffield**‡ rector of Ibstock one silver bowl: to "my niece" **Elizabeth** wife of said cousin **W. Sheffield** one great silver salt: to niece **Marie Bambrige** £100 and one big silver tankard: to cousin **Thomas Alsopp** of Hatherne "my silver watch."

D. Willson, the donor of the two silver flagons and two salvers formerly here, was **Dorothy**, 9th child of Sir **Anthony Chester**, Bart., and second wife of **John Willson**, of Knight-thorpe, a hamlet of this parish.§ She was doubly connected with this place since she was elder sister of **Penelope**, second wife of **John Alleyne**, B.D., rector of Loughborough from 1696 to 1739.¶

Edward Butler, D.C.L., the donor, in 1727, of the two plates formerly here, was the son of **Robert Butler**, of London, gent., and was born in 1687. He matriculated at Magdalen College, Oxford, on 13th Oct., 1703, from whence he took his B.A. degree on 27th May, 1706, and M.A. on 13th May, 1709. He was elected President of the College in 1722, and was granted the degree of D.C.L. on the 22nd of June in the same year. In 1737 he was elected M.P. for the University, which he continued to represent, retaining also the presidency of his college, until his death on 29th Oct., 1745. Dr. **Butler** became connected with Loughborough through his marriage with **Mary**, daughter of **Anthony Tate**, whose elder brother **Henry Tate** had bought Burleigh Park, Loughborough, in 1696; to which property Mrs. **Butler**, on the death of **Henry Tate's** only son **William** on 30th Dec., 1722,

* Parish Register.

† M.S. Carte 78, fo. 19.

‡ Married to Elizabeth Bambrige, at Loughborough, 16th March, 1651-2. Parish Register.

§ For further notice of her, see Tugby.

¶ For some account of Knight-thorpe, Burleigh and Loughborough Parks, see *Handbook of Loughborough*, by Rev. W. G. D. Fletcher, F.S.A., p. 45.

succeeded.* Mrs. **Butler** died on 15th July, 1730, aged 40. She bore Dr. **Butler**, an only daughter and heiress, **Mary**, married first to **Philip Herbert**, of Kingsey, co. Oxford, M.P., and secondly to **Benjamin Tate** her relative. In Magdalen College Chapel there is a monument to the memory of Dr. **Edward Butler** and his wife, bearing a long Latin inscription,† and these arms; *Or on a chief indented Azure, three covered cups of the field; Butler; impaling per fess Or and Gules, a pale counterchanged, three Cornish choughs proper; Tate.*

It is doubtful which **John Oldershaw** presented the cup and cover named in the above inventory. The one most likely to have made that gift was the son of **Peter Oldershaw**, of Kegworth, by **Ursula**, daughter and co-heir of **William Fettiplace** 4th son of Sir **Edmund Fettiplace**, Kt., which **John** was baptized on 29th Aug., 1655. He married at Marston on 13th July, 1682, **Sarah**, daughter and co-heir of **John Fowler**, of Loughborough, mercer, who by his will dated 25th Nov., 1680, and proved P.C.C. on 9th March, 1681-2 left his daughter, **Sarah**, Loughborough Old Parks. **John Oldershaw**, an attorney by profession, was buried at Loughborough on 10th Feb., 1726-7,‡ and his wife **Sarah**, on 25th May, 1723.‡

The other **John Oldershaw** who may have made the gift, was the eldest son of the above **John** and **Sarah**, and was baptized at Loughborough on 11th June, 1683.‡ He married **Elizabeth**, 4th daughter of the Rev. **John Davys**, rector of West Leake, co. Notts., which lady was buried at Loughborough, on 25th Dec., 1723;‡ he himself being buried here on 9th Nov., 1728.‡

By his will, made 23rd Dec., 1727, and proved in Leicester, 22nd Nov. 1728, **John Oldershaw**, "apothecary of Loughborough," left to **Samuel Martin**, of Loughborough, clerk, **John Boyer** and **John Alt** in trust, land in Loughborough Parks and all his personality for the benefit of his daughters and youngest son; **Parnell**, **Elizabeth**, **Dorothy**, and **James**. Seal "*Azure three annulets Or;*" arms of Oldershaw.

Upon the north wall of the north aisle of this church, is a marble tablet commemorating both father and son and several later members of this family.

It is also a matter of doubt as to which **Bartholomew Hickling** presented the other cup and cover formerly here. It was most probably the gift of the founder of the free school for girls. This **Bartholomew Hickling** was the son of **Thomas Hickling** and was baptized here on 28th March, 1619.‡ He was married before **W. Danvers**, J.P., on 23rd Aug., 1655, to **Jane Clarke**, widow, of Loughborough,‡ by whom he had a son **Bartholomew**, born on 12th May, 1656, and buried here on 16th Dec., 1674.‡ **Bartholomew**

* Henry, son of Mr. Anthony Tate, born 10th March, 1653. Anthony, son of Anthony Tate, gent. and Bridget, bap. 5th April, 1661. Sutton Bonnington Register.

† For which see *Nichols*, Vol. iii. p. 909.

‡ Parish Register.

Hickling died without surviving issue and was buried here on 30th June, 1688;* his widow being buried on 30th Sep., 1690.*

By his will, made 4th June 1683 and proved in Leicester on 6th Aug. 1688, **Bartholomew Hickling**, "of Loughborough yeoman," left to his wife for life two closes in Loughborough Park bought by his late brother **John Hickling** of **Joseph Dawson** draper of London; also half a yard land bought by himself of "cousin **John Hickling** of Loughborough;" charged with the payment of £10 a year towards teaching and clothing twenty poor girls. After wife's death same land to be handed over to trustees who shall devote the income to the same school. That body also to administer the land left for charitable purpose by his brother **John**. To same trustees half a yard land in Loughborough they to spend the income in providing Bibles for a certain number of children in Leicester, Loughborough, Mountsorrel, Woodhouse, Rothley, Quorndon, Barrow, Sibley, Seagrave, Walton, Burton, Hathern, Sheepshed, Belton, and also in Rempston, Sutton Bonnington, and Nomanton-on-Soar co. Notts. To another body of trustees he left certain cottages in Swan Street, Loughborough, for the benefit of the poor in this town, as they think fit. To his wife for life certain land in Rothley and after her death to trustees for a free school in Rothley for fourteen or fifteen boys. Several legacies to kinsmen. To be buried in Loughborough church in or near grave of son. Wife, **Jane**, sole executrix.†

The salver formerly here was bequeathed by Mrs. **Alt** in the following clause of her will, made 29th July, 1769, and proved in Leicester on 27th Oct., 1783, "*I do will order and direct that my executrix do within three months after my decease lay out the sum of £50 in the purchase of a piece of silver plate for the purpose of setting the flagons upon at the celebration of the Sacrament of the Lord's Supper in the parish church of Loughborough aforesaid and to be used with the communion plate of the said parish church for which purpose I give the same for ever.*"

This lady was **Ann**, the daughter of **George Hutchinson** of Loughborough, and was baptized here on 26th Dec., 1695.* She married at Walton-le-Wolds, co. Leicester, on 13th April, 1721,‡ Mr. **John Alt**, a small proprietor owning land at Garendon and Blaby, co. Leicester, who died on 22nd Dec., 1732, aged 59. His widow survived her husband till 8th Aug., 1783, when she died at the age of 87. They were both buried in Sheepshed church; on the south wall of which is a white marble tablet to the memory of them and their children **John** and **Catherine**, erected at the cost of £30 left by Mrs. **Alt** for that purpose, on which are the arms of **Alt**; "*Quarterly Gules and Argent within a bordure of annulets and crosses pattée alternately counterchanged.*" Mrs. **Alt** bequeathed £50 to the poor of Loughborough. All her real and personal estate she left in trust for the benefit of her only surviving child **Ann** the wife of **Thomas Borrow**, recorder of Derby, of Castlefields, in St. Peter's, Derby: which lady she appointed her

* Parish Register. † For further particulars of these charities see *Reports of the Parliamentary Commissioners*. Vol. xvii. 1836, pp. 393 and 412. ‡ Parish Register.

sole executrix. From **Thomas** and **Ann Borrow** is descended **J. C. Burton Borough, Esq.**, of Hulland Hall, co. Derby, and Chetwynd Park, co. Salop.

(a)

Robert Chichester, Esq., the donor of the silver cup and paten now here, was the representative of a branch of the ancient family of **Chichester**, of Raleigh, Devon, being the direct descendant of **Richard**, the second son of **Richard Chichester**, of Raleigh, by his wife **Alice**, daughter and heir of **John Wotton**. **Richard Chichester**, the younger, by his marriage, *temp.* **Edward IV.**, with **Thomasyne**, daughter and heir of **Symon Halle**, of Halle, Devon, became possessed of the estate of Hall; from him have sprung many generations of **Chichesters** of Hall.* The late **Mr. Robert Chichester** was the eldest son of **Charles Chichester**, of Hall, by **Henrietta**, seventh daughter of **P. Inledon Webber**, of Buckland House, Devon, and was born on 13th March, 1804. From early life **Mr. Chichester** was an enthusiastic lover of church bells, of which he had a considerable practical knowledge. He had an excellent ear for the tune and tone of bells, and was himself a good ringer, though not deeply versed in the mysteries of change ringing, an art unknown in his native county in the days of his youth. When an undergraduate at Oxford in 1823, he made the acquaintance of **Mr. William Taylor**, bell founder of that city, and employed him in making the treble bell and in recasting the fourth and tenor bells of his parish church of Bishop's Tawton. The treble and third bells were recast in 1853 by **Mr. John Taylor**, of Loughborough, **Mr. Chichester** bearing the chief cost. Owing to his love for campanology, he paid various visits to the eminent firm of bell founders at Loughborough, Messrs. **Taylor** and Co., and so became interested in All Saints' church and sympathized with it in its loss of communion plate. It was upon one of those visits that he surprised the late vicar with the question, "would you like a cup?" and, in answer to his prompt response in the affirmative, handed him over this one, which he had bought from a silversmith at Exeter. **Mr. Chichester**, who was a J.P. and D.L. of his native county, died 19th August, 1882, and was buried at Bishop's Tawton. He married, 14th Dec., 1826, at All Souls' church, Langham Place, London, **Clarentia**, only child of **Col. Henry Mason, E.I.C.S.**, of Chichester, Sussex, by whom he had five sons and four daughters, his eldest son **Charles Chichester, Esq.**, being the present owner of Hall. **Mrs. Chichester** was born on Christmas Day, 1804, and died on 21st Sep., 1878; a painted window to the memory of herself and her husband has been placed in Tawton church. The **Chichesters** of Hall bear these arms; *Chequey Or and Gules, a chief vairé. Crest: a heron rising with an eel in the beak proper.*

* For pedigree, see *Burke's Landed Gentry*.

(b)

The Ven. **Henry Fearon**, B.D., was the son of the Rev. **Joseph Francis Fearon**, Vicar of Cuckfield, and Prebendary of Chichester, by his wife **Jane**, the daughter of **William Clutton**, Esq., of Ockenden, co. Sussex, and was born at Cuckfield on 20th June, 1802. He was sent to Winchester School, and there gained a gold medal offered by **George IV.**, in 1820, for Latin Hexameters, the subject being "*Georgius Quartus Solium Paternum Ascendit.*" Mr. **Fearon** entered at Emmanuel College, Cambridge, from whence he took his B.A. degree in 1824, M.A. in 1827, and B.D. in 1834. He was ordained deacon by the Bishop of Chichester in 1826, and priest in 1827. He was elected a fellow of his college in 1827, and vacated his fellowship for the rectory of Loughborough in 1848, and was made an honorary canon of Peterborough cathedral in the year following. Upon the death, in 1863, of **T. K. Bonney**, Archdeacon of Leicester, the Rev. **H. Fearon** was appointed his successor. Both in the county as archdeacon and in his parish as rector, **Henry Fearon** was greatly beloved. He was one of the kindest hearted of men and one of the most humble. Under his influence, which could always be reckoned upon in the carrying out of any good work, large sums were contributed towards the restoration of Loughborough parish church, which was finally completed at the cost of close upon £10,000.

The Archdeacon died unmarried, at his rectory, on the 12th June, 1885, not many months after he had resigned the archdeaconry. He was buried in Loughborough cemetery on the 19th, in the North West corner, by the side of his sister, Miss **Sarah Fearon**; a headstone, surmounted by a cross within a circle, marks his grave, in the inscription of which it is said that "it was his happiness to live and to work for the welfare of those around him."

Within the chancel of this church his parishioners have placed a brass to the memory of their "faithful and loving pastor," "gentle, tolerant, and courteous;" in the upper part of which is a representation of the Archdeacon's seal, shewing these arms; *Gules, a cinquefoil Ermine*; Borough of Leicester; *impaling*; *Gules, a chevron between three horse shoes Or*; **Fearon**. The church also possesses another memorial of its late rector in a handsome brass eagle lectern, presented by his nieces, the Misses **Erle**, of Torquay.

LOUGHBOROUGH. EMMANUEL CHURCH.

SILVER CUP. Weight 10.6 oz. Height $7\frac{7}{8}$ in. Diam. of bowl $3\frac{7}{8}$ in.; of foot $3\frac{5}{8}$ in. Height of stem $4\frac{1}{4}$ in. Date 1837.

London hall marks.

The bowl of this cup is straight-sided, slightly bell-shaped. In front is the sacred monogram, with a cross above and three nails below, within a circle of glory. It has a baluster stem and a plain, round foot, on the edge of which there is this inscription: "*Ex dono Rev. T. Thorp Wilfordiæ Rectoris 1837.*"

SILVER CUP. Weight 9.6 oz.

In every other respect the same as the first.

SILVER FLAGON. Weight 28 oz. Height 11 $\frac{1}{4}$ in. Diam. of top 3 $\frac{3}{4}$ in.; of foot 5 $\frac{3}{8}$ in. Date 1837.

London hall marks.

This flagon is straight-sided in shape, with a round top to its lid, which is surmounted with a flame-shaped knob. On the drum is the sacred monogram, and round the edge of the foot the same inscription as that on the cups.

SILVER PATEN. Weight 11.7 oz. Diam. 8 $\frac{1}{2}$ in. Date 1837.

London hall marks.

This paten is quite plain in shape. It has the sacred monogram and the same inscription in the centre as that on the cups.

SILVER PATEN. Weight 12.3 oz. Diam. 8 $\frac{1}{2}$ in. Date 1860.

London hall marks.

This newer paten is plain in shape like the first, and it has the sacred monogram in the centre, and also the same inscription, with the exception of the date "1860," instead of "1837."

This communion plate is plain and solid in character, and is a good example of the style of church plate made in the beginning of this century. It was presented to this church on the day of its consecration, 6th Sep., in the first year of the reign of Her Majesty Queen Victoria; the funds for the building of the church having been raised principally through the exertions of the Rev. W. Holme, B.D., the then rector of All Saints'.

The Rev. Thomas Thorp, the donor of this service, was a native of Loughborough, being the great nephew of Thomas Thorp, one of the founders of the Loughborough bank. He was the son of John Thorp, surgeon and banker of this town, and D.L. for the county of Leicester, by Elizabeth, daughter of William Pochin, attorney, of Loughborough, and was baptized at All Saints' on 16th Nov., 1790.* He entered Emmanuel College, Cambridge, and from thence took his B.A. degree in 1813 and M.A. in 1816. Soon after the latter date he was appointed to the rectory of Wilford, co. Notts, which he held for forty-six years, dying in that parish, unmarried, on 25th Feb., 1864.

LOUGHBOROUGH. HOLY TRINITY.

SILVER PLATED CUP. Height 7 $\frac{3}{8}$ in. Diam. of bowl 3 $\frac{3}{8}$ in.; of foot 4 $\frac{3}{8}$ in. Height of stem 4 $\frac{7}{8}$ in.

The bowl of this cup is in shape an inverted truncated cone. There is a large knob to the stem, and a trefoil ornament round the foot.

* Parish Register.

SILVER PLATED CUP.

Exactly the same as the first, with the exception of being slightly smaller.

SILVER PLATED PATEN with foot. Diam. $6\frac{1}{2}$ in. Diam. of foot $3\frac{7}{8}$ in. Height of foot $1\frac{5}{8}$ in.

This is a plain-shaped paten with a cross in the centre.

SILVER PLATED FLAGON. Height $11\frac{1}{2}$ in. Diam. of top $2\frac{1}{2}$ in.; of foot $3\frac{3}{4}$ in.

This flagon is jug-shaped, with a cross for a knob, on the top of the lid.

SILVER PLATED ALMS DISH. Diam. 15 in.

This is a plain dish, having in its centre a cross, and round its edge this text; "*It is more blessed to give than to receive.*"

Holy Trinity church was consecrated 8th Oct., 1878, at which time it was presented with this service of communion plate by Mrs. **Maria White**,* the second wife of Mr. **Edwin Parkinson White**, of "The Grove," Loughborough, which gentleman died on 8th July, 1887, aged fifty-eight. Mr. **White**, who was churchwarden of All Saints' for many years, was a much respected partner of the firm of **Cartwright and Warner**, of this place.

MOUNTSORREL. CHRIST CHURCH.

SILVER CUP. Weight 10 oz. Height $7\frac{3}{8}$ in. Diam. of the bowl and of the foot $3\frac{5}{8}$ in. Height of stem 4 in. Date **1843**.

London hall marks.

This cup has a straight-sided bowl, swelling out into a bell-shaped lip, and rounded off below, standing on a round stem swelling out in the middle into a knob. Round the edge of a plain foot is this inscription; "*Mountsorrel Church, A.D. 1844.*"

SILVER CUP. Weight 9.7 oz.

Same as the other.

SILVER PATEN with a foot. Weight 13.6 oz. Diam. 8 in. Diam. of the foot $3\frac{1}{2}$ in. Height of foot 2 in. Date **1843**.

London hall marks.

This is a plain-shaped paten, having in its centre the sacred monogram with a cross and three nails within a circle of glory.

SILVER FLAGON. Weight 33.1 oz. Height 14 in. Diam. at the top $3\frac{3}{4}$ in.; at the foot $5\frac{1}{2}$ in. Date **1838**.

London hall marks.

This is a straight-sided flagon, narrowing to the top. Its lid is surmounted with a flame-shaped knob. Its handle is R shaped. There is the same inscription on this as on the other pieces.

This service of communion plate was presented to Christ Church,

* Daughter of Mr. James Cross, of Nottingham.

Mountsorrel, by the foundress, Miss **Sarah Brinton**, on the day of its consecration in 1844.

The history of the church is shortly this; Miss **Brinton** wishing, in her desire to do good, to build a church in some populous neighbourhood, consulted her friend the late Canon **John Babington**, rector of Cossington, who advised her to build this one in Mountsorrel. This lady was the only daughter of **William Brinton, Esq.**, of Antigua, and was born on the 21st July, 1790. Her father was a merchant and one of the principal inhabitants of Antigua, where he lived for nearly fifty years; returning to his native land in about 1814, he settled in a house which he rented in the parish of Speen, co. Berks., where he died on 31st Oct., 1823, aged 74: he was buried in Speen church, in which, near to his grave, his daughter placed a mural monument of marble to his memory, bearing a medallion portrait of him by Sir **F. Chantrey**; and an inscription in which she is spoken of as his "sole surviving relative." Miss **Brinton** after her father's death first continued to live at Speen and then took up her abode with different friends. She died on 23rd June, 1865, and was buried in Speen churchyard, a short inscription to her memory being placed on her father's monument. In addition to building this church at Mountsorrel, Miss **Brinton** built the vicarage house and endowed the living with twenty acres of land; she also bequeathed £40 a year towards an organist's salary, the Sunday school, and the relief of the poor in this parish. The advowson of the church she gave in her life-time to the late Rev. **C. Kemble**, whose widow is the present owner of it. To the vicar of Speen this charitable lady left £400, the interest of which she ordered to be given by him to the poor of that parish at "his absolute discretion."

MOUNTSORREL. ST. PETER'S.

SILVER CUP AND COVER PATEN. Weight of cup 5.3 oz. Height 7 in. Diam. of bowl $3\frac{1}{2}$ in.; of foot $2\frac{7}{8}$ in. Height of stem $3\frac{3}{8}$ in. Date 1574. (PLATE 5.)

No hall marks.

This cup, a rather peculiar shaped one, has a deep narrow bowl, straight-sided in the lower part, swelling out at the lip; round its middle is a band of foliage divided into three parts. The stem is a tall straight evenly balanced one, divided in half by a large round knob between two narrow bands of much worn ornament. The foot, which is rounded off into a flat edge, has round its top two plain straps enclosing three rows of little horizontal strokes.

SILVER COVER PATEN with a foot. Weight 1.8 oz. Diam. $3\frac{1}{2}$ in. Diam. of foot $1\frac{1}{4}$ in. Height of foot $\frac{3}{8}$ in. Date 1574. (PLATE 5.)

On this cover there seems to be a trace of a maker's mark, possibly a conventional flower. Round the top of the cover is a band similar to the one round the cup. On the foot, which is much battered, is the date 1574, the second numeral being much defaced.

SILVER CUP. Weight 4.7 oz. Height $5\frac{1}{4}$ in. Diam. of bowl 3 in.; of foot $2\frac{3}{8}$ in. Height of stem $2\frac{1}{4}$ in. Date 1807.

Sheffield hall marks.

This cup has a bowl shaped into an inverted truncated cone with a flat base; on its side is the sacred monogram. The stem is a narrow round one, swelling out a little to the bowl and into a plain round foot.

SILVER PLATED COVER PATEN with a foot. Diam. $3\frac{1}{2}$ in. Diam. of the foot and Height $\frac{7}{8}$ in.

This is a plain cover plated on copper, having formerly no doubt belonged to another and rather larger cup.

SILVER PATEN with a foot. Weight 3.2 oz. Diam. $4\frac{3}{4}$ in. Diam. of foot $1\frac{3}{4}$ in. Height of foot 1 in. Date *circa* 1735.

Hall marks obliterated.

This Paten, which formerly belonged to some other church, has a flat moulded edge, from which the middle part is sunk flat $\frac{1}{8}$ of an inch deep. The foot is a disk attached to the paten by a stem swelling out at both ends.

SILVER PLATED FLAGON. Height $9\frac{3}{4}$ in. Diam. at the top $2\frac{1}{8}$ in.; at the foot $3\frac{3}{8}$ in.

This is a jug-shaped flagon with flattened sides; on one side is the sacred monogram, on the other a cross patée.

TWO SILVER PLATED PATENS. Diam. of each $6\frac{1}{4}$ in.

These are plain flat patens each with a cross in the centre.

PEWTER FLAGON. Height $9\frac{1}{2}$ in. Diam. at the top 4 in.; at the foot $5\frac{5}{8}$ in.

Marks. 1. On the drum, X crowned. 2. In four small shapes, (a) P.M.; (b) female figure between "P. M.": (c) Leopard's face; (d) Lion rampant to the sinister. 3. On the bottom inside; Stag's head couped at the neck, "W. W." above, "1751" below, within an oval.

This is a straight-sided flagon narrowing towards the top, having a rounded lid, an R shaped handle, and a purchase with a heart pierced in it.

PEWTER BASIN. Diam. $9\frac{1}{8}$ in. Depth $1\frac{1}{4}$ in.

Marks. 1. Eagle displayed, "Thomas" above, "Hodgkin" below. 2. X crowned. 3. "London" in an ornamental oblong.

This is quite a plain basin.

PEWTER PLATE. Diam. $9\frac{1}{2}$ in.

Marks. 1. Seeded rose with a fleur-de-lis above, "John" above, "Jupe" below. 2. "Superfine French Metal."

This is a flat salver with a raised edge, standing on three feet.

The modern silver cup and its plated cover, the silver paten and the plated flagon and patens, were presented to this church, by J. R. Edmonds, Esq., of Charnwood House, Sibley.

OAKS.

SILVER PLATED CUP. Height $7\frac{5}{8}$ in. Diam. of the bowl $4\frac{1}{2}$ in.; of the foot $3\frac{3}{8}$ in. Height of stem $3\frac{1}{4}$ in.

This cup has a straight-sided bowl, a narrow round stem divided in half by a round moulding between two smaller ones for a knob, and a plain, round foot. Upon the bowl is this inscription; "*The gift of Miss Elizabeth Babington, 1817.*"

SILVER PLATED PATEN. Diam. $8\frac{1}{4}$ in.

This is a plain plate, having in its centre the same inscription as that on the cup.

SILVER PLATED FLAGON. Height $11\frac{1}{4}$ in. Diam. at the top $4\frac{5}{8}$ in.; at the foot $6\frac{1}{2}$ in.

This is a straight-sided flagon, narrowing towards the top, at which is a large spout. It has a round top to its lid and an open purchase. Upon one side is the same inscription as that on the cup.

At the time of the enclosure of Charnwood Forest, for which an Act of Parliament was obtained in 1808, two hundred and twenty acres of land were set apart for the endowment of any new churches which might be built within the Forest; it being foreseen that such churches would be necessary owing to the probable increase of the inhabitants within this district after the enclosure.

The first church built was this one, which was consecrated on the same day that the battle of Waterloo was fought. The cost of its erection was defrayed by voluntary subscriptions. An ecclesiastical parish was assigned to it in 1852. In 1884 it was rebuilt at a cost of £4000, by Mrs. Perry Herrick, of Beaumanor.

Miss **Elizabeth Babington** was a member of the ancient Leicestershire family of that name, long seated at Rothley Temple. She was the only daughter of the Rev. **Matthew Babington**, vicar of Rothley, by his wife **Elizabeth**, only child of **Richard Roberts Drake**, Esq., of Leicester, and was baptized at Rothley on 16th Sep., 1791.* She was married at Naples in 1829 to **Robert Strange**, Esq., M.D., of Naples, and died there without issue in 1847. Dr. **Strange** survived his wife for several years, dying at Elvaston Place, Kensington, in 1872.

COPT OAK.

SILVER PLATED CUP. Height $6\frac{3}{8}$ in. Diam. of the bowl $3\frac{1}{2}$ in.; of the foot $2\frac{5}{8}$ in. Height of stem $2\frac{1}{2}$ in.

This is a plain cup with a straight-sided bowl and a narrow round stem.

* Parish Register.

SILVER PLATED PATEN with a foot. Diam. 6 in. Diam. of the foot 3 in. Height of foot $2\frac{1}{2}$ in.

This is a plain paten, standing on a narrow round stem that swells into a round foot.

SILVER PLATED PLATE. Diam. 6 in.

This is the same as the paten, without the foot.

These three pieces, which are copper silver plated, were bought for this church by the parishioners in 1860, at the time when Copt Oak was made into a separate ecclesiastical parish. The church is served by the incumbent of Oaks: it was built in 1837 by the Earl of **Stamford**, with the help of a grant from the Ecclesiastical Commission, and was repaired in 1870 by the late **W. P. Herrick**, Esq., of Beaumanor.

QUORNDON.

SILVER CUP. Weight 10.4 oz. Height $7\frac{3}{8}$ in. Diam. of bowl and foot 4 in. Height of stem $3\frac{1}{2}$ in. Date 1738?

Hall marks. 1. Possibly capital Roman C in a plain shield. 2. Leopard's head crowned in a plain shield. 3. Lion passant in a plain oblong. 4. K in a square, indistinct.

This cup has an egg-shaped bowl standing on a straight narrow stem swelling into the bowl and foot, the latter being rounded off into a wide flat edge round which runs a beaded moulding; the same kind of moulding is placed round the middle of the stem.

SILVER PATEN. Weight 10.4 oz. Diam. $7\frac{1}{4}$ in. Date 1775.

Hall marks. 1. Capital old English U in a square shield. 2. Leopard's head crowned in a rounded shield. 3. Lion passant in a plain oblong. 4. R. R. in double-lobed oblong. Mark of *Richard Rugg*.

This was originally a secular piece of plate, being a salver with a raised hexagonal edge ornamented with a beaded moulding. Below are three feet, each in the shape of an eagle's claw holding a ball. In the centre is the sacred monogram with a cross and three nails in a circle of glory.

SILVER CUP. Weight 14.5 oz. Height $9\frac{1}{4}$ in. Diam. of the bowl $3\frac{3}{8}$ in.; of the foot $4\frac{1}{8}$ in. Height of stem 5 in. Date 1839.

London hall marks.

This cup has a straight-sided concave bowl with a rounded base standing on a plain round stem and foot. In front of the bowl is the sacred monogram with cross and nails in a circle of glory.

SILVER DISH with a foot. Weight 21.2 oz. Diam. $9\frac{1}{2}$ in. Diam. of foot $4\frac{1}{2}$ in. Height of foot $3\frac{1}{8}$ in. Date 1839.

This is a perfectly plain dish standing on a large hollow foot. In the centre is the sacred monogram.

SILVER FLAGON. Weight 42.9 oz. Height $14\frac{1}{4}$ in. Diam. at the top $3\frac{3}{4}$ in.; at the foot 6 in. Date 1839.

This is a tall straight-sided flagon narrowing towards the top, at which is a spout. The lid is surmounted with an ornamental knob. On one side of the drum is the sacred monogram.

PEWTER FLAGON. Height $10\frac{1}{2}$ in. Diam. at the top $4\frac{1}{8}$ in.; at the foot 6 in.

Marks. 1. On the drum, Lion passant in shaped stamp repeated four times; 2. X crowned. 3. On the bottom inside, X crowned; 4. H. I. in shaped oblong.

This is a straight-sided flagon with an R shaped handle.

PEWTER DISH. Diam. $12\frac{1}{4}$ in.

Marks. 1. X crowned. 2. "Made in London," on scroll. 3. Lion rampant in ornamental frame, "W. Cook" above. 4. Seeded rose crowned in ornamental frame. 5. On back, "Quarn."

The silver salver, now used as a paten, was presented to this church about ten years ago by Mr. **Joseph Tacey**, of Rose Cottage, in this parish, who has been for several years the vicar's churchwarden.

The three modern pieces of silver plate were the gift of **Harriet**, the widow of **Edward Farnham**, Esq., of Quorndon House. This lady was the youngest daughter and co-heir of the Rev. **Durand Rhudde**,* D.D., rector of the three livings of Brantham, East Bergholt, and Great Wenham, co. Suffolk, and chaplain in ordinary to the King, by **Mary Shergold**.† She was married to **Edward Farnham**, Esq. in April, 1795.† Mr. **Farnham** was the representative of the ancient Leicestershire family of that name, which has been seated in this parish from the time of **Edward I.**‡ He was born on 27th May, 1753, succeeded his brother, **Thomas Farnham**, in 1793, and was high sheriff of the county in 1817. He died on 7th Jan., 1835, leaving by his wife, **Harriet**, a son, **Edward Basil**, his successor, and two daughters, **Sarah Anne**, who died unmarried, and **Mary Eliza**, who married the Rev. **William C. Henniker**, rector of Great Bealings. Mrs. **Farnham** died on 27th July, 1854. Upon the West wall of the **Farnham** chapel, which opens out of the South aisle of this church, is a handsome alabaster canopied mural monument to the memory of Mr. **Edward Farnham** and the donor of these pieces of plate, upon which are two short inscriptions, and, in the lower part four shields bearing these arms: 1. *Gules, a fleur-de-lis, Argent, billeté, Sable, Billington.* 2. *Quarterly, Or and Azure, in the two first quarters a crescent counterchanged, Farnham.* 3. *Blank.* 4. *Azure, three boars passant Or, Whatton.*

* Married at St. Dionis, Backchurch, on 16th Aug., 1760; Parish Register. He was Lecturer of St. Dionis Vicar of St. Thomas, Southwark. Vicar of Sheperdswell. M.I. to both in Bergholt church; he died 6th May, 1819, aged 85, she 19th March, 1811, aged 73.

† *Geneal. Mag.*, Vol. 65., pt. i., p. 346.

‡ For pedigree, see *Leicestershire Pedigrees* by Rev. W. G. D. Fletcher, p. 107.

ROTHLEY.

SILVER CUP. Weight 14.2 oz., including lead in stem. Height $7\frac{3}{8}$ in. Diam. of bowl and of foot $3\frac{5}{8}$ in. Height of stem $3\frac{1}{2}$ in. Date 1569. (PLATE 5.)

Hall marks. 1. Small old English M, in a plain shield. 2. Lion passant. 3. Leopard's head crowned; each of the two latter having an outer line. 4. Possibly a maunche in a rounded shield.

This cup is of the usual Elizabethan shape, having a tall bowl, straight-sided nearly in its lower part, swelling out higher up into a bell-shaped lip: round the bowl is a band of foliage divided into three parts by hour-glass curves. The stem is evenly balanced and divided in half by a knob formed by a large round moulding on a fillet. The foot is rounded off into a flat sloping edge, upon which is the egg and tongue ornament; a band of the same runs round the bottom of the bowl. In 1878 this cup was repaired; its dints were beaten out, the bottom of the bowl was renovated, and the inside gilt; also a large plate of silver was placed underneath the foot to hide the lead then put inside the stem.

SILVER CUP. Weight 9.1 oz. Height $7\frac{1}{2}$ in. Diam. of bowl and of foot $3\frac{5}{8}$ in. Height of stem $3\frac{1}{2}$ in. Date 1802.

London hall marks.

This cup is exactly the same in shape as the older one, having been evidently copied from it. It differs, however, from the first in having no ornament of any kind whatever upon it.

SILVER PATEN, parcel gilt. Weight 4 oz. Diam. $5\frac{3}{8}$ in. Date 1878.

Birmingham hall marks.

This is a flat paten, gilt on the top, a small cable moulding running round its edge. In the centre, within a quatrefoil, is a floriated cross.

SILVER PATEN. Weight 3.9 oz.

Same as last.

These two patens were the gift to this church of **J. R. Edmonds**, Esq., of Charnwood House, Sileby. This gentleman defrayed the cost of the repairs made in the ancient cup, and gave also a glass flagon with silver electro-plated fittings: before this gift was made, a large silver-plated flagon and paten, of modern make, were used here.

SHEEPSHED.

(a)

SILVER CUP. Weight 17 oz. Height $8\frac{5}{8}$ in. Diam. of bowl $5\frac{1}{8}$ in.; of foot $4\frac{5}{8}$ in. Height of stem 3 in. Date 1687. (PLATE 6.)

Hall marks. 1. Small black letter K in plain shield. 2. Lion passant in oblong. 3. Leopard's head crowned in a circle. 4. S. H. in monogram, within oval.

This cup has a deep straight-sided bowl, resting on a plain thick stem, without any knob, which swells out towards the bowl and into a foot ending in an ovolo moulding. Round the bowl is this inscription; "*The gift of the Lady Phillippes, of Garraden, to the church of Shepshead, Anno 1687.*"

(b)

SILVER PATEN with foot. Weight 11.3 oz. Diam. 8 in. Diam. of foot $4\frac{3}{4}$ in. Height of foot $3\frac{7}{8}$ in. Date 1867.

Birmingham hall marks.

In the centre of the paten, which is quite plain, is the sacred monogram and this inscription; "*Given by the Rev. Charles Lisle March Phillips, M.A., Vicar, to the parish church of Sheepshed, on Easter Day, Anno Domini 1868.*"

(c)

SILVER TWO HANDED CUP WITH COVER. Weight, including cover, 59.1 oz. Height of cup without cover 7 in. Diam. at top $6\frac{1}{4}$ in.; at the foot $4\frac{1}{2}$ in. Height with cover on $10\frac{1}{2}$ in. Date 1749. (PLATE 6.)

Hall marks. 1. Small Roman O in shaped shield. 2. Leopard's head crowned in shaped shield. 3. Lion passant in shaped oblong. 4. J. S. with a crown above and a rose below.

This cup is straight-sided in shape, rounded off below, with a raised cover, surmounted with a knob of the same shape as the cup and cover. It is not at all unusual to find the knob of one of these kind of cups to be in shape a miniature of the whole piece. In front is the following inscription; "*Presented to Sheepshed Church by the Rev. Thomas Heath, M.A., Vicar of the parish during forty years. Died Oct. 18th, 1765.*"

TWO PEWTER DISHES. Diam. $9\frac{1}{2}$ in.

Marks. 1. X crowned. 2. A dexter arm the hand holding a spear, rising out of a crown. 3. "London." 4. In four small shields: (a) Leopard's head; (b) dexter arm with spear; (c) fleur-de-lis; (d) S. H.

There were formerly here two pewter flagons and two pewter patens with feet. These were sold a few years ago to the Rev. **Joseph Merriman**, head master of Surrey County School, who had them made into an altar cross for his school chapel. On the two pewter patens was the following inscription; "*The gift of ye Lady Phillipps of Garraden, to ye Church of Shepshed, Anno 1687.*"

(a)

The donor of the silver cup, and of the pewter patens formerly here, was **Mary**, the daughter of **William Rickards**, "soap boiler," of London, by **Jane**, his wife. She was baptized at St. Clement Danes, on 22nd May, 1649, and married in the same church on 3rd Dec., 1668,* **Ambrose Phillipps**, Esq. This gentleman was the son of **Ambrose Phillipps**, of Clare Market, Strand,† and was educated at Winchester and New Coll., Oxford, taking his B.A. on 3rd May, 1661. He was a leading barrister of the Middle Temple, and bought the estate of Garendon with the principal part of Hathern in 1683, becoming possessed of Gracedieu a few years later. On 11th April, 1686, he was knighted by King **James II.**, and made a king's serjeant in August following. He died 16th June, 1706, aged 69, and was buried in the

chancel of Sheepshed church. Lady **Phillipps** survived Sir **Ambrose** until 17th Oct., 1736, when she died at Crux Easton, Hampshire, at the age of 88. She was buried by the side of her husband on 2nd Nov. On the North side of the East window in the chancel of this church is a monument to Sir **Ambrose Phillipps, Kt.**, erected by his Lady, upon which is a short inscription to herself, and also these arms; "*Azure a chevron between three martlets Argent; Phillipps; impaling; Gules a bend vairé between two garbs Or; Rickards.*"*

By the donor of this piece of plate Sir **Ambrose Phillipps** had with three sons, a daughter, **Mary**, married to **Edward Lisle**, of Crux Easton; their daughter **Jane** married **Thomas March**, of London, whose son **Thomas** eventually inherited the estates purchased by Sir **Ambrose Phillipps**, and took his name; from him these estates have passed in regular succession to their present owner, **Everard March Phillipps de Lisle**.

By her will dated 15th May, 1731, and proved P.C.C. with four codicils on 17th Nov., 1736, Lady **Phillipps** left sums of money to her daughter in law **Jane Phillipps**† with her children **Ambrose** and **Mary**; to **Elizabeth**, daughter of her son **Charles Phillipps**; to her grandsons **Edward** and **William Lisle**; to these other children of her daughter **Mary Lisle**, £500 each, viz.: **John**, **Thomas**, **Jane**, **Anne**, **Susan**, **Sophia**, **Sarah**, **Frances**, **Richard**, and **Harriet**; to her other grandson **Charles Lisle**, Lady **Phillipps** forgave a debt; to her granddaughter **Catherine Allen**, with her husband **Thomas Allen**, she left a legacy; to the poor of Sheepshed, Hathern, and Dishley, she left £20 amongst them. Her sons **John** and **Charles Phillipps** she appointed her executors and residuary legatees.

(b)

The donor of the silver paten was the second son of **Charles March Phillipps, Esq.**, of Garendon, M.P. for Leicestershire, by his wife **Harriet**, youngest daughter and co-heir of **Gustavus Ducarel**, of Walford, Somerset, Marquis de **Chateaubay** in France, and was born on 6th March, 1812. Mr. **Phillipps** graduated from Magdalene College, Cambridge, taking his B.A. degree in 1835 and M.A. in 1838. He was ordained deacon in 1844 and priest in 1845, and was appointed to the vicarage of Queniborough in 1846, where he remained for ten years, when he was presented to the vicarage of Sheepshed, which he held till his death on 3rd Jan., 1875. The Rev. **Charles Lisle March Phillipps** married **Elizabeth**, only child and heir of **John Dixon, Esq.**, by which lady, who survives her husband, he had no issue. Mr. **Phillipps** was buried in the churchyard of this parish near the tower; a plain white marble headstone marks his grave.

(c)

The following clause in the Rev. **Thomas Heath's** will, made 8th Oct., 1765, and proved on the 21st following P.C.C., reveals the origin of the two-

* *Nichols*, Vol. iii., p. 1021 describes these arms incorrectly.

† Wife of William Phillipps.

handled cup; "*I give my great silver cup and cover, given by Mrs. Phillips, to the church of Sheepshed; and if its present form is not approved of it may at any time at the expense of the parish be changed for a flagon of the same metal and as near as may be of the same weight.*"

This gentleman sprang from a Staffordshire family owning land at Cheadle. He was the son of **John** and **Hannah Heath**, of that place, and was baptized there on 21st Feb., 1695* He was presented to the living of Sheepshed in 1725, and to that of Hathern in 1732. Mr. **Heath**, who was unmarried, held both livings until his death on 18th Oct., 1765. He was buried in the churchyard of this parish, where a monument stands over his grave bearing a short inscription, in which his life is said to have been spent "in the regular and uniform exercise of all Christian virtues."

He bequeathed £5 to each of the parishes of Sheepshed and Hathern for their poor. His property which he had bought in Dilhorn, co. Staff., he left to his brother **John Heath**: legacies were left to various nephews and nieces; one amongst others to the daughter of his late nephew **William Heath**, of Cheadle.

SWITHLAND.

SILVER CUP. Weight 17.8 oz. Height 8½ in. Diam. of the bowl 4 in.; of the foot 4½ in. Height of stem 4½ in. Date 1757. (PLATE 7.)

Hall marks. 1. Capital old English B in a square shield. 2. Leopard's head crowned in an oval shield. 3. Lion passant in a plain oblong. 4. A. V. script letters, a mullet of 6 points above, a pellet below, within a quatrefoil. The mark of *Ayme Vedean*.

This cup has a bell-shaped bowl resting on a tall narrow stem. Upon the bowl is engraved the sacred monogram with a cross above and three nails below, within a circle of glory.

SILVER CUP. Weight 16.1 oz.

Exactly like the last.

TWO SILVER PATENS with feet. Weight of each 5.1 oz. Diam. 4¾ in.; of foot 2¼ in. Height of foot 1¼ in. Date 1757. (PLATE 7.)

Hall marks the same as on the cups.

These patens are flat with raised edges finished off with small mouldings. Upon the foot of each is engraved the sacred monogram as on the cups.

SILVER FLAGON. Weight 53.4 oz. Height 11½ in. Diam. at top 3¼ in.; at foot 5 in. Date 1757. (PLATE 7.)

Hall marks the same as those on the cups.

This is a jug-shaped flagon, made of very thick metal, with a spout at the top, a round top to its lid and an R shaped handle. In front is engraved the sacred monogram as on the cups.

SILVER ALMS DISH. Weight 36.1 oz. Diam. 14½ in. Date 1757.

Hall marks. 1, 2, and 3, as on cups. 4. R. I. a pellet between, within an oblong. Mark of *Robert Innes*.

This is a large plain alms dish having in its centre a raised boss, upon which is engraved the sacred monogram as on the cups.

SILVER ALMS DISH. Weight 25.7 oz. Diam. 11 in. Date 1768.

Hall marks. 1. Capital old English N in a square shield. 2. Leopard's head crowned in an oval shield. 3. Lion passant in a plain oblong. 4. T. K. in an oblong.

This is a basin-shaped dish with a gadrooned edge. In the centre is the sacred monogram as on the cups.

SILVER CANDLESTICK. Weight 12.6 oz. Height 9¾ in. Diam. at the top 2¾ in. ; at the foot 5¾ in. Date 1701. (PLATE 7.)

Hall marks. 1. Court hand F. 2. Britannia. 3. Lion's head erased. 4. Capital old English S and a small Y, in a circular stamp. Mark, perhaps, of *Richard Syngin*.

This is a handsome candlestick with a round fluted stem resting upon a square projecting platform with a gadrooned edge, below which the stem widens out into a square foot nearly flat at the top. The top of the candlestick is flat and square. The corners of this top, of the platform below the stem, and also the corners of the foot, are all clipt. Upon one side of the foot, within a small oval where one would expect to find a coat of arms, is the sacred monogram, as on the cups.

SILVER CANDLESTICK. Weight 12.1 oz.

Like the first in every respect.

SILVER TRAY. Weight 4.1 oz. Diam. 5½ in. Date 1727. (PLATE 7.)

Hall marks. 1. Capital Roman M in a square shield. 2. Leopard's head crowned in a round shield. 3. Lion passant in a plain oblong. 4. E. C. in an oval oblong. Mark of *Edward Cornock*.

This is a square flat tray with the corners clipt. Its edge is turned up vertically ¾ in. high. Below are four feet, one at each corner. Upon the top of the tray is some embossed ornament, and in the centre is the sacred monogram as on the cups. On the back are the initials, H. I. M.

SILVER TRAY. Weight 5.5 oz. Date 1730.

Hall marks. 1. Capital Roman P in a pointed shield. 2. Leopard's head crowned in a pointed shield. 3. Lion passant in a plain oblong. 4. S. C. in an oval shape.

This tray is the same in shape as the last, but having embossed ornament different in design on the top. Underneath are the initials, S. B. C.

These two trays, and also the candlesticks, were evidently originally secular pieces of plate; the sacred monogram being placed upon each piece at the time when they were bought for this church.

The following extract from *Nichols*, Vol. iii. p. 1050, throws light upon the origin of this communion service; "A neat modern set of satuary marble by Hayward, a fine organ by Snetzler, and a noble service of communion plate, consisting of a large dish, a large flagon, two cups and covers, two salvers, and two candlesticks were given by the late baronet."

The donor of this service was Sir **John Danvers**, Bart., the last direct male representative of an ancient Leicestershire family, seated originally, soon after the Norman Conquest, at Frowlesworth, subsequently at Shackerton, where the family owned a property up to 1674. This family gained their estates at Swithland through the marriage of **John D'Anvers**, in the time of **Henry VI.**, with **Margaret**, daughter and co-heir of Sir **William Walcote**, of Walcote and Swithland.* Their direct descendant Sir **John Danvers**, Bart., was the only son of **Joseph Danvers**, of Swithland, by his wife **Frances**, second daughter of **Thomas Babington**, of Rothley Temple, and was baptized at Swithland on 28th Nov., 1723. Sir **John** was a large landowner, his estates lying not only in this county, but in the counties of Northampton, Bedford, Oxford, and Middlesex. He was high sheriff of Leicestershire in 1755: his political sympathies, judging from the inscription on his monument, were with the Whigs. He died at Bath, where he lived during the last four years of his life, on 21st Sep., 1796, and was buried in Swithland church; upon the West wall of which he had erected a white marble monument bearing a long inscription written by himself; in which it is said, "his bounty beautified this church, and rebuilt the parsonage." Sir **John Danvers** married at Clapham, on 10th Oct., 1752, **Mary**, daughter and co-heir of **Joel Watson**, Esq., of Clapham, which lady eventually inherited the property of her only sister Mrs. **Delaval**; she died in August 1798, and was buried in Bunhill fields; leaving a daughter, **Mary**, who alone survived her father: which lady carried the property of the ancient family of **Danvers** to her husband, the Hon. **Augustus Richard Butler**, who took the name and arms of **Danvers**, in addition to his own. This gentleman by his first wife, **Mary Danvers**, was the father of the 5th Earl of **Lanesborough**, and by his second wife, **Elizabeth Sturt**, the grandfather of the 6th and present Earl, the owner of Swithland hall.

The arms of **Danvers** are; *Argent, on a bend Gules, three martlets of the field.*

It will be noticed that the second alms dish is not mentioned by *Nichols* in his list of communion plate. Nothing positive can be said of its origin.

THORPE ACRE WITH DISHLEY.

SILVER CUP. Weight 6.1 oz. Height 5 in. Diam. of bowl $3\frac{1}{8}$ in.; of foot $2\frac{3}{4}$ in. Height of stem 2 in. Date 1701. (PLATE 5.)

Hall marks. 1. Court hand F. 2. Lion's head erased. 3. Britannia. 4. P.C.† with pellets between the letters, within an oval.

* *Nichols*, Vol. iv., p. 189.

† The second letter is not plain, but is I think a C.

The bowl of this cup is straight-sided, a little curved out at the lip; it stands on a very short baluster stem, and a plain foot with the edge turned back underneath. The Lion's head erased is repeated underneath the foot. On the side of the bowl is engraved "Dixley."

SILVER CUP. Weight 8.6 oz. Height $7\frac{1}{2}$ in. Diam. of bowl $3\frac{5}{8}$ in.; of foot 3 in. Height of stem $3\frac{3}{8}$ in. Date 1845.

London hall marks.

The bowl of this cup is straight-sided, being slightly bell-shaped. In front is the sacred monogram within a circle of glory. The stem has a small round moulding for a knob.

SILVER PATEN with foot. Weight 8 oz. Diam. $5\frac{3}{4}$ in. Diam. of foot $2\frac{3}{4}$ in. Height of foot $2\frac{1}{2}$ in. Date 1845.

London hall marks.

This is a plain paten, having in the centre the sacred monogram within a circle of glory.

SILVER PLATED FLAGON. Height $11\frac{1}{4}$ in. Diam. at top $3\frac{3}{8}$ in.; at foot $6\frac{1}{8}$ in. This is a straight-sided flagon with a spout.

PEWTER DISH. Diam. 8 in.

Marks. 1. Prince of Wales' feathers rising out of a crown with "J. Hardman" above; "Lethbarow" below; this mark is repeated twice: Below this is "J. Hardman," with "Tharp Akar. D." below. 2. in four oblongs, (a) Lion passant. (b) Leopard's head. (c) a cock. (d) I. H.

PEWTER DISH.

Same as the first but with no marks on it, only "Tharp Akar. D." D. possibly stands for Dishley.

The ancient silver cup, and the two pewter plates, were used in Dishley church until the new church was built at Thorpe Acre, by subscription, in 1845. It is perhaps worth mentioning, that John Ransdale, yeoman, of Thorpe Acre, ordered his executrix in his will made on 1st April, 1708, and proved in Leicester on 14th July, 1711, to buy a table cloth of good linen, and a napkin for the Holy Communion at Dixley. He bequeathed ten acres of land in Barrow-on-Soar, for the benefit of the poor in Thorpe Acre, and Knight-thorpe. Dishley church is now without a roof, and in a ruinous condition.

The modern silver cup and paten, were provided for the new church, it is said, at the cost of the Rev. John Bridges Hooker Ottley, who was appointed to this living in 1845. It was mainly through this gentleman's exertions, that the church, and also the vicarage house were built. He died on 12th March, 1879, aged 81, and was succeeded by his son, the Rev. F. J. Ottley, who presented the silver plated flagon to this church.

THURCASTON.

SILVER CUP. Weight 10.8 oz. Height $7\frac{3}{8}$ in. Diam. of bowl $4\frac{1}{4}$ in.; of foot $4\frac{1}{8}$ in. Height of stem 3 in. Date 1707.

Hall marks. 1. Court hand M. 2. Lion's head erased. 3. Britannia. 4. I. L. in old English capitals, but indistinct.

This cup has a bowl nearly straight-sided in shape, with a raised lip. The stem is $1\frac{1}{4}$ in. thick and straight, having for a knob a small round moulding between two hollows. The foot, which is flat at the top, ends in an ovolo moulding and a flat edge, the lion's head erased being repeated underneath. The bowl of this cup is beaten out of one piece of silver, the stem and foot out of another. The knob is made out of a separate band of metal fastened round the stem. Upon the bowl is this inscription; "*Thurcaston. Exchanged and enlarged by Mr. Hill, Rector, May 22, 1708.*"

SILVER PATEN. Weight 15.4 oz. Diam. 10 in. Date 1713.

Hall marks. 1. Court hand S. 2. Lion's head erased. 3. Britannia. 4. W. I. a fleur-de-lis below in a shaped shield. The mark of *John Wisdome*.

This is a plain paten with a flat edge, round which is this inscription; "*Thurcaston. To God and His Church this is humbly Dedicated by Mrs. Helen Hill, Wife of Rich. Hill, Rector, May 22, 1712.*"

SILVER FLAGON. Weight 39.1 oz. Height $10\frac{5}{8}$ in. Diam. at the top $4\frac{1}{4}$ in.; at the foot $6\frac{5}{8}$ in. Date 1713.

Hall marks, as on paten.

This is a straight-sided flagon, narrowing to the top. The lid is round at the top. The lion's head is repeated under the foot. In front there is the same inscription as that on the paten.

The following entry was made with reference to this communion service, by Mr. Hill, in the parish account book, recording the offertories and charities:

"1714. Upon Easter Day, being March 28, 1714, I, Rich. Hill, Rector, offered at y^e Holy Communion a silver Flagon and Plate, which were given by my Dearest, most Humble, and most Pious Wife, Mrs. Helen Hill, da^rter of Cecil Tyrwhitt, of Camringham, near Lincoln, Esq. The weight of y^e Flagon is 39 oz. and 2 dwts. Each of ym^e has upon it one and y^e same inscription, word for word, as follows; '*Thurcaston,*' etc., '*May 22, 1712.*' W^m God first sent me Rich. Hill to be Rector of this Church there was in it an old, small, thin Silver Cup, w^h was much worne, and had in y^e mouth of it several slits. It had on it no Inscription nor date. I exchanged it at my own Expense and engraved on it y^e following inscription; '*Thurcaston,*' etc., '*May 22, 1708.*'"

From a terrier at Lincoln made in 1709 we learn that there then belonged to this church, in addition to the cup given by Mr. Hill, "two pewter flagons, one inscribed '*George Bradshaw, Samuel Tomkin, Churchwardens, 1686;*' a large pewter paten, same inscription; a little pewter plate to collect the offerings." The pewter flagons and one of the plates were parted with after Mrs. Hill's gift of silver vessels had been made. In the terrier for 1745 we are told that "there still remains a poor pewter thing to collect the offerings."

The Rev. Richard Hill, B.D., was a member of a yeoman family owning land for many years in Shenstone, co. Worcester.* He was the son of Humphrey Hill, of that place, by Ann, his wife, and was baptized in the parish church at Stone on the 12th July, 1656.*

* Parish Register.

He was sent to Uppingham School, and from there obtained a sizarship at Emmanuel College, Cambridge, on 10th Dec., 1675; from whence he took his B.A. in 1679, M.A. in 1683, B.D. in 1690. He was elected fellow of his college on 14th July, 1682: on the 23rd Dec., 1683, he was ordained deacon, taking priest's orders on 21st Sep. in the following year. During the first years of his clerical life Mr. Hill resided in college and served two curacies in succession in the neighbourhood of Cambridge, doing this until 22nd May, 1701, upon which day he was elected by his college to the living of Thurcaston. This piece of preferment enabled him to take to himself a wife, which he did on 14th April, 1702, when he married **Hester**, the eldest daughter of **William Sanderson**, of Pilton, Northants., by whom he had two daughters; the eldest died young, the other, **Hester**, became the first wife of **Edward Wigley**, M.D., of Ullesthorpe, in Sep., 1722, but lived only till the 10th of Nov. following. Mrs. Hill died on 16th Oct., 1705. Her husband subsequently married a second wife, **Helen Tyrwhitt**, the donor of the flagon and paten to this church. This lady, a member of an ancient Lincolnshire family, was the daughter of **Cecil Tyrwhitt**, of Cameringham; she died, leaving no issue, on 7th July, 1713. Mr. Hill himself died rector of this parish upon 7th Feb., 1732, and was buried between his two wives in the chancel of this church: over their graves are slabs bearing short inscriptions.

The memory of this benevolent divine will live long in the parish of which he once had spiritual charge, for here he founded a school in 1715,* which he built on a portion of the glebe, and endowed with twelve acres of land in Six Hills and seven in Anstey. By the sale in 1875 of the former piece of land enough money was realised to build a new school. The remaining property produces an income of £26 a year.

Mr. Hill performed a similar good work for his native parish by bequeathing in his will dated 1730, and proved in Leicester in 1732, twenty-four acres of land at the Hoo for the support of a charity school at Stone, directing the children from Shenstone to be admitted free. That special privilege was withdrawn when a better education was provided by a scheme formed by the Charity Commissioners in 1881, in which Mr. Hill's bequest was merged with others.

From an achievement formerly in Thurcaston church we learn that Mr. Hill bore these arms; *Azure a chevron between three fleur-de-lis Or; a canton of the last.*

The arms of **Tyrwhitt** are; *Gules three lapwings Or.*

It seems that Mrs. **Helen Hill** had set apart a sum of money for her gift during her life, but that the purchase was not actually made until after her death. We may conclude that her husband put "May 22" in each inscription in order to commemorate the day of his election to the living.

* See *Nichols*, Vol. iii., p. 1074, for statutes of this school as drawn up by the founder.

WANLIP.

(a)

SILVER GILT CUP. Weight 13.7 oz. Height $7\frac{1}{4}$ in. Diam. of the bowl and of the foot $4\frac{1}{2}$ in. Height of stem $3\frac{5}{8}$ in. Date 1636. (PLATE 5.)

Hall marks. 1. Italic T in a plain shield. 2. Leopard's head crowned. 3. Lion passant; the two last within an outside line following their outline. 4. G. S., a ladle between the letters, within a shaped stamp.

This strongly-made cup has a bowl shaped into an inverted truncated cone, with a flat base; and a baluster stem standing on a flat sloping foot with some lines running round its edge, the latter being turned inwards. The lion passant is repeated underneath the foot. Upon the bowl is this inscription; "*The gift of Archdale Palmer, Esq., to the Parish Church of Onlepp,* 1636.*"

SILVER GILT PATEN with a foot. Weight 4.5 oz. Diam. $5\frac{5}{8}$ in. Diam. of the foot $2\frac{1}{4}$ in. Height of foot $\frac{5}{8}$ in. Date 1636. (PLATE 5.)

Hall marks as on the cup.

This paten fits on to the cup with the foot downwards. It has a flat edge, from which the middle is slightly sunk. The foot is a disk attached to the paten by a stem swelling out at both ends. Upon the edge is the same inscription as that on the cup. The gilding on this cup and paten is nearly worn off.

(b)

SILVER BASIN. Weight 3.4 oz. Diam. $6\frac{5}{8}$ in. Depth $1\frac{1}{4}$ in. Date *circa* 1680. (FIG. 5.)

No marks.

This little basin is of German make, and is covered with flowers and foliage repoussé beautifully executed in pleasing curves. In the centre, within a wreath, is a winged heart, clouds above and below, perhaps typifying the divine love as shewn to man in the Incarnation of the Son of God. Some object descends to the heart from the clouds above.

Upon the edge of the dish is "*Wanlip, 1815.*"

SILVER DISH. Weight 6.4 oz. Diam. $8\frac{3}{8}$ in. Depth $1\frac{1}{4}$ in. Date *circa* 1680.

No marks.

This is also a basin-shaped dish, perhaps of Spanish make, its edge being shaped into twelve lobes, in each of which is a conventional flower, every other one being a rose. In the centre of the dish is a lamb, rays of glory descending from above.



Fig. 5. *Circa* 1680. Half full size. F. H. M. del.

* The Engraver first cut "tt" instead of "pp."

The ornamentation is stiffly designed and rather rudely beaten out. "Wanlip, 1815," is engraved upon this dish. Both this and the other basin belonged originally to some foreign church. They are basins such as the celebrant washes his hands in before consecrating the sacred elements.

SILVER FLAGON. Weight 50.1 oz. Height $12\frac{1}{2}$ in. Diam. at the top $4\frac{1}{2}$ in.; at the foot $4\frac{3}{8}$ in. Date *circa* 1780.

Marks. 1. Capital Roman L crowned in a shaped stamp. Assay mark of Lisbon.*
2. N above I. T. in a shaped stamp.

This is a solid jug-shaped flagon with a wide lip and spout, standing on an octagonal-shaped foot. The sides are fluted diagonally. Round the lower part and on the foot, lid, and handle, is some stiff renaissance ornament, repoussé. On the top of the handle has been this inscription, part of it being now obliterated; "Presented to Wanlip Church by Sir C. T. Palmer, Bart., 1815." This flagon was evidently originally a secular piece of plate.

(a)

The donor of the silver gilt cup and paten was the eldest son of **William Palmer**, citizen of London, and the purchaser of Wanlip from **Sir Walter Aston**, by his wife **Barbara**, daughter of **Thomas Archdale**, of Wycombe, Bucks. **Archdale Palmer**, who was born in 1609, made this gift to Wanlip church soon after he succeeded his father to his estates in this parish. He was twice high sheriff of Leicestershire, in 1641, when he was displaced by the King, and in 1654. He died on 6th Aug., 1673, and was buried in the chancel of Wanlip church, on the North wall of which is a black marble tablet to his memory, bearing an inscription in Latin† and these arms: *Argent on two bars Sable three trefoils of the field, in chief a hound courant of the second collared Or, Palmer; impaling; Azure two bars between three pheons Or; Smith.* The inscription on this donor's monument tells that he was descended from a Yorkshire family, through a younger branch which had settled at Marston, co. Staff.‡ **Archdale Palmer** married *circa* 1634 **Martha**, third daughter of **Thomas Smith**, of London, merchant,§ which lady was buried here on 18th Dec., 1679. By her, with several other children, he had an eldest son, **William**, whose great-granddaughter, **Catherine Susan Palmer**, brought the Wanlip estates to her husband **Charles Grave Hudson**, created a Bart. in 1791.

(b)

The donor of the remaining pieces of plate, **Sir Charles Thomas Palmer**, Bart., was the eldest son of the above **Sir C. G. Hudson**, Bart., by **Catherine Susanna**, eldest daughter and co-heir of **Henry Palmer**, Esq., of Wanlip, and was born in St. Clement Danes, Middlesex, on 20th May, 1771. He was educated at Christ Church, Oxford, from whence he took his B.A., in 1794. This gentleman upon succeeding to the Wanlip estates in

* As Mr. Cripps thinks, judging from impressions of the marks.

† See *Nichols*, Vol. iii., p. 1099.

‡ *Visit. London*. Publications of the Harl. Soc., Vol. xvii., p. 141.

§ *Ibid*, p. 243.

1813 assumed the name of **Palmer**. He died on 20th April, 1827, and was buried at Wanlip. In the church of that parish is a mural monument to his memory upon which is a lengthy and laudatory inscription written by his widow: in which are these words; "*He was eminently formed to endear himself to his friends and to engage the respect of his inferiors In the discharge of public duty he was active and conscientious without ostentation;*" to the truth of which words the tradition handed down by those who knew him bears ample proof. Sir **C. T. Palmer**, Bart., married on 14th July, 1802, **Harriot**, third daughter of Sir **William Pepperell**, Bart., by which lady, who was left a widow for more than twenty years, he had, with other children, an eldest son, **George Joseph**, afterwards third Bart., the father of the present owner of Wanlip, Sir **Archdale Robert Palmer**, Bart.

WOODHOUSE.

(a)

SILVER GILT CUP. Weight 14.6 oz. Height 8 $\frac{3}{4}$ in. Diam. of bowl 3 $\frac{3}{4}$ in.; of foot 3 $\frac{5}{8}$ in. Height of stem 4 $\frac{7}{8}$ in. Date 1610. (FIG. 6.)

Hall marks. 1. Lombardic N in a pointed shield. 2. Lion passant. 3. Leopard's head crowned; each with an outer line. 4. W. R., two curved lines below, within a shaped shield.

This is a handsome cup having a straight-sided bowl, with a thick stem divided by a very large round knob from whence it swells out into a conical-shaped foot. Upon the bowl are these arms; *Argent, a fess vairé Or and Gules. Crest, a bull's head Argent, attired Sable, gorged with a laurel wreath: Herrick.** Below, is the motto "*Virtus nobilitat.*" The coat of arms divides in half this inscription; "*Gulielmus Hericke Miles Amoris ergo dedit 1610.*"† Upon the foot is; "*For the chappell of Woodhouse in Leicestershire. Wtt. 17 oz. qter. d.*"‡



Fig. 6. 1610. Rather more than half full size. M.P. del.

* For grant confirming this crest, see *Trans. of Lic. Arch. Soc.*, Vol. vi., p. 124.

† "William Hericke, Knight, out of his good will gave this."

‡ 17 oz. and a quarter dwt., I take to be the weight. The cup and paten now weigh slightly more, possibly owing to some small repair. They were regilt at the expense of Mrs. Herrick, in 1778: see *Nichols*, Vol. iii., p. 117.

SILVER GILT PATEN with a foot. Weight 3.5 oz. Diam. $4\frac{1}{2}$ in. Diam. of foot $1\frac{3}{8}$ in. Height of foot $\frac{7}{8}$ in. Date 1610.

Hall marks as on cup.

This paten has a flat edge $\frac{1}{2}$ in. wide, finished off with a few lines, the middle part being sunk flat $\frac{1}{8}$ in. deep. The foot is a disk attached to the paten by a round stem swelling out a good deal towards the paten and a little towards the foot. Upon the foot in a plain shield are the arms of **Herrick**. The paten fits on to the cup with the foot downwards.

(b)

SILVER FLAGON. Weight 27.7 oz. Height 7 in. Diam. at top $4\frac{1}{8}$ in.; at the foot $4\frac{7}{8}$ in. Date 1716.

Hall marks. 1. Capital Roman A. 2. Britannia. 3. Lion's head erased. 4. O. H. in an oblong.

This is a short straight-sided tankard narrowing towards the top, gilt inside. It has a round top to its lid and a handle of the usual shape. About thirty-five years ago a spout was put into the drum at the top. On one side of the drum is this inscription; "*This tankard was given to the chapel of Woodhouse by Thomas Holmes, late of Belton, gent: 1736.*" In front is the monogram of the donor in interlaced letters, by means of which both his christian and surname may be read. The monogram was probably engraved upon this tankard at the time when it first became the property of Mr. **Holmes**, it having been possessed by him for twenty years no doubt.

(c)

SILVER DISH. Weight 14.8 oz. Diam. $9\frac{1}{4}$ in. Date 1806.

London hall marks.

This is a plain basin-shaped dish. In its centre is the sacred monogram with a cross above and three nails below, within a circle of glory. On the back is this inscription; "*For the chapel of Woodhouse, Leicestershire, given by Mary Herrick, A.D., 1834.*"

(a)

The donor of the silver gilt cup and paten, was the 5th, and youngest son of **John Herrick**, ironmonger, of Cheapside, Leicester, who was twice mayor of that borough, by his wife, **Mary**, daughter of **John Bond**, Esq., of Ward End, or Little Bromwich, co. Warwick, and was baptized at St. Martin's, Leicester, on 9th Dec., 1562.* In 1574, **William Herrick**, was started in what proved to be a most prosperous career, by being apprenticed with his elder brother, **Nicholas**, who was established as a goldsmith, at the sign of the "Grasshopper," in Westcheap, London; this **Nicholas** was the father, by his wife, **Julian Stone**, of **Robert Herrick**, the poet. During his apprenticeship, **William Herrick** acted upon his old father's advice, "be a good husband, and save your money," and was in consequence able in about 1590, to start as a goldsmith on his own account, at the sign of the "Rose," in Cheapside, from whence he moved in about 1613, to Wood Street, and subsequently to a house in Westminster; he had a house at

* Parish Register; for extracts from which see *Trans. of Linc. Archi. Soc.*, Vol. vi., p. 118. *Nichols* is in error over **W. Herrick's** age, though it is rightly given on his portrait.

Richmond also, partly no doubt, in order to be near the court. Prospering from the first, **William Herrick** became speedily wealthy, by means of a business combining the trade of a goldsmith, with that of a banker. Amongst his clients were Queen **Elizabeth**, and her successor, together with a host of the aristocracy of that time. As a goldsmith of the period he occupied just such a position as his cotemporary **George Heriot**, the nature of whose business is so well set forth in *The fortunes of Nigel*. In public life, as well as in his trade, the donor of this piece of plate rose to considerable eminence. In 1600, he was elected by the burgesses of Leicester, to be one of their members of parliament, again in 1605 and 1620, during which time his constituents had more than once good reason for styling their member "the townes speciall good frende." At the end of her reign, he was sent by Queen **Elizabeth**, as an ambassador to the Ottoman Porte. On 2nd April, 1605, he was knighted at Greenwich, by King **James**, who also appointed him a teller in the Exchequer, and to an office in the Jewel house. The busy life of a London goldsmith, lessened none of **William Herrick's** love for his native county: on the contrary, the activity of the former was incited by the warmth of the latter; he worked in London, that he might live in Leicestershire; and, as soon as his affairs permitted him, bought an estate in this county, Beaumanor Park; making this purchase in 1594. Here stood a Tudor mansion, formerly belonging to the Marquis of **Dorset**, which was now visited from time to time by its new owner. Early in the reign of **Charles I.**, Sir **William Herrick** seems to have given up his London life, living altogether at Beaumanor; in the great chamber of which house, we are told, four **William Herricks** frequently met together, the knight, his son, grandson and great-grandson. To a man of strong family affections like himself, this pleasant meeting in his last days, we will hope, brought him some comfort in return for the troubles and losses which he sustained at the hands of the so-called Commonwealth. Sir **William** died upon 2nd March, 1652-3, and was buried in St. Martin's Church, Leicester, on the 8th.* Against the North wall, in the North East corner, is a large plain slab to his memory, the inscription on which is given in *Nichols*, Vol. iii., p. 155, but the same author in Vol. i., p. 601, published fifteen years later, mentions this inscription as being then illegible.

Sir **William Herrick** married on 6th May, 1596, at St. Thomas the Apostle's church, Bow Lane, **Joan**, the youngest daughter of **Richard May**, of Mayfield, Sussex, merchant tailor, of London, and owner of property in Mid., East, and West Lavant, Sussex, and elsewhere, by **Mary Hillersden**, a Devonshire lady. By his lady, Sir **William** had seven sons and five

daughters, from the eldest of whom, **William**, was descended the late **William Perry Herrick**, Esq., the munificent founder of St. Mark's church, Leicester. **Joan**, Lady **Herrick**, was born in 1578, and died on 3rd July, 1645. In addition to presenting this cup and paten, Sir **William** repaired the church here, and erected new fittings within it. It is not unnatural to feel some regret, in recording the fact, that much of his work was taken down in 1808, the remainder being altered thirty years ago. The pulpit, however, which he put up, still remains; as well as various texts and inscriptions testifying to his piety, though this is amply borne witness to in the letters written to him by various members of his family. As an example to every successful man of business, of true love and liberality towards his family, native town and church, this worthy knight excels.*

(b)

Thomas Holmes, the donor of the flagon, sprang from a family belonging to Belton in this county.

His wife **Mary** died on 4th April, 1731, and was buried in the nave of Woodhouse church. Mr. **Holmes**, who resided latterly at Quorndon, died without issue on 28th Feb., 1748, aged 83, and was buried by his wife. A slab bearing a short inscription† was placed over their graves, but was removed with others into the tower at the recent restoration.

By his will, made on 22nd Feb., 1747, and proved in Leicester on 29th July, 1749, Mr. **Holmes** left a legacy to his niece **Rebecca Cooper**, and £20 to his servant; his household goods he ordered to be equally divided between his brother **John Holmes**, of Donnington-on-the-Heath, and **Mary Bostock**, of Stanford, Notts.: executors, **William Herrick**, of Beaumanor, and **Thomas Squire**, of Quorndon.

(c)

Mary Herrick, the donor of the alms dish, was the only daughter of **James Perry**, Esq., of Eardisley Park, Herefordshire, and of Wolverhampton, co. Staff., by his wife, **Eleanor Ore**, of Tong, and was baptized at St. Peter's church, Wolverhampton, on 25th of May, 1763. This lady was married at Wolverhampton on 15th Aug., 1793, to **Thomas Bainbrigg Herrick**, Esq., of Gray's Inn,‡ the youngest son of **William Herrick**, Esq., of Beaumanor, who was the great-great-grandson of Sir **William Herrick**, Kt. Mr. **Thomas Bainbrigg Herrick**, was of Merridale, co. Staff., and a D.L. of that county, and died on 24th Sep., 1824, aged 69; his widow, the donor of this dish, survived until 29th Aug., 1836. Both were buried in the family vault in Woodhouse church, their names being commemorated,

* *Vide* Herrick correspondence in *Nichols*, Vol. ii., p. 1614, Vol. iv., p. 150., and in *Trans. Leic. Arch. Soc.*, Vol. v., p. 108.

† For copy see *Nichols*, Vol. iii., p. 117.

‡ *Gents. Mag.*, Vol. lxiii., pt. 2., p. 860.

together with the names of other members of the family, on a mural monument of many coloured marbles affixed to the East wall of the church.

WOODHOUSE EAVES.

SILVER CUP. Weight 10.4 oz. Height $8\frac{3}{4}$ in. Diam. of bowl $3\frac{3}{4}$ in.; of foot $3\frac{1}{4}$ in. Height of stem $3\frac{3}{4}$ in. Date 1838.

Birmingham hall marks.

This cup has a tall straight-sided bowl, and a thin round stem, with a small moulding for a knob. The stem swells out at both ends. The foot is quite plain. In front of the bowl is the sacred monogram with a cross above, within a circle of glory. Upon the foot is this inscription; "*Presented to Woodhouse Eaves Church by Mary Ann Herrick, A.D. 1837.*"

SILVER PATEN with a foot. Weight 12.6 oz. Diam. $7\frac{1}{2}$ in. Diam. of foot $4\frac{1}{4}$ in. Height of foot $2\frac{1}{2}$ in. Date 1838.

Hall marks as on cup.

This is a plain paten with a wide raised edge. In the centre is a sacred monogram as on the cup. Below is a thick round stem, swelling into a flat foot, upon which is the same inscription as that on the cup.

SILVER FLAGON. Weight 23.9 oz. Height 8 in. Diam. at the top $3\frac{1}{2}$ in.; at the foot $4\frac{3}{4}$ in. Date 1838.

Hall marks as on cup.

This is a short straight-sided flagon, narrowing to the top, at which is a spout. It has a round top to its lid and a plain round handle. Upon one side is the sacred monogram as on the cup, and the same inscription round the edge of the foot.

Woodhouse Eaves church was built by subscription in 1837. This service of plate was actually given in the following year; but, since it had possibly been promised in the year the church was built, that year was engraved in the inscription.

The donor of the service was the eldest daughter of **Thomas Bainbrigg Herrick**, by his wife, **Mary**, the only daughter of **James Perry, Esq.**, of Wolverhampton and Eardisley Park, and was born on 9th June, 1796. Many were the gifts made to the church by this benevolent lady; to give an account of them is impossible. The best known examples of her munificence are the almshouses at Woodhouse, built in 1856; a house for the schoolmaster and mistress at Woodhouse Eaves, built in 1860; the infant school in the same parish, built six years later; and the dispensary at Loughborough, built in 1862, at a cost of £5000; the expense of the last two benefactions being shared by her brother, **William Perry Herrick, Esq.**, of Beaumanor. The brother and sister may truly be said to have lived and worked together. Their last notable work was the building of St. Mark's church, Leicester,

the foundation stone of which Miss **Herrick** lived to see laid by her brother. Her useful life was ended a few months before the completion of that work, she dying, unmarried, upon Christmas Day, 1871. She was buried at Woodhouse, in which church, on the South wall of the chancel, is an alabaster monument to her memory, similar to the one to the memory of her brother on the opposite side; and in the North transept of Woodhouse Eaves church are four single-light windows filled with painted glass by the people of this place to the memory of their kind friends, Mr. **W. P. Herrick** and his sister, Miss **M. A. Herrick**; the subjects illustrated in these windows being: 1. The faithful steward; 2. St. Peter holding a model of St. Mark's church, Leicester; 3. Dorcas; 4. Parable of the leaven.



"Then all the Knights of the Table Round marvelled them greatly of Sir Galahad . . . , and said, 'This is he by whom the Sangreel shall be achieved.'"

"Then came King Arthur unto Galahad, and said, Sir, ye be welcome, for ye shall move many good Knights to the quest of the Sangreel, and ye shall achieve that never Knights might bring to an end."

DEANERY OF CHRISTIANITY.

LEICESTER:

ALL SAINTS'.
CHRIST CHURCH.
TRINITY CHURCH.
ST. ANDREW'S.
ST. GEORGE'S.
ST. JOHN'S.
ST. LEONARD'S.
ST. LUKE'S.

ST. MARGARET'S.
ST. MARK'S.
ST. MARTIN'S.
WYGGESTON'S HOSPITAL.
ST. MARY'S.
HOSPITAL OF THE HOLY
TRINITY.
ST. MATTHEW'S.
ST. NICHOLAS'.

ST. PAUL'S.
ST. PETER'S.
ST. JAMES'.
ST. SAVIOUR'S.

KNIGHTON:

ST. MARY MAGDALEN.
ST. JOHN THE BAPTIST.

LEICESTER. ALL SAINTS'.

SILVER CUP. Weight 13.4 oz. Height $8\frac{3}{8}$ in. Diam. of bowl 4 in.; of foot $3\frac{1}{2}$ in. Height of stem $3\frac{1}{2}$ in. Date 1831.

Sheffield hall marks.

This cup has a straight-sided bowl, and a narrow round stem with a plain round moulding for a knob. Its foot has a piece of wood let into it underneath, to give steadiness to the cup. Upon the bowl is "*All Saints' Parish, 1831.*"

SILVER CUP. Weight 13 oz.

Like the first in all respects.

SILVER PATEN. Weight 12.4 oz. Diam. 9 in. Date 1856.

London hall marks.

This is a plain round dish having in its centre the sacred monogram within a circle of glory.

SILVER PLATED FLAGON. Height $10\frac{7}{8}$ in. Diam. at the top $4\frac{1}{2}$ in.; at the foot $7\frac{1}{8}$ in.

Mark. A crown, under the foot.

This is a large straight-sided flagon, made of copper, silver plated. On its side is "*All Saints' Parish, 1831.*"

SILVER PLATED DISH. Diam. $16\frac{1}{2}$ in.

This is a large salver with four feet.

THREE PEWTER PLATES. Diam. $9\frac{1}{8}$ in.

Marks. 1. X crowned. 2. In four small shields, (a) Lion's head erased; (b) Leopard's head crowned; (c) Britannia; (d) S.S. 3. Between two pillars, a hare supporting a garb; above is "*Samuel*;" below, "*Smith, made on Snow Hill, London.*"

Upon the edge of each of these plates is "*A.S.*," for "*All Saints.*" One of these plates was used as a paten until the silver one was given.

FOUR PEWTER BASINS. Diam. $9\frac{3}{8}$ in. Depth $2\frac{1}{2}$ in.

Marks. 1. A rose of five petals crowned, between two sprays of foliage. 2. "London."
Inside each basin is "A.S."

TWO PEWTER BASINS. Diam. $9\frac{3}{8}$ in.

Otherwise exactly like the other four.

These six basins were until recently used for the purpose of collecting the offertory.

From the inventory sent to Archdeacon **Bickham**, we learn that in 1775 there belonged to this parish a silver cup weighing 9 oz. 10 dwts., a pewter flagon, and the three pewter plates mentioned above. The cup and flagon were not here in 1832, and were probably sold when the two silver cups and plated flagon were purchased in 1831. The churchwardens' accounts contain no record of that purchase.

The silver plated alms dish was presented to this church in 1881 by the Rev. **George Ray**, who was then vicar of the parish. In the same year the silver paten was given by an anonymous donor.

LEICESTER. CHRIST CHURCH.

SILVER CUP. Weight 15 oz. Height $9\frac{1}{4}$ in. Diam. of bowl 4 in.; of foot $4\frac{1}{4}$ in. Height of stem $5\frac{1}{8}$ in. Date 1838.

London hall marks.

The bowl of this cup is straight-sided, having the sacred monogram with a cross above and three nails below, within a circle of glory, engraved upon it. The stem has a large knob in its middle, between two smaller ones. The foot, which is hexagonal in shape, is thus inscribed: "*Presented to Christ Church, Leicester, by John Nedham, one of the trustees of the church, 1839.*"

SILVER CUP. Weight 14.6 oz.

This cup is in all respects like the first.

SILVER PATEN with a foot. Weight 19.4 oz. Diam. 9 in.; of foot $4\frac{1}{4}$ in. Height of foot $2\frac{1}{8}$ in. Date 1838.

London hall marks.

This paten is octagonal in shape, having a raised moulding round its edge, on which is the same inscription as that on the cups. In the middle is an eight-lobed depression, with the sacred monogram in the centre.

SILVER PLATE. Weight 16.5 oz. Diam. $9\frac{1}{2}$ in. Date 1838.

London hall marks.

This plate is octagonal in shape, with an eight-lobed depression. In the centre is "*Christ Church, Leicester, 1839.*" and on the edge "*Presented by John Nedham, one of the trustees.*"

SILVER PLATE. Weight 16.1 oz.

Like the last in all respects.

SILVER FLAGON. Weight 51.2 oz. Height $12\frac{1}{2}$ in. Diam. at the top $4\frac{3}{8}$ in.; at the foot $6\frac{7}{8}$ in. Date 1836.

London hall marks.

This is a straight-sided flagon, narrowing a little towards the top. The foot is octagonal in shape, having a raised trefoil upon each of its eight sides. In front, on the drum, is the sacred monogram with a cross above and three nails below, within a circle of glory. Round the edge of the foot is the same inscription as that on the cups.

This church, built by public subscription, was consecrated by the Right Rev. **John Kaye**, Bishop of Lincoln, on 28th June, 1839. In a speech at the luncheon after the ceremony the Bishop thanked Mr. **Nedham** for this gift of his to Christ Church.

Mr. **John Nedham** was the son of **John** and **Anne Nedham** of this town, and was born on 8th March, 1789, being baptized at St. Martin's on the 22nd of that month.* He was educated for the medical profession and gained a wide practice as a surgeon and physician in his native town and county, being for many years senior surgeon to the Leicester Infirmary. He was esteemed by all classes both for his skilful knowledge and kindly disposition, as well as for his devotion to the church and readiness to assist in every good work. He died at his house in Belgrave Gate on 11th Dec., 1855, and was buried in Knighton churchyard. Dr. **Nedham** was twice married: first, to **Harriet**, only daughter of Mr. **Christopher Simmonds**, of Lullington, co. Derby, who died on 2nd Aug., 1820, aged 25,† having borne her husband a son, **John Simmonds Nedham**, who died on 6th Jan., 1851, aged 31;‡ secondly, on 23rd April 1822, at St. Margaret's, Leicester, to **Sarah**, only child of Mr. **James Bankart**, of Leicester,‡ who died on 31st Dec. 1885, aged 88, and by whom Dr. **Nedham** had one son, **Thomas Stanley**, and four daughters, the eldest of whom is the wife of Dr. **T. W. Benfield** of this borough.

The chapel on the South of the chancel of St. Martin's, Leicester, records the memory of Dr. **Nedham**, as is told in this inscription cut on a stone near the door: "*This South chapel of St. Martin's Church was restored A.D. 1865, in memory of Mary Ann Nedham, b. 1781, d. 1864, John Nedham, b. 1789, d. 1855, by their sole surviving sister Susannah Sarah Nedham.*"

LEICESTER. TRINITY.

TWO SILVER PLATED CUPS. Height $8\frac{1}{2}$ in. Diam. of bowl $4\frac{1}{8}$ in.; of foot $3\frac{3}{4}$ in. Height of stem $4\frac{2}{3}$ in.

These cups have straight-sided bowls and plain round stems and feet. In front of the bowl of each is the sacred monogram with a cross above and three nails below, within a circle of glory. Underneath the foot of each is "*Trinity Church, 1838.*"

TWO SILVER PLATED CUPS. Height 8 in. Diam. of bowl $3\frac{1}{2}$ in.; of foot $3\frac{5}{8}$ in. Height of stem 4 in.

These two cups are much the same in shape as the two larger ones.

* Parish Register. + M. I. on tablets on East wall of South aisle in St. Margaret's Church, Leicester.

‡ Parish Register

SILVER PLATED PATEN with a foot. Diam. $7\frac{1}{2}$ in. Diam. of the foot $3\frac{7}{8}$ in. Height of foot 2 in.

This is a plain paten, with the sacred monogram cross and nails, within a circle of glory in the centre. Underneath is "*Trinity Church, 1838.*"

SILVER PLATED PATEN. Diam. $8\frac{1}{4}$ in.

In the centre of this paten is the sacred monogram; at the back, "*Trinity Church, 1838.*"

SILVER PLATED FLAGON. Height $11\frac{1}{2}$ in. Diam. at the top 4 in.; at the foot $5\frac{7}{8}$ in.

This is a straight-sided flagon, narrowing towards the top, having on one side the sacred monogram with cross and nails, within a circle of glory.

SIX SILVER PLATED DISHES. Diam. of each $10\frac{1}{8}$ in.

These dishes are used for collecting plates, and are all quite plain in shape.

This church, built by the munificence of **Thomas Frewen, Esq.**, of Cold Overton, was completed in 1838.

LEICESTER. ST. ANDREW'S.

SILVER CUP. Weight 14.8 oz. Height $7\frac{1}{2}$ in. Diam. of bowl 4 in.; of foot 5 in. Height of stem $4\frac{5}{8}$ in. Date **1861**.

London hall marks.

This cup has a globular-shaped bowl, and a hexagonal stem, knob and foot. Upon one of the six lobes of the latter is engraved the sacred monogram.

SILVER PATEN. Weight 3.9 oz. Diam. $6\frac{1}{2}$ in. Date **1861**.

This paten is sunk in the middle in a six-lobed depression, having in its centre within a circle the "*Agnus Dei.*" Round the flat edge is: "*O Lamb of God, that takest away the sins of the world, have mercy upon us.*"

SILVER FLAGON. Weight 20.7 oz. Height $11\frac{1}{4}$ in. Diam. at the top $2\frac{1}{4}$ in.; at the foot $4\frac{1}{8}$ in. Date **1861**.

This is a jug-shaped flagon, of the usual modern shape. Round its middle is: "*Glory be to God on high.*"

This service of communion plate was given to St. Andrew's on the 20th of Feb., 1862, the day upon which the church was consecrated. The donor was the Rev. **John Spittal, M.A.**, the first vicar of the parish, who remained here till 1874; he is now vicar of St. Peter's, Haven Street, Ryde.

LEICESTER. ST. GEORGE'S.

SILVER CUP. Weight 13.1 oz. Height $7\frac{7}{8}$ in. Diam. of bowl 4 in.; of foot $4\frac{3}{4}$ in. Height of stem $5\frac{1}{4}$ in. Date **1870**.

London hall marks.

This cup has a globular-shaped bowl, round which is an engraved band of grapes and vine leaves. Both the stem and foot are hexagonal in shape. The sides of the stem are filled with open tracery; a large hexagonal knob being in its middle. Upon one division of the foot is engraved the sacred monogram.

SILVER CUP. Weight 12.6 oz.

Like the first in all respects.

SILVER PATEN with a foot. Weight 12.2 oz. Diam. $7\frac{7}{8}$ in. Diam. of foot $3\frac{3}{8}$ in. Height of foot $1\frac{1}{2}$ in. Date 1870.

London hall marks.

This paten is basin-shaped, having in the middle a six lobed depression, in the centre of which is engraved the sacred monogram. Round its edge is a band of wheat ears. Its foot is hexagonal in shape.

SILVER BASIN. Weight 9 oz. Diam. $7\frac{7}{8}$ in. Date 1870.

London hall marks.

This basin has a six-lobed depression in its middle, the sacred monogram being in the centre. Round its edge is engraved a conventional band of foliage.

SILVER BASIN. Weight 6.7 oz. Diam. $7\frac{1}{8}$ in. Date 1870.

London hall marks.

This basin is similar to the last, and has a band of wheat ears engraved round its edge.

SILVER FLAGON. Weight 23.3 oz. Height $10\frac{3}{8}$ in. Diam. at the top $1\frac{1}{2}$ in.; at the foot $4\frac{7}{8}$ in. Date 1870.

London hall marks.

This is a jug-shaped flagon, with the sacred monogram in front, and round both the neck and the middle a band of grapes and vine leaves. Its foot is hexagonal in shape.

TWO GLASS CRUETS with silver necks and stoppers. Date 1879.

Birmingham hall marks.

These are plain round glass cruets with bands of a trefoil ornament engraved round their necks and stoppers.

FIVE PEWTER BASINS. Diam. $10\frac{1}{2}$ in. Depth $1\frac{3}{4}$ in.

Marks. 1. X crowned repeated twice. 2. "Superfine hard metal." 3. "Watts and Harton, London."

The principal part of this communion service was bought by subscription in 1870 to replace a service which was stolen out of the church, and which had been in use since the church was built in 1827. The glass cruets were presented by the Rev. H. J. Fortescue vicar of the parish.

LEICESTER. ST. JOHN'S.

SILVER CUP. Weight 14.8 oz. Height $8\frac{3}{4}$ in. Diam. of bowl $4\frac{1}{2}$ in.; of foot 6 in. Height of stem 6 in. Date 1855.

Birmingham hall marks.

This cup has a globular-shaped bowl, rather pointed at the base; the stem and foot being hexagonal. Round the bowl are these words: "*This is my blood,*" vine leaves and grapes being placed in between. Foliage is spread over the stem and foot, and on each of the six lobes of the latter are some of the symbols of our Lord's passion.

SILVER CUP. Weight 14.5 oz.

In all respects like the first.

SILVER PATEN. Weight 6.6 oz. Diam. 7 in. Date 1855.

Birmingham hall marks.

This paten has the text, "*Take, eat, this is my body,*" round its edge. The middle is sunk into a quatrefoil, in the centre of which is the sacred monogram.

SILVER PATEN. Weight 6.5 oz.

Like the last.

SILVER FLAGON. Weight 18.2 oz. Height 11 $\frac{3}{8}$ in. Diam. of the top 2 $\frac{3}{4}$ in.; of the foot 3 $\frac{1}{2}$ in. Date 1855.

Birmingham hall marks.

This is a jug-shaped flagon, having a conical-shaped lid with a cross on the top. Engraved bands of foliage run round its middle.

SILVER SPOON. Weight .6 oz. Length 5 $\frac{3}{4}$ in. Date 1878.

This spoon has a perforated bowl, and a spiral-shaped stem ending in a cross for a handle.

St. John's Church was consecrated on the 6th of Sep., 1854, the funds for building it having been raised principally through the exertions of the late Canon Fry. As far as I have been able to learn this service of communion plate was, with the exception of the spoon, bought out of the general fund raised at that time for this church. It is worthy of remark that it was in this church that Canon Fry principally worshipped, together with the school teachers who lived under his care and instruction.

LEICESTER. ST. LEONARD'S.

SILVER CUP. Weight 12.8 oz. Height 7 $\frac{1}{4}$ in. Diam. of bowl 4 in.; of foot 5 in. Height of stem 5 in. Date 1877.

London hall marks.

This cup has a globular-shaped bowl, and a round stem and foot. In the middle of the stem is a large round knob, upon which, as well as on the foot, there is some engraved ornamentation.

SILVER PATEN. Weight 4.2 oz. Diam. 5 $\frac{7}{8}$ in. Date 1877.

London hall marks.

This paten has an engraved band of four-leaved flowers round its edge.

SILVER FLAGON. Weight 18.3 oz. Height 11 $\frac{1}{4}$ in. Diam. of the top 2 in.; of the foot 3 $\frac{3}{4}$ in. Date 1877.

London hall marks.

This is a jug-shaped flagon, with a lid surmounted by a finial. Round its middle is an ornamental band with a cross in front.

This set of communion plate was bought soon after the present church

of St. Leonard's was built, with offerings made for this purpose. The church was opened for divine worship in 1877.

LEICESTER. ST. LUKE'S.

TWO SILVER PLATED CUPS. Height 8 in. Diam. of bowl, of foot, and Height of stem $3\frac{3}{4}$ in. each.

These cups have straight-sided bowls with bell-shaped lips, and plain round stems and feet. On the bowl of each is engraved the sacred monogram with a cross above, within a circle of glory.

TWO SILVER PLATED PATENS. Diam. 8 in.

These are plain round patens with the sacred monogram in the centre of each.

TWO SILVER PLATED DISHES with feet. Diam. 8 in. Diam. of the foot $3\frac{3}{4}$ in. Height of stem $3\frac{3}{4}$ in.

These dishes are also quite plain in shape, having in their centre the sacred monogram as it is on the cups.

SILVER PLATED ALMS DISH. Diam. $11\frac{3}{4}$ in.

SILVER PLATED FLAGON. Height $13\frac{3}{4}$ in. Diam. at the top $3\frac{3}{4}$ in.; at the foot $6\frac{3}{4}$ in.

This is a large straight-sided flagon narrowing to the top. There is engraved on one side of it the sacred monogram within a circle of glory.

This service of communion plate is kept in a box, on the lid of which is a plate bearing the following inscription, "*Presented to St. Luke's Church, Leicester, by William Hunt, F.P. The Rev. Leonard Addison, B.A., Incumbent, 29th Dec., 1868.*"* The donor of this communion plate who was born in 1814 was the senior partner of the well known firm of **Hunt and Pickering**, Leicester, ironmongers and implement makers. This was by no means Mr. **Hunt's** only gift to this church, in the building and subsequent usefulness of which he took the greatest interest. Funds for carrying on the work of the church in this and other parishes in Leicester were constantly supplied by him. At his death, a painted window was put into the east end of St. Luke's church by Mrs. **Hunt**, to his memory: beneath which is the following inscription: "*To the glory of God and in memory of William Hunt who died April 16th, 1874. This window was erected by his widow.*" It is interesting to know that St. Luke's, built in 1868, was the first new church consecrated in the diocese by the present Bishop of Peterborough.

* Now Vicar of Gretton, Northants.

LEICESTER. ST. MARGARET'S.

(a)

SILVER CUP. Weight 17.3 oz. Height $8\frac{7}{8}$ in. Diam. of bowl $4\frac{3}{8}$ in.; of foot $5\frac{7}{8}$ in. Height of stem $5\frac{3}{4}$ in. Date 1848.

London hall marks.

This cup is a more or less faithful copy of the chalice given by Sir Thomas Pope, to Trinity College, Oxford. It has a deep globular-shaped bowl, and hexagonal stem, knob, and foot. A pierced lozenge-shaped ornament runs up each of the six sides of the stem, and up each angle a small cable moulding. Round the bottom of the stem is an open embattled work of six sides. Round the top of the foot is "*Calicem salutaris accipiam.*"

SILVER CUP. Weight 18.4 oz.

In other respects just like the first.

SILVER PATEN. Weight 4.3 oz. Diam. $6\frac{7}{8}$ in. Date 1844.

London hall marks.

In the middle of this paten is a six-lobed depression; the vernicle being engraved in the centre, and the sacred monogram in each of the six lobes.

SILVER PATEN. Weight 4.2 oz. Diam. $6\frac{7}{8}$ in. Date 1845.

London hall marks.

This paten is of the same shape as the first. In its centre is engraved a cross calvary and the symbols of the crucifixion, and round the edge "*Ipse autem vulneratus est propter iniquitates nostras.*"

(b)

SILVER GILT FLAGON. Weight 26.7 oz. Height $12\frac{1}{2}$ in. Diam. at the top $1\frac{3}{4}$ in.; at the foot $5\frac{7}{8}$ in. Date 1851.

London hall marks.

This is a jug-shaped flagon with a hexagonal-shaped foot; round the middle is: "*Pascha nostrum immolatus est Christus;*" and round the foot: "*In usum ecclesie S. Margarete apud Ratas dedit Michael Scymour Edgell, Vicarins, 1852.*"

There formerly belonged to this parish an interesting series of churchwardens' accounts the whereabouts of which is not now known. Extracts were made from them in 1729 by Mr. Peck, including entries made from 1553 to 1573. These extracts are given in Nichols' *Hist. of Leic.*, Vol. i., p. 560.

The following are some of them:—

	£	s.	d.
* "1553. For a patten to the Chales	0	11	3"
† "1554. For making Serch for the Chales	0	2	4"
"1568. Received for the Chales.....	4	13	4"
"—— Paid for the Com'union Coppe	4	8	0"

The next documentary evidence relating to the communion plate here is that contained in the terrier of 1712, which describes the service thus: "A pewter flagon; two pewter plates to gather the offertories; two silver chalices,

* Same sum was given two years later for a paten for St. Martin's.

† It had perhaps been parted with in the former reign and was now ordered by the Commissioners to be recovered.

with two covers to them, weighing 24 oz., without inscription." From the terrier of 1724 we learn that this communion service had by that time received three additional pieces; it is described in that year as follows: "A pewter flagon; two pewter plates to gather the offertory; two silver chalices, and one little silver chalice for the use of sick persons who are desirous to receive the holy sacrament at home; a silver strainer; a silver salver for the bread; the weight of the whole 49 oz. 9 dwt."

The cup, bought in 1568, which weighed about 15 oz., may or may not have been one of these mentioned in the terriers; I am inclined to think it was not: in any case it does not seem to have been here when the new service was bought, since the Rev. **W. H. Anderdon**, at that time vicar of this parish, assures me that though he cannot remember clearly of what pieces the old service consisted, every piece was of the plainest possible design. Amongst those pieces, this gentleman tells me, were one or more silver tankards and at any rate two cups.

One silver flagon recently here had been purchased with a legacy left for that purpose by Mrs. **Thompson**, of Evington, a lady closely connected with this parish, who placed in her will, proved in 1737, this clause: "*I order my executors after named to lay out £15 in a silver flagon which I give as communion plate for St. Margaret's Church, Leicester.*"*

Since this church was only recently placed under the jurisdiction of the Archdeacon of Leicester its communion plate is not mentioned in Archdeacon **Bonney's** inventory.

(a)

The whole of the old service was sold in 1848, at which time the two modern cups with their patens were bought with the proceeds of that sale and some voluntary subscriptions in addition.

(b)

The donor of the flagon, the Rev. **M. S. Edgell**, was vicar of this parish for rather more than a year. He is now vicar of Swanley, Kent.

LEICESTER. ST. MARK'S.

SILVER GILT CUP. Weight 12.8 oz. Height $7\frac{1}{8}$ in. Diam. of the bowl 4 in.; of the foot $4\frac{3}{8}$ in. Height of stem $4\frac{1}{2}$ in. Date 1871.

Birmingham hall marks.

This cup has a short bowl in the shape of an inverted truncated cone, with a flat base; and a round stem half an inch thick, having in its middle a thick round knob with six carbuncles set in it. The foot is shaped in six lobes, with a carbuncle set in the middle of each. Round the lower part of the bowl, and also round the knob, are vine leaves and grapes chased in relief. Up the stem is engraved a four-leaved flower within lattice work. Underneath the foot is a plate with this inscription on it: "*St. Mark's Church, Leicester, 1872.*"

* Vide Evington.

SILVER GILT CUP. Weight 12.7 oz.

This cup is very slightly shorter than the first, but is in other respects the same.

SILVER GILT PATEN. Weight 4.9 oz. Diam. $6\frac{1}{2}$ in. Depth $\frac{7}{8}$ in. Date 1871.

This is a basin-shaped paten, with a flat edge one inch wide, round which are these words: "*The bread of God is He which cometh down from heaven, and giveth life unto the world.*" In the centre, within a quatrefoil, is the winged lion with "St. Mark" below. Underneath the paten is: "*St. Mark's Church, Leicester, 1872.*"

SILVER GILT PATEN. Weight 4.8 oz.

Round the edge of this paten is: "*Jesus said, I am the living bread which came down from heaven.*" In other respects it is the same as the first.

SILVER GILT BASIN. Weight 12.6 oz. Diam. $9\frac{1}{4}$ in. Depth $1\frac{3}{8}$ in. Date 1871.

Round the edge is: "*The bread which we break, is it not the communion of the body of Christ.*" In the centre is the same device as that on the patens, and on the back the same inscription.

SILVER GILT FLAGON. Weight 22.3 oz. Height $10\frac{1}{2}$ in. Diam. at the top $2\frac{1}{8}$ in.; at the foot $4\frac{1}{4}$ in. Date 1871.

This is a jug-shaped flagon with a cross on the top of the lid, in the middle of which cross a carbuncle is set on both sides. Round the neck of the flagon are five carbuncles set in an engraved band of quatrefoils. This text runs round its middle: "*The cup of blessing which we bless, is it not the communion of the blood of Christ.*" The foot is shaped into six lobes, with a carbuncle in the middle of each.

It is hardly necessary to say that the donor of this handsome service of communion plate was **William Perry Herrick**, Esq., who, with his sister Miss **Mary Ann Herrick**, founded this church. Mr. **Herrick** was the eldest son of **Thomas Bainbrigge Herrick**, by his wife **Mary**, the only daughter of Mr. **James Perry**, of Wolverhampton, and Eardisley Park, Herefordshire, and was born on 29th June, 1794.* He graduated from University College, Oxford, as B.A. in 1815, and M.A. in 1821, and was afterwards called to the bar. Upon the death of his uncle, **William Herrick**, Esq., in 1832, he succeeded to the ancient inheritance of his family, Beaumanor Park, in this county, and upon the death of his maternal uncle, **Thomas Perry**, Esq., of Eardisley Park, he inherited a large fortune, together with property in Staffordshire, Wales, and Hertfordshire, in addition to the Eardisley estates: in accordance with the will of his uncle, he added the name and arms of **Perry** to his own. His was certainly a life made happy, with the loan of the four things sung of thus by the poet of his name and race:—

"Health is the first good lent to men;
A gentle disposition then:
Next, to be rich by no by-ways;
Lastly, with friends t' enjoy our days."

* See Woodhouse, p. 72.

In most public affairs Mr. **W. Perry Herrick** took but a small part; he was high sheriff of the county in 1835, but seldom acted as a justice of the peace, much less did he make any attempt to enter parliament; he found many other ways of rendering useful service to his neighbours. As a churchman, he took the lead in many a good work, promoting especially, together with his friend Earl **Howe**, the work of the Church Extension Society, of this county, started by Canon **Fry**. His liberality helped to build several of the new churches in Leicester; and looking nearer home, we find him restoring his own parish church at Woodhouse, in 1858, at a cost of £600, and repairing the tower of Loughborough church, in 1862, at a cost of £1000. His great work was the building of this church of St. Mark, which he commenced together with his sister, and finished after her death. The foundation stone was laid by Mr. **Herrick**, on 18th May, 1870, at which time he said these words, well worthy of being remembered;

"I hope I may be allowed to express my gratitude to Almighty God, that, whilst many valued and excellent men, who would have rejoiced to have been present this day, have been taken away from us, I have been spared to lay this foundation stone; and I trust the blessing of God may rest upon the work which is now begun; undertaken as it has been, with an humble endeavour to promote the glory of God, and the salvation of our fellow-men.*"

This church, built at great cost, was consecrated upon St. Mark's day 1872. Together with the church Mr. **Herrick** built schools and a vicarage house; the living was also endowed by him. On 13th August, 1862, Mr. **W. P. Herrick** married **Sophia** the youngest daughter of **J. H. Christie**, Esq., of Lincoln's Inn, barrister, and of Hyde Park, London, which lady survives her husband and admirably carries on his good work. Mr. **W. Perry Herrick** died without issue upon 15th Feb., 1876, and was buried at Woodhouse; in the chancel of which church, on the north side, is an alabaster mural monument to his memory surmounted by his arms.

Quarterly 1 and 4 Argent, a fess vairé Or and Gules, Herrick; 2 and 3 Barry of six Or and Gules, on a bend indented Argent three lions passant Sable, two flanches Ermine, Perry. Crests 1. A bull's head Argent attired Sable gorged with a laurel wreath, Herrick. 2. A hind's head erased proper, semé of annulets Or, in the mouth a pear tree branch slipped proper, fructed Or, Perry.

LEICESTER. ST. MARTIN'S.

(a)

SILVER CUP WITH COVER PATEN. Weight of cup 10.3 oz. Height 7½ in. Diam. of bowl 4½ in.; of foot 4⅜ in. Height of stem 3½ in. Date 1662.

Hall marks. 1. Capital old English E in a plain pointed shield. 2. Lion passant. 3. Leopard's head crowned; each of these two latter having an outside line following their outline. 4. M badly formed, with a mullet below, within a heart-shaped shield.

* See *Leicester Advertiser*, Feb. 1876.

This cup has a straight-sided bowl with a bell-shaped lip and a flat base. Its stem gradually swells out into a plain round foot. The bowl is beaten out of one piece of metal, the stem and foot out of another. It is the same in shape as the cups belonging to St. Mary's, though not so large in size.

SILVER COVER PATEN with foot. Weight 4.2 oz. Diam. $5\frac{1}{4}$ in. Diam. of foot $2\frac{1}{2}$ in. Height of foot $\frac{7}{8}$ in. Date 1662.

The hall marks are very indistinct, the only one of the four which has been properly struck being the maker's mark as on the cup. The official of the goldsmith's company seems to have been somewhat "distract" while he was handling the punches. The lion passant has apparently been struck on the top of the annual letter: and in the place where the leopard's head should be the maker's mark has been struck twice.

This paten is of the same flat shape as most others of this date. The foot is a disk, attached to the stem by a straight round stem.

(b)

SILVER CUP WITH COVER PATEN. Weight of cup 12.1 oz. Height $8\frac{1}{2}$ in. Diam. of bowl $4\frac{1}{8}$ in.; of foot $3\frac{7}{8}$ in. Height of stem $3\frac{7}{8}$ in. Date 1709.

Hall marks. 1. Court hand O. 2. Lion's head erased. 3. Britannia. 4. Capital old English R and a small Roman E, in a plain pointed shield.

The bowl of this cup is, in shape, an inverted truncated cone. The stem is thick, swelling out a little towards both its ends; round its upper part is a small moulding for a knob. Mouldings run round the foot of this cup, underneath which the lion's head erased is repeated. This inscription is engraved round the top of the stem: "*The gift of Eliz. Coates, for the use of the Parish Church of St. Martin in Leicester, 1710.*"

SILVER COVER PATEN with foot. Weight 6.5 oz. Diam. $5\frac{1}{4}$ in. Diam. of foot $2\frac{3}{8}$ in. Height of foot $1\frac{1}{2}$ in. Date 1709.

Hall marks as on the cup.

This cover paten is of much the same shape as the one belonging to the other cup.

(c)

SILVER PATEN with a foot. Weight 11.8 oz. Diam. $8\frac{3}{8}$ in. Diam. of foot $3\frac{1}{2}$ in. Height of foot 2 in. Date 1719.

Hall marks. 1. Capital Roman D in a plain shield. 2. Britannia. 3. Lion's head erased. 4. Capital Roman L and small I with a pellet below, in a shaped shield.

This paten is quite plain in shape, having a raised moulding round its edge, and some round mouldings round the edge of its hollow foot. Underneath is this inscription: "*Deo and Eccl. S. Martini Leicestr. D.D.D. Tho. Noble Arm. Burgens parl. unius 1719.*"*

SILVER PATEN with a foot. Weight 11.7 oz.

In all other respects exactly like the first.

* To God and the church of St. Martin, in Leicester, Thomas Noble, Esq., a burgess in parliament gave and dedicated (this) as a gift.

(d)

SILVER PLATE. Weight 13.1 oz. Diam. $9\frac{1}{8}$ in. Date 1758.

Hall marks. 1. Capital old English C in a square shield. 2. Lion passant in a plain oblong. 3. Leopard's head crowned in a rounded shield. 4. C. T. W. W. in an oval: the mark of *Thomas Whipham* and *Charles Wright*.

This plate, which was evidently made for a dinner plate, has a flat edge, round which is engraved a narrow band of conventional foliage, in which are two blank spaces on opposite sides of the plate, for a crest or monogram. On the back is this coat of arms: *Argent two bends Gules*. Crest: *A demi panther gardant Argent spotted Azure, Or and Gules holding a branch Vert flowered of the fourth*; **Hacket**. (FIG. 7.)

Below the arms is: "*Ædi Leicestriensi Divo Martino Sacra Vas hoc Argenteum non nisi apud Altare utendum Philippus Hacket curiæ ecclesiasticæ Procurator dono dedit 1762.*"*



Fig. 7.

SILVER PLATE. Weight 13.1 oz.

This plate is just like the last, with the exception of its having this shorter inscription upon it: "*Donum Philppi † Hacket curiæ ecclesiasticæ Procuratis 1762.*"

(e)

SILVER FLAGON. Weight 46.2 oz. Height $12\frac{3}{8}$ in. Diam. at the top 4 in.; at the foot $6\frac{3}{4}$ in. Date 1711. (PLATE 8.)

Hall marks. 1. Court hand Q. 2. Lion's head erased. 3. Britannia. 4. S.L. with a pellet below, in a shaped shield: the mark of *Gabriel Scath*.

This is a straight-sided flagon, narrowing a little towards the top. Its lid rises up, in two flat stages, to a small knob. In front, at the top, is a spout, which is by no means commonly found in flagons of this date. This spout is covered by a little flap attached to a hinge, so that when the lid of the flagon is closed, and also this flap over the spout, both flies and dust are rigorously excluded. Within an ornamental oval in front of the drum is: "*St. Martin's, Leicester*;" and underneath the foot is: "*The gift of Alice, widow of John Barne, of London, daughter of Edward Billers, formerly of this Parish, 1711.*"

SILVER FLAGON. Weight 45.7 oz.

This flagon is like the first in all respects. The little flap is no longer attached to its spout, having evidently been broken off many years ago, which is perhaps just as well, for a large dint has been made in the lid of the other flagon by the point of the flap running into it when put back.

(f)

SILVER ALMS DISH. Weight 54.9 oz. Diam. $15\frac{1}{4}$ in. Depth $1\frac{1}{2}$ in. Date 1783.

* Philip Hacket, Proctor in the Ecclesiastical Court, gave as a gift this silver vessel to the church in Leicester, sacred to St. Martin, to be used only at the altar.

† The second I has evidently been omitted by a mistake of the engraver.

Hall marks. 1. Small Roman H in a square shield. 2. Leopard's head crowned, in a rounded shield. 3. Lion passant in a plain oblong. 4. I.S. I.B. in an oblong. Mark of *James Sutton* and *Joseph Bult*.

This is a large plain alms-basin, with a raised moulding round the edge, and in its centre a raised boss, 5½ inches in diameter. Underneath the dish is this inscription:

"*The Rev^d. Thomas Haines, Vicar.*

William Capf }
John Eames } *Churchwardens 1784.*"

The following entries in the churchwardens' accounts of this parish which date from 1489, have something to tell us about some of the pieces of church plate belonging formerly to St. Martin's.*

"1492. For mending the silver candlestick	20 <i>d</i> ."
"1544. P ^d to Robard Goldsynth for mēding the pix	iiij <i>d</i> .
" P ^d to Robart Goldsynth for mēding the chalis belong- yng to sent georgs chapell and a pix	xv <i>d</i> .
"1545-6. Plate solde. R ^d of Mr. tallance then maire of covetre the xj th day of auguste for s'ten plate sold to hym as apperith by hys p̄ticuler byll therof sm'	xxiii <i>li</i> . vs. x <i>d</i> .
" Item pd in expences ij dais at covetre when we sold the plate there for ovr horses and owre selves	iijs. j <i>d</i> ."

No "p̄ticuler byll" has been preserved so we do not know what the "s'ten plate" was that was sold to the mayor of Coventry. I imagine it chiefly belonged to the chapels within this church.† In the year before, 1545, all chapels, chantries and fraternities were given by a vote of parliament to **Henry VIII.**‡ So it seems that the good people of St. Martin's were determined to be beforehand with their King by turning this "portable property" into cash; they thinking it but too probable that he would, when he suppressed the chapels, seize their plate.

"1546-7. Itm. pd for mendynge the vyse of a sylv' candylstyke to Robt. Goldsynthe.....	vii <i>ij</i> <i>d</i> ."
"1551-2. Reseyvd for a crowne of wood kyverd w ^t sylv' and ij croses of wode kyverd w ^t sylv' and a notte of copper	ii <i>ij</i> <i>li</i> . vjs. viii <i>d</i> ."
"1554-5. Itm. pd to Robert goldsmyth for a pattyn of a chalyce	xjs. ii <i>ij</i> <i>d</i> ."

At the beginning of the accounts for 1567-8 the exchange of the chalice for the communion cup is noted as follows:

"M^d sold by Mr. Willm Manbye by thessent of y^e p̄sishe one chales weyinge xv ounce 3 quarters aft vs. ii*ij* *d*. the ounce wth comyth to ii*ij* *li*. iijs. ii*ij* *d*. And also bought by the sayd Mr. Willm Manbye one Comnyon Cupp wth Kever Duble gylyte wayinge xxj ounce and a Half at vjs the ounce wth Comyth to v*li*. ixs., so y^t there Remaynyth to be payd unto y^e sayd Mr. Willm Manbye over and above y^e p̄ce of y^e challs by y^e p̄sishe the some xliiis. viii*d*."

* Edited by the late Thomas North, F.S.A. S. Clarke, Leicester, 1884. † For an account of which, see *Chronicle of the Church of St. Martin*, by Thomas North, p. 38.

‡ *Hist. of the Church of England*. T. V. Short, D.D. 8th Ed., p. 105.

The following entries of later date are worth noting.

" 1599-1600.	Item paid for an Hower glasse and a Pewter dishe for the Communion table	xxij <i>d.</i> "
" 1611-12.	Item paid to Mr. Henry Palmer for beinge p'sented for not haveinge a flagen a tablett in the church for Marriages	vjs. iiii <i>d.</i> xij <i>d.</i>
" 1612-13.	Item payde for a table for the decrees of Marriages	
" 1612-13.	Item given the saide daye and yeare above written by Mr. Thomas Manbie, Maior to the church to Remayne for Ever one pewter flagon."	
" 1620-1.	Given this yeare unto the church by Mrs. Elizabeth Warde one silver and guilte Cupp wayinge eighte ounces, one halfe ounce, and halfe a quarter and delyvered to Mr. Arthur Clarke and Mr. Thomas Gilbert.* Also delyvered the same daie into their hands the olde Communion Cupp w th the kever waighinge twentie and one ounces."	
" 1626-7.	Received from the old churchwardens 3 pewter flagons.† Itm. 2 silver and gilt bowles and one silver cover."	
" 1638-9.	Payd to Thomas Redlye for a stander to sett the dish on at the Communion	3 <i>s.</i>
" 1638-9.	Payd to John Launder for a dish for the offeringes at the Communion.....	3 <i>s.</i> 4 <i>d.</i> "
" 1641-2.	Pd to Tho. Pilkington for a new flagon and changing an old one	11 <i>s.</i> 6 <i>d.</i> "

The Elizabethan silver cup and cover and the silver cup given by Mrs. Warde disappeared during the civil wars; perhaps at the time of the capture of the town by Charles on 31st May, 1645. The two pieces may have been plundered by the soldiers who robbed "the poor men's box" in this church; or they may have been parted with to help to raise the £2000 then levied by the King upon the town.

Possibly some of the pewter pieces survived, judging from this record of the church plate in a terrier dated 1714,‡ evidently a copy, word for word, of the terrier made in 1709.

"A silver chalice weighing 10 oz. 12 dwts. and a patten 4 oz. 7 dwts. without any inscription; two pewter flaggons; a pewter platter inscribed thus, 'This belongeth to St. Martin's Church, Leicester, A Dni. 1677;' two pewter dishes to collect the offerings in."

Archdeacon Bickham's inventory of 1775 includes all the silver pieces now here, except the alms dish and "one pewter dish."

Thomas Manby, the donor in 1613 of the pewter flagon once here, was elected mayor of Leicester on 29th Sep. of that year.

Elizabeth Warde, the donor in 1620 of the silver gilt cup formerly here was the daughter of William Morton, thrice mayor of Leicester, and was baptized at St. Martin's on 7th April, 1568.§ She was married in the same church on 12th June, 1587, to William Warde.§ This lady, by deed dated 18th June, 1628, was a benefactress to St. John's and Trinity Hospitals, Leicester.¶

* Churchwardens.

† The origin of two of these not mentioned in the accounts.

‡ Printed in *Nichols*, Vol. i., p. 594.

§ Parish Register.

¶ *Nichols*, Vol. i. [118] [131]

(a)

Extracts only now exist of the churchwardens' accounts from 1645-1737: no record is to be found in these of the gift or purchase of the oldest cup and cover paten now here.

(b)

There is a doubt as to the identity of **Elizabeth Coates**, the donor in 1710, of the other cup and cover paten. I am inclined to think that it was provided in accordance with verbal instructions given, at the time of her death, by a certain **Elizabeth Coates**, who was buried here on 22nd Nov., 1708, aged 61.*

In her will, made 10th Nov., 1708, and proved P.C.C. 2nd Dec., 1708, **Elizabeth Cotes**, of the borough of Leicester, spinster, left £10 to **Elizabeth Southwell**, "daughter of my cousin" **Richard Southwell**, clerk: £5 to **Margaret Kilpin**, spinster, daughter of Mr. **John Kilpin**. All else to "niece" **Elizabeth Miles**, her sole executrix.

(c)

Thomas Noble the donor of the two patens was the representative of a family owning land at Rearsby, co. Leicester, since the first year of **Elizabeth**,† being the eldest son of **Thomas Noble**, of Rearsby, by **Susanna** his wife. In early life he settled in Leicester where his great uncle **Francis Noble**, twice mayor of that borough, was established as a woollen draper. **Thomas Noble** practised as an attorney and became one of the leading inhabitants of Leicester. On 24th April, 1689, he was appointed solicitor to the corporation, and on the death of **James Winstanley** in Jan. 1719, the burgesses of Leicester elected their corporation solicitor to be one of their members of parliament, which honourable office he filled until the next election in 1722. In about the latter year he purchased an estate in Huncote, having inherited the ancient family property at Rearsby from his father. Mr. **Tho. Noble** died on 3rd May, 1730, aged 74, and was buried in the chancel of Rearsby church on the 6th, where there was a slab bearing a short inscription over his grave since moved into the tower. He was twice married; first to **Mary Harvey** of Lincolnshire, and secondly on 13th Oct., 1702,‡ to **Margaret**, eldest daughter of Sir **William Keyte**, of Ebrington, co. Gloucester, Bart., who died on 3rd March, 1710-11, aged 46, and was buried at Rearsby on the 10th, where there was a slab to her memory in the chancel, which is now under the tower. By his first wife Mr. **Noble** had with two daughters, a son, **Thomas**, who dying a bachelor on 8th Feb., 1743, devised his estates to **Thomas Ruding** of Westcotes.

Mr. **Noble** bore these arms; *Argent on a chief Gules a lion passant Or.* Crest. *An eagle displayed Or.*

* Parish Register. † See *Nichols*. Vol. i., p. 616, and Vol. iii., p. 390. ‡ *Burke's Extinct Baronetcies*.

(d)

Philip Hacket the donor of the two silver plates, sprang from an ancient family settled at Minn Court, Lancashire, and at Penterry, Monmouthshire. The **Hackets** became connected with this county through the donor's great uncle and grandfather, **Philip** and **John**, marrying two daughters and co-heirs of **John Danvers** of Thrussington; which matches brought much money into the family, which soon however took to itself wings. The donor was the third son of the Rev. **Philip Hacket**, rector of South Croxton, vicar of All Saints', Leicester, and confrater of Wyggeston's Hospital, by his wife **Jane** the daughter of the Rev. **James Holder**, and was born on 6th May, 1708. Mr. **Philip Hacket**, as the inscription on his gift tells us, practised for many years as a proctor in the ecclesiastical court of the archdeaconry of Leicester: in Archdeacon **Bickham's** inventory he is called one of the "exercent" proctors. Mr. **Hacket** was for upwards of thirty years parish clerk to St. Martin's. He married on 28th Oct., 1725, at St. Michael's church, Stamford, **Elizabeth*** the daughter of **Thomas Hacket** of Wykeham, and had by her three sons, the eldest of whom, **Philip**, became rector of South Croxton, and wrote for Mr. **Nichols†** an amusing and interesting account of his family, making however no mention of his father and mother. Mr. **Hacket** was killed by a fall from his horse on 16th Aug., 1770, and was buried in the south porch of St. Martin's church; a large slate slab to the memory of himself and his two sons **Charles** and **Thomas**, now stands against the east wall of the south aisle. His widow **Elizabeth** was buried at St. Martin's, on 20th Feb., 1772, aged 63.‡

We learn from the churchwardens' accounts of this parish, that the gift of these plates was made by Mr. **Hacket** at a parish meeting, held in the church on 21st Dec., 1762.

By his will made 24th Feb., 1767, and proved in Leicester 18th Aug., 1770. **Philip Hacket** left to his son **Thomas** (Proctor), subject to an annuity to testator's wife **Elizabeth**, a house bought of **Richd. Gamble**, grocer, with the garden bought of **Mr. Peck's** executors; land in St. Margaret's Fields bought of **John Garland**, with land bought of **Mr. Thomas Pares**, agent to **Mr. Joseph Cradock**. To his wife **Elizabeth** money due out of office fees, viz., £20 a year, payable by office keeper, **Mr. John Stockdale**, according to agreement; saving £15 once in three years at **Bishop's** visitation. To son **Thomas** the house next one testator lives in, lately bought of **Thomas Gamble**, Attorney, subject to legacy of £50 to son **Charles**, which is either to be paid to that son's wife, **Jean**, or to his creditors. To son **Philip** (clerk) silver cup with coat of arms; all that son's bonds and notes of hand to be returned to him. Son **Thomas**, residuary legatee and sole executor.

(e)

Alice Barne, the donor of the two flagons, was the fourth daughter of Mr. **Edward Billers**, haberdasher, of this parish, by his wife, **Anne**, the daughter of the Rev. Mr. **Dann**, of Mansfield, Woodhouse, who were married at St. Martin's, on 22nd May, 1638.‡ Their daughter, **Alice**, was baptized

* Parish Register.

† See Vol. iii., p. 238.

‡ Parish Register.

at St. Martin's, on 29th April, 1649,* and married, *circa* 1670, Mr. **John Barne**, who was buried at St. Martin's in the Fields, on 27th Mar., 1692.†

By his will made 11th Dec., 1691, and proved P.C.C. 6th June, 1692, **John Barne**, "coat seller in the parish of St. Martin's in the Fields," left to his wife **Alice** an annuity of £60, charged upon land and tenements in Guillon town, in Ash parish, Kent; to his son **George** that property and £300; to his son **John** £600 when 21 years old; to his son **William** £600 at 21; to his son **John** lease of the shop in the Exchange when wife **Alice** leaves off trade, at which time she is to receive £20 a year out of the business; to his son **William** £200 after the death of wife **Alice**; to son **Miles Barne** land in Burrough, co. Leicester, bought of Sir **Robert Smith**, and £200 when 21; to son **Henry Barne** and daughter **Alice Barne** £100 each at 21, and all land, between them, in Burrough, bought of Mr. **Lathieullier**; to nephew **Francis**, son of brother **Robert Barne**, £10 at 21; to Corporation of the Ministers' Sons £10; to parish of Limidge, Kent, £3 for 6 widows; to St. Martin's in the Fields £6 for 12 poor men and women. Brother **Myles Barne**, sister **Anne Gibbard**, sister **Hester Singleton**, brother **Anthony Barne**, sister **Elizabeth Barne**, brother **George Biller**, brother **John Biller**, brother **Francis Biller**, all mentioned. Wife **Alice** residuary legatee and sole executrix; brother **William Barne** and friend **Thomas Vrinster**, overseers.

The date of **Alice Barne's** death I have failed to discover.

(f)

The churchwardens' accounts for the end of last century cannot be found, so that it has not been possible to search for any entry in 1784 relating to the alms dish.

WYGGESTON'S HOSPITAL.

SILVER GILT CUP. Weight 24.5 oz. Height 8 $\frac{3}{8}$ in. Diam. of bowl 4 $\frac{1}{4}$ in.; of the foot 5 $\frac{3}{8}$ in. Height of the stem 4 $\frac{5}{8}$ in. Date 1668. (PLATE 8.)

Hall marks. 1. Capital old English L in a plain pointed shield. 2. Lion passant. 3. Leopard's head crowned, each of the two latter having an outside line following their outline. 4. D G a mullet above and below, within a shaped shield.

This cup, which is remarkably solid, may to some extent be classed with those pieces which belong to the mediæval revival of the 17th century; it has a straight-sided bowl with a flat base, beaten out of one thick piece of metal, below which is a strongly made baluster stem. The foot, which is shaped into eight lobes, is flat on the top, rising up in the middle to meet the stem. Underneath is the lion passant, the same in character as the one on the bowl. Upon the bowl is this coat of arms: *Ermine*,



Fig. 8.

a chevron per chevron Sable and Argent, the upper part charged with three estoiles Or. Crest: A wolf's head erased per pale Azure and Or guttée counterchanged; Wyggeston. (FIG. 8.)

* Parish Register.

† Parish Register.

Above the Arms is "*Hospitū*," on the dexter side "*W̄ill*," on the sinister "*W̄igston*," underneath "*Leicest*."*

SILVER GILT PATEN with foot. Weight 9.7 oz. Diam. $7\frac{1}{2}$ in. Diam. of the foot $3\frac{1}{2}$ in. Height of foot $1\frac{1}{8}$ in. Date 1668. (PLATE 8.)

Hall marks the same as those on the cup.

This paten has a wide flat edge $1\frac{3}{8}$ inches deep, the middle being sunk flat to the depth of $\frac{1}{4}$ of an inch. The foot is plain and hollow, swelling outwards; underneath it the lion passant has been repeated. In the centre of the paten is the coat of arms of the founder, as on the cup. The paten fits on to the cup with the foot downwards.

SILVER FLAGON. Weight 45.5 oz. Height $10\frac{5}{8}$ in. Diam. at the top $4\frac{7}{8}$ in.; at the foot $6\frac{3}{8}$ in. Date 1719.

Hall marks. 1. Capital Roman D in a plain shield. 2. Britannia. 3. Lion's head erased. 4. W 1, fleur-de-lis below, within a shaped shield; mark of *John Wisdome*.

This is a straight-sided flagon, narrowing to the top. It has a round top to its lid, and the usual shaped handle. In front is inscribed: "*Ex dono Johannis Wilkins Armig^{ri}.*"

For full particulars of the foundation of this hospital in 1513 by **William Wigston**, merchant of the staple, **Thomas Wigston**, clerke, and **Roger Wigston**, see *Nichols' Hist. of Leicester*, Vol. i., p. 471.

In 1668 the finances of the Hospital were under the entire control of the Master, in accordance with the statutes drawn up under the sanction of Queen Elizabeth; by one of which he was ordered to keep inventories of all plate and furniture belonging to the Hospital, and to renew such goods from time to time, when necessary, at the cost of the revenues of the Hospital.†

In 1857 a new scheme was drawn up by the Court of Chancery, vesting the management of the Hospital in twenty trustees, who in 1863 erected a new chapel, almshouses, and confraternity on a good site in Westcotes, and, in 1875, large and useful school buildings on the site of the Hospital that had been erected by the founder close to St. Martin's church. The destruction of the old Hospital buildings was most unnecessary; for their preservation need not in any way have hindered the development of the advantages introduced under the new scheme.‡ Such a needless act of destruction can only be coupled with the conduct of the corporation of Leicester, in Jan., 1836, when they sold their maces and all their silver plate, many pieces of which had been given to them by different friends in the past.

There is a little uncertainty as to which of two men named **John Wilkins**, presented the silver flagon to this hospital. In 1719 there was living a famous Leicester character of that name, clockmaker, builder, and engineer, who had been elected an alderman of the borough in 1679, and mayor, for a few months, in 1692. He was one of the thirteen of St. Mary's parish, and was buried in that church on 26th March, 1721, his widow,

* A few years ago a discussion was raised as to whether the field in the arms of the founder of this hospital should be ermine or guttée. Here is a proof of the former bearing being in 1668 considered right. See *Transactions of the Leicester Arch. Soc.* Vol. v., part iii.

† A careful search amongst the documents of the hospital would probably bring to light some of these inventories, and so show what sacred vessels formerly belonged to the chapel.

‡ For account of the efforts made by the Leicester Architectural and Archaeological Society to preserve these ancient buildings, see *Transactions*, Vols. iv. and v.

Catherine, on 3rd June, 1723.* The inscription on the flagon tells, I think, that the gift was not made by this **John Wilkins**, for he would, as I take it, have been styled "alderman," instead of "esquire."

The more likely donor was **John Wilkins**, of Ravenstone, cos. Derby and Leicester. This gentleman sprang from a Cole Orton family of that name, and became wealthy by working coal, and by his marriage, *circa* 1688, with **Rebecca**, third daughter and co-heir of **William Wollaston**, of Shenton, by **Elizabeth**, daughter and heir of Capt. **Francis Cave**, of Ingarsby.† **John and Rebecca Wilkins** had an only child, **Francis Wollaston**, born on 2nd May, 1689, and buried at Ravenstone, on 5th Feb., 1711, in whose memory they founded the hospital in that parish, for alms-women, superintended by a master in holy orders. **John Wilkins** served as high sheriff of Leicestershire in 1694, and was elected M.P. for the county in 1698, and again in 1702 till 1708: he was buried at Ravenstone, on 25th Feb., 1726; his wife, **Rebecca**, died on 7th July, 1718, and was buried on 12th; her will is dated 24th Jan., 1712-13.

By his will ‡ made 5th Feb., 1718-19, and proved P.C.C., with a codicil dated 7th July, 1724, on 14th April, 1727, **John Wilkins** gave all his lands and manors to trustees "for the hospital which my late wife and I have built and endowed in Ravenstone;" subject to certain life annuities, one of which he left to his nephew and executor, **Capt. James Adams**.§

The arms of **Wilkins** are: *Gules two swords in saltire Argent hilts and pommels Or, on a chief of the second three mullets Sable*. Crest: *A demi griffin regardant Gules holding in the dexter claw a sword erect, hilt and pommel Or*.

LEICESTER. ST. MARY'S.

(a)

SILVER CUP. Weight 13 oz. Height $8\frac{1}{2}$ in. Diam. of bowl 5 in.; of foot $4\frac{1}{2}$ in. Height of stem $3\frac{7}{8}$ in. Date 1688. (PLATE 8.)

Hall marks. 1. Small black letter L in a plain pointed shield. 2. Lion passant in a plain oblong. 3. Leopard's head crowned in a circle. 4. I.L., with a pellet between and a fleur-de-lis below, within a shaped shield. According to Mr. **Cripps** the mark probably of *John Jackson*.

This cup has a wide straight-sided bowl with a flat base, resting on a plain round stem, without a knob, which swells a little into a plain foot, underneath which the lion passant is repeated. This cup is remarkably simple both in shape and construction. It is made out of two pieces of silver only; the bowl being beaten out of one piece; the stem and foot out of another.

SILVER CUP. Weight 12.7 oz. Date 1688.

This cup measures very slightly less than the first across its bowl and foot. In other respects it is just the same.

* Parish Register. † *Nichols*, Vol. iii., p. 934. ‡ For which, see *Chester of Chicheley*, Vol. ii., by R. E. C. Waters. § William Adams and Sarah Wilkins married 25th Aug. 1660; Cole Orton Parish Register.

SILVER PATEN with a foot. Weight 7.3 oz. Diam. $6\frac{3}{8}$ in. Diam. of foot $2\frac{1}{2}$ in. Height of foot $\frac{5}{8}$ in. Date 1688. (PLATE 8.)

The only mark upon this paten is the maker's mark, which is the same as that on the cups. It has a flat edge, the middle part within being sunk flat. A few lines run round its edge, and round the edge of its foot. It fits on to the cup with its foot downwards.

SILVER PATEN with a foot. Weight 6.8 oz. Date 1688.

The same as the first.

(b)

SILVER FLAGON. Weight 45.7 oz. Height $11\frac{1}{8}$ in. Diam. at the top $3\frac{7}{8}$ in.; at the foot $6\frac{3}{4}$ in. Date 1722. (PLATE 8.)

Hall marks. 1. Capital Roman G in a square-pointed shield. 2. Britannia. 3. Lion's head erased. 4. B.O. with a bird above, within an oblong rising at the top into a circle. The mark of *John Boothby*, at the sign of the parrot.

This flagon is straight-sided in shape narrowing a little towards the top. Its lid slopes up in a succession of round mouldings, finishing with a small round knob on its top. The handle is of the usual shape. In front of the drum is "*St. Mary, Leicester;*" and underneath the foot "*The gift of Ald^r. Tho. Ludlam, Anno Domini 1723.*"

SILVER FLAGON. Weight 45 oz. Date 1722.

The same as the first.

(c)

SILVER DISH. Weight 13.3 oz. Diam. $9\frac{7}{8}$ in. Date 1687.

Hall marks. 1. Small black letter K in a pointed shield. 2, 3, and 4, as on cups.

This dish has a flat edge $1\frac{1}{2}$ inch in width, the middle part being sunk to the depth of a $\frac{1}{4}$ of an inch. A few lines run round its edge.

(d)

SILVER SPOON. Weight .8 oz. Length 6 in. Date 1874.

London hall marks.

This spoon has a perforated bowl, and spiral-shaped stem with a cross for a handle.

TWO PEWTER DISHES. Diam. 11 in.

Marks underneath, 1. X crowned. 2. Rising out of a ducal crown, a dexter arm embowed, vambraced, the hand holding a spear. 3. "London." 4. In four small shapes, (a) S. H. (b) A fleur-de-lis. (c) A dexter arm holding a spear. (d) Per chevron engrailed three leopard's faces.

These and the following pewter dishes are of the same plain shape; each having a flat edge with an inscription upon it. Upon the edge of these dishes; is "*This plate belongeth to St. Mary's parish church in Leicester. Thomas Coleman, Thomas Orton, Churchwardens, 1779.*"

PEWTER DISH.

Like the first two with the exception of its having these marks instead of the others. 1. X crowned. 2. A rose crowned, with an illegible name below. 3. "London."

TWO PEWTER DISHES. Diam. $10\frac{3}{4}$ in.

Marks. 1. X crowned. 2. Rising out of a ducal crown, an eagle displayed, towards the sun in splendour. 3. "London." 4. In four small shapes, (a) Per chevron engrailed, three eagles' heads erased. (b) An eagle's head erased. (c) Sun in splendour. (d) "B—."

On the edge is: "*This plate, etc., Henry Clark, Jacob Sapcote, Churchwardens, 1785.*"

PEWTER DISH. Diam. 10 $\frac{3}{4}$ in.

Marks. 1. X crowned. 2. Rising out of a ducal crown, a horse's jamb. 3. "London." 4. In four small shapes, (a) S D. (b) A talbot's head erased. (c) A horse's jamb. (d) Per chevron engrailed, three griffins' heads.

On the edge is: "*This plate, etc., Thomas Chatwyn, Thomas Coleman, Churchwardens, 1799.*"

PEWTER DISH.

Like the last, but having different marks. 1. X crowned. 2. Rising out of a ducal crown, a horse's jamb. 3. "London." 4. In four small shapes, (a) "J I." (b) A griffin's head erased. (c) An oval-shaped mark. (d) Per chevron engrailed three griffins' heads erased.

TWO PEWTER DISHES. Diam. 10 $\frac{3}{4}$ in.

Marks. 1. Per chevron engrailed, three talbots' heads erased, with "S Dun —" below. 2. "London."

On the edge is: "*This plate, etc., Thomas Chatwyn, William Sturges, Churchwardens, 1800.*"

This parish is known at one time to have possessed a series of churchwardens' accounts beginning in 1489, as interesting as those of St. Martin's; these, with the accounts of other parishes were sold, as Mr. Kelly tells us in his "*Ancient Records of Leicester*," p. 10, in and about the year 1830, in London. One Parish book, however, which records various facts from 1653 to 1731, has recently found its way back to its rightful owners. This book passed into the possession of the late Mr. Joseph Chawner, for many years a clerk in the office of Messrs. Miles, Bouskell and Place, and was by him bequeathed, in 1886, to the churchwardens of this parish. In it has been entered the names of the parish officers elected from year to year, a statement of their accounts in gross, and occasionally a detailed statement of the churchwardens' expenditure; also a few briefs and various agreements.*

Nichols (Vol. i., p. 309) gives a certain number of extracts from the older portion of the accounts formerly in existence, one of which is as follows:

"1544. At the time of accounts, the church being indebted to the churchwardens £3 6s. 8d., a chalice was given to them to pledge; which chalice was next year sold and the debt discharged."

He does not quote the entries recording the sale of the rest of the pre-Reformation plate, and of the purchase of new plate in the reign of Elizabeth. During the rebellion, this church, in common with the others in the borough, seems to have been deprived of whatever silver communion plate it possessed; vessels of pewter being apparently used henceforth until the year 1663, when, according to the parish book recently recovered, there was

"Paid to Mr. Turville for the communion cup and cover £4 2s. od."

This cup and cover is mentioned, with its weight, 13.8 oz., in the inventory drawn up for Archdeacon Bickham in 1775; it had been parted with however before the making of Archdeacon Bonney's inventory in 1832.

* Copious extracts from this book have been printed in *Trans. of Leic. Archæ. Soc.* Vol. vi., pp. 229, 353.

(a)

The two silver cups and patens now here, are referred to in the following entry made in the parish book lately recovered :

"At a meeting of the Vestrey Octob' ye 8th 1688,

"Mr. Thomas Hartshorn was chosen one of thirteen.*

"At same time too gratyfic Mr. Larence Carter for his grate kindnes in bestoing upon the Church two Comunion Cupes and two plates with seven pound of Mr. Wadland's."

This vote of thanks was, however, scratched out, and evidently not formally carried, for on the next page the election of T. Hartshorn has been re-entered separately, and duly attested by the signatures of the members of the Vestrey then present.

This parish book contains an account of the churchwardens' expenditure in detail for the years 1687 and 1689; their expenditure in 1688 is given only in gross, the amount being £23 19s. 6d., the usual sum spent at that time upon the ordinary expenses of the church, and certainly too small a sum to include the purchase of silver communion plate.

There is little doubt but what the above entry, erased possibly for some trifling reason, gives a true account of the origin of the two silver cups and patens. At any rate one cup and paten must have been provided in accordance with this clause in the will of **Thomas Wadland**, made on 15th Feb., 1687, and proved P.C.C., with a codicil dated 16th Feb., 1687-8, on 3rd June, 1688: "*I devise to the parish church of St. Mary of Leicester £7 to buy a chalice for the decent celebration of the Lord's Supper there.*" The donor was the eldest son of **Thomas Wadland**,† of the Newarke, Leicester, and was born about 1645, and dying unmarried, was buried at St. Mary's on 20th Feb., 1687-8.‡

He left to the poor of this parish and of St. Martin's £5 each; to his brother-in-law, **Lawrence Carter**, whom he appointed sole executor, all his house and landed property, subject to an annuity of £30 to his sister **Isabella Wadland**; also legacies to his cousins **Elizabeth Watts** and **John** and **Richard Wadland**. His nephews **Lawrence** and **Henry Carter** he made residuary legatees.

According to *Nichols*,§ **Mr. Wadland** bore these arms: *On a pale three lions' jambs erased.*

Though the origin of the other cup and paten cannot be defined with such certainty as the first, there is every reason to suppose that they were the gift of **Mr. Lawrence Carter**.

This gentleman lived in the Newarke, and was one of the principal inhabitants of Leicester, for which borough he was elected M.P. in 1688 and 1690. He was the patron and chief supporter of Alderman **John Wilkins**.||

* The vestry was composed of thirteen parishioners who elected new members into their body as vacancies occurred. These thirteen transacted the business of the parish and chose the parish officers.

† "Thomas son of George Wadland, bap. 15th Sep. 1605;" St. Mary's parish register. ‡ Parish Register § Vol. ii., p. 719; where there is a short pedigree. ¶ *Ibid* p. 93.

in his scheme for supplying the town with water pumped up from the Soar.* Mr. **L. Carter** was buried in the chancel of St. Mary's, on 1st June, 1710.† He was twice married: first, to **Elizabeth**, eldest daughter of **Thomas Wadland**, of the Newarke, which lady bore him a son, **Lawrence**, baptized at St. Mary's, 30th Sept., 1671,† afterwards a Baron of the Exchequer; she died 29th Sept., 1671. Secondly, in 1675,‡ to **Mary**, daughter of **Thomas Potter**, of St. Mary at Hill, London, by whom he had several children; she was buried at St. Mary's on 19th April, 1727.†

In his will, made 23rd Aug., 1708, and proved P.C.C. 4th Dec., 1711, **Lawrence Carter** left to his son **Thomas**, subject to an annuity to his wife **Mary**, and portions to his daughters **Anne** and **Mary**, the manor of Huncote, and all houses and lands there, in Narborough, Sharnford, and Ratcliffe Culey; and "all that my mill called Castle Mill," and "all that my water house, cisterns, pipes, engines, waterworks," etc., "together with all my power and authority of laying, continuing and making pipes, engines and cisterns within or near the said borough of Leicester, Newarke of Leicester, Castle of Leicester, and Bishop's Fee, or elsewhere, according to a grant thereof to me made by his late Majesty King James II." To son **Lawrence** £3000, subject to certain charges, and house in the Newarke. To sons-in-law **John Watts**, gent., **Edward Stokes**, clerk, and son **Thomas**, Baron Park, in Desford, land in Glenfield and Forest of Leicester, houses in Market Harborough, Gumley, Barleston, Nuneaton, borough of Leicester, and in the Newarke "late Sutton's," in trust to be sold for payment of debts and legacies. To son **Thomas** lease of chambers in Clements' Inn, with books, presidents and papers. Brother **John Carter**, sister **Ursula Carter**, sister **Potter**, cousins **Henry**, **Susanna**, and **Lucy Carter**, mentioned.

Mr. **Carter** bore these arms: *Gules two lions combatant, Or.* Crest: *A lion's head erased, Or. §*

(b)

Thomas Ludlam in his will, dated 4th Nov., 1742, and proved in Leicester in Feb., 1742-3, made this order respecting his gift to this church; "*whereas in the year 1723, I gave to the parish church of St. Mary, two silver flagons, on which a blank is left for the name of the donor, my will is that my executor shall in three months after my decease cause my name to be thereon indited.*" The donor was a member of a family long connected with this town; the name of **Ludlam** being constantly met with from **William Ludlam**, mayor in 1587, to the present time. He was the son of **Thomas Ludlam**, mercer,|| mayor in 1684, by **Anne**, second daughter of **Edward Billers**, haberdasher of Leicester, and was baptized at St. Martin's on 19th July, 1675.¶ He was elected an alderman of Leicester on 6th June, 1720,** and mayor in 1725. His name appears as one of the thirteen in St. Mary's parish book quoted above, but no record was made in that book of his gift: he died without issue

* *Nichols*, Vol. i., p. 318. † Parish Register. ‡ Licence dated 5th July, *Publica. Harl. Soc.*, Vol. 23, p. 243.

§ As on monument to his son, Lawrence, affixed to North wall of St. Mary's next doorway; the only one to this family now left. For inscriptions on others formerly here, see *Nichols*. Ibid.

|| Married at St. Margaret's, 4th Nov. 1663, he buried at St. Martin's, 16th Sep. 1697, she 16th Dec. 1689.

¶ Parish Register.

** Hall Book.

and was buried in St. Margaret's Leicester, on 2nd Dec., 1742.* **Thomas Ludlam** was twice married: his first wife, **Sarah**, died on 4th Nov., 1713, and was buried in St. Mary's on the 6th, near the altar, where was formerly an inscribed slab over her grave;† his second wife was **Mary**, daughter of **John Bold**, rector of Laughton, co. Leicester, and widow of **Thomas Topp** of this borough, whom he married at St. Mary's, on 22nd Oct., 1724.‡ She was buried at St. Martin's, on 29th Jan., 1738-9, aged 64; her will, dated 16th Nov., 1733, was proved in Leicester 12th Nov., 1742, by her husband, **T. Ludlam**, and son **T. Topp**.

In his will **Thomas Ludlam** "the elder" left £100 for the repair of Holy Trinity Hospital; £200 to the mayor, bailiffs, and burgesses of Leicester, the interest to be spent in apprenticing one boy a year with whom they should think fit, "victuallers always excepted;" £100 to mayor, bailiffs, etc., from the interest of which £1 is to be given to a minister of the church of England for preaching a sermon on almsgiving, on St. John the Evangelist's Day, or six days after, for the benefit of the eight widows of St. John's Hospital above stairs, and one shilling a week to be given to one of the widows to act as nurse to the other seven, remainder of interest to be divided equally amongst the eight.§ To nephew **William Thomas**, clerk, £50; niece **Elizabeth Thomas**, £50; niece **Abigail Bakewell**, £50; nephews **Edmund Ludlam**, **Thomas Ludlam**, **John Ludlam**, **Thomas Beardsley**, **Charles Overing**, **William Ludlam**, **Thomas Ludlam**, latter's brother, £50 each; nieces **Martha Ludlam**, **Sarah Ludlam**, **Isabella Ludlam**, **Susanna Beardsley**, **Ann Ludlam**, £50 each; nephew **John Lee** and his sister **Mary Lee**, £50 between them; niece **Mary Johnson**, annuity of £4 for life; to son-in-law **Thomas Topp**, household goods and diamond ring; to brothers-in-law **Samuel** and **John Bold**, clerks, and "my sister," **Frances Elley**, £5 each;|| to sister **Mary Ludlam**, widow, £10; to "granddaughter" **Mary Topp**, linen: to nephew **Edmund Ludlam**, all rest of land, tenements, and personality, he sole executor. Seal, on a chevron three martlets; crest, a demi dragon holding in paws a key.

(c)

The silver dish is included in Archdeacon **Bickham's** inventory, but nothing is known of its origin. No mention is made of it in the above-quoted parish book.

(d)

The silver spoon is the gift of the Rev. Canon **H. V. Broughton**, the vicar of the parish.

LEICESTER. HOSPITAL OF THE HOLY TRINITY.

SILVER CUP WITH COVER PATEN. Weight of Cup 13.8 oz. Height 8½ in. Diam. of bowl 4¾ in; of foot 4¾ in. Height of stem 3½ in. Date 1685.

Hall marks. 1. Small black letter H in a pointed shield. 2. Lion passant in a plain oblong. 3. Leopard's head crowned in a circle. 4. I. S. a pellet between the letters and a rose below, in an ornamental shape.

* Parish Register. † *Nichols*, Vol. i., p. 318. ‡ Parish Register. § See *Report of Commissioners*, Vol. xvii. p. 39. || For pedigree of Bold, see *Nichols*, Vol. ii., p. 788.

This cup is of much the same character as the two contemporary cups belonging to St. Mary's. It has a wide straight-sided bowl, with a flat base, resting on a thick stem, having a small moulding for a knob. On the bowl is, "*Dono debuit Dna. Margareta Sherman sacro sanctæ Trinitatis Gerontocomio Leicestriæ. A. D. 1686.*"

SILVER COVER PATEN with a foot. Weight 5.4 oz. Diam. 6 in. Diam. of foot $2\frac{1}{4}$ in. Height of stem $\frac{3}{4}$ in.

Hall marks as on the cup, the maker's mark being repeated on the foot.

This is a plain flat-shaped paten with a few lines running round the edge and round the edge of its foot.

This Hospital, which had always its own chapel as now, was founded in the first instance, in 1330, by **Henry**, Earl of Lancaster, whose son **Henry**, Duke of Lancaster, extended the foundation by building the Collegiate Church of St. Mary, in the Newarke, placing under the Dean and Canons of that church the charge of the Hospital. At the dissolution of the college* in 1547 the patronage of the Hospital passed to the Crown, in right of the Duchy of Lancaster. Many benefactors have increased the endowment of the Hospital at different times. In recent years the Mayor of Leicester has been permitted by the Duchy of Lancaster to appoint the inmates.†

The gift of the present chalice and paten is thus recorded on one of the tables of benefactions hung on the West wall of the chapel:

"*Mrs. Margrett Sherman, relict of John Sherman, of the Newark, Leicester, gave one silver communion bowl with a chalice value of seven pounds.*"

The donor was, as I believe, the daughter of **Rowland Dand**, of Mansfield Woodhouse, gent., by his wife **Margaret Savile**, whom he married at Aston, co. York, on 2nd Feb., 1631-2.‡ **Margaret Dand** married, *circa* 1658, Mr. **John Sherman**,§ of the Newarke, Leicester, the eldest son of **William Sherman**, of the Newarke, by his wife **Mary Lassells**; **John Sherman** was born in 1618, and was buried in St. Mary's on 5th Dec., 1675.||

Administration of the goods of **John Sherman** was granted at Leicester on 6th Jan., 1675-6, to **John Dand**, of Mansfield Woodhouse, Esq., **Margaret Sherman**, widow, and **Thomas Wadland**, of the Newarke, gent., for benefit of the widow, and **William, John, Rowland, and Lacie Sherman**,¶ the children of deceased. On a separate deed **Margaret Sherman** renounces all right of administration to "my most kind brother **John Dand**."

Margaret Sherman was living in 1687, in which year **Thomas Wadland** bequeathed to her five guineas.

The arms of **Sherman** are: *Or a lion rampant Sable, charged on the shoulder with an annulet for difference, between three oak leaves Vert. Crest: A sea-lion séjant Argent, gutté de poix, finned Or.*

* The Collegiate church was destroyed before 1590. † For account of this Hospital, see *Nichols*, Vol. i., p. 329.

‡ As is recorded in Mansfield Parish Register.

§ For pedigree of Sherman, see *Public. of Harl. Sec.*, Vol. ii., p. 203; and *Nichols*, Vol. i., p. 504.

|| Parish Register, in which are recorded the baptisms of other children of Will. Sherman, but not that of John.

¶ "Lacie son of Mr. John Sherman living in the Newarke, bap. 20th July, 1666;" St. Mary's Parish Register.

LEICESTER. ST. MATTHEW'S.

(a)

SILVER CUP. Weight 13 oz. Height $7\frac{7}{8}$ in. Diam. of the bowl 4 in.; of the foot $4\frac{7}{8}$ in. Height of the stem $5\frac{3}{8}$ in. Date 1866.

London hall marks.

This cup has a globular-shaped bowl and hexagonal stem, knob, and foot. Round the bowl is engraved "*Drink ye all of it.*"

SILVER CUP. Weight 12.7 oz.

Though lighter in weight this cup is very slightly larger than the first. In all other respects it is the same.

SILVER PATEN. Weight 4.7 oz. Diam. $5\frac{3}{8}$ in. Date 1866.

London hall marks.

This paten is sunk in a six-lobed depression. Round its edge is "*Take, eat, this is my body.*"

SILVER PATEN. Weight 4.5 oz.

Just like the other.

(b)

SILVER FLAGON. Weight 26.1 oz. Height 12 in. Diam. at the top $1\frac{1}{8}$ in.; at the foot 5 in. Date 1866.

London hall marks.

This is a large jug-shaped flagon with a cross for a purchase: one band of grapes and vine leaves is engraved round its neck, another round its middle. The foot, which is shaped in six lobes, has this inscription underneath: "*To the glory of God and in memory of Maria Heard Jones who entered into rest 17th August, 1866.*"

(a)

The two silver cups, together with the two patens, were given to this church, at the time it was opened for divine worship in 1866, by the late Mrs. **Moore**, of Museum Square, Leicester. This lady was **Mary**, the daughter of Mr. **James Walker**; she married Mr. **William Moore**, of Kirby Muxloe, who died on 26th Aug., 1849, aged 60. After a long widowhood Mrs. **Moore** died on 4th March, 1880, at the age of 89. Both she and her husband were buried in Kirby Muxloe churchyard, where a large monument stands over their grave, bearing inscriptions to their memory and to other members of the **Moore** family.

(b)

The silver flagon was given at the same time by Mr. **H. S. Jones**, of Victoria Park Road, Leicester, in memory of his wife, the day of whose death is mentioned in the inscription. The donor of this piece of plate, as a jeweller and silversmith, for a long time conducted in the Market Place of this town a widely extended and prosperous business, from which he retired some years ago.

St. Matthew's was one of several churches built under the auspices of the late much esteemed Rev. Canon **Fry**, formerly of 92, New Walk, who was for many years secretary of the Church Extension Society, as well as of the Archidiaconal Board of Education, of which two valuable organizations he may be said to have been the principal founder. This gentleman was a relative of the donor of the two chalices and patens to this church, he having married in 1839 **Isabella**, the sister of Mr. **William Moore**, they being the children of **John** and **Isabella Moore**, formerly of Kirby Muxloe. Canon **Fry** was born at Mere, Wilts., in 1791, and died in Leicester on the 15th June, 1877, being buried at Kirby Muxloe.

LEICESTER. ST. NICHOLAS.

(a)

SILVER CUP. Weight 16.1 oz. Height $8\frac{1}{2}$ in. Diam. of bowl $5\frac{1}{2}$ in. ; of foot $4\frac{1}{2}$ in. Height of stem $3\frac{3}{8}$ in. Date 1714.

Hall marks. 1. Court hand T in a plain pointed shield. 2. Britannia. 3. Lion's head erased. 4. C. I. with a pellet between the letters, within a heart-shaped shield.

This cup has a deep, wide, and straight-sided bowl with a flat base. The stem, which is rather a short one, is quite straight at the top; lower down is a plain round moulding for a knob; and from thence the stem swells out into a plain round foot with a few mouldings round its edge. The lion's head erased is repeated underneath the foot. On the bowl is "*The gift of Susannah Dean, Widow, to y^e Parish Church of St. Nicholas, Leicester, 1714.*"

(b)

SILVER CUP. Weight 8.3 oz. Height $8\frac{1}{8}$ in. Diam. of bowl 4 in. ; of foot $3\frac{1}{4}$ in. Height of stem 4 in. Date 1736.

Hall marks. 1. Small Roman A in a plain pointed shield. 2. Leopard's head crowned in a plain pointed shield. 3. Lion passant in a plain oblong. 4. F. S. a pellet between the letters and an object below, within a heart-shaped shield. Mark of *Francis Spilsbury*.

The bowl of this cup is an inverted truncated cone having a bell-shaped lip. Its stem is a plain round one, swelling out at both ends; having in its middle a round moulding between two small hollow ones for a knob. The foot has some small round and hollow mouldings round its edge. Upon the bowl is "*The gift of Mr. Will^m. Sutton, for the use of St. Nicholas' Church, Leicester, 1736.*"

SILVER PATEN with a foot. Weight 12.2 oz. Diam. $8\frac{1}{4}$ in. Diam. of foot $3\frac{1}{2}$ in. Height of foot $1\frac{7}{8}$ in. Date 1706.

Hall marks. 1. Court hand L in a plain pointed shield. 2. Lion's head erased. 3. Britannia. 4. P.a. with a pellet below and a ball-shaped mark above, within a shaped oblong. The mark of *Humphrey Payne*.

This paten, which evidently belonged to some other church before being given to this, is quite plain in shape. It has a narrow moulding round its edge. Underneath is the same inscription as that on the last cup.

SILVER FLAGON. Weight 58.3 oz. Height 13½ in. Diam. at the top 4¼ in; at the foot 8½ in. Date 1736.

Hall marks the same as those on the second cup.

This is a large straight-sided flagon narrowing a little towards the top. It has a round top to its lid, a plain round handle, and a wide foot. In front of the drum is the same inscription as that on the second cup. This flagon is kept in a wooden case covered with stamped leather. The two cups have also cylindrical-shaped wooden cases, covered with the same kind of brown leather. No case seems to have been made for the paten.

PEWTER PLATE. Diam. 9¼ in.

Marks. 1. X crowned. 2. "London." 3. A rose crowned within an oval. 4. An eagle with two heads displayed within an oval: round the oval is an illegible name.

This plate has a flat edge 1½ in. wide, the rest being sunk to the depth of ¼ of an inch. Upon the edge is "*St. Nicholas.*"

TWO PEWTER PLATES.

The same in size and shape as the last.

Marks. 1. Per chevron engrailed, three leopards' faces; on an oval escutcheon. 2. "London."

Upon the edge of this plate is "*S. N. B. B., St. Nicholas, Leicester.*" Underneath the plate is "*Thos. Newton, Juno. Smith, Churchwardene, 1772.*"

From the inventories of Archdeacons **Bickham** and **Bonney** we learn that in 1775 and 1832 the church plate here was the same as now.

(a)

The first cup was bought with a sum of money bequeathed for that purpose, with these words, by Mrs. **Dean**, in her will dated 16th March, 1705, and proved in Leicester on 22nd Oct., 1706; "*I give to my said brother-in-law (Mr. Henry Dyson)* the sum of £10 to buy a silver cup, a pulpit cloth, and a cushion for the parish church of St. Nicholas.*" Mrs. **Susannah Dean** was the daughter of Sir **John Harpur**, 2nd Bart., of Calke, Derbyshire, by his wife **Susan West**.† She married the Rev. **James Dean**, who was the son of Alderman **William Dean**, mayor of Leicester, and was baptized at St. Nicholas' church 18th Oct., 1651.‡ The Rev. **James Dean** was, in 1677, appointed to the rectory of the North Mediety in Hallaton in this county, which he held until 1683. He was buried in St. Nicholas' on 30th Nov., 1685.‡ Mrs. **Dean** died on 20th Sep., 1706, in the fifty-third year of her age. Two of her children, **Jane** and **Dorothy**, died before her: another son and daughter survived her, viz., **William Dean** rector of Offord Cluny and Offord Darcy, co. Hunts., and **Susannah**, married at St. Martin's, Leicester, on 17th Dec., 1702,§ to Mr. **Matthew Judd**, widower. The rector of Offord placed over

* "Mr. Henry Dyson and Mrs. Jane Harper married 9th Oct., 1677;" St. Martin's Parish Register

† For pedigree of Harpur, Bart., see *Nichols*, Vol. iii., p. 885, and Vol. iv., p. 839.

‡ Parish Register

§ Parish Register.

his mother's grave in the North aisle of this church a Swithland slate slab: this now stands in the churchyard against the wall on the North side of the church.*

It will be noticed that for some unaccountable reason her executor delayed carrying out Mrs. **Dean's** bequest for eight years.

(b)

William Sutton bequeathed to the churchwardens of St. Nicholas, in his will dated 7th May, 1736, and proved in Leicester in the same year, the sum of £30 to be laid out in communion plate as "*the minister of the said parish shall advise and think most needful for the more fit and decent celebration of the Holy Sacrament of the Body and Blood of our Lord and Saviour Jesus Christ.*" Mr. **W. Sutton** was elected churchwarden of St. Mary's, Leicester, in 1722, and one of the thirteen in 1728. He died at his house in Shambles Lane, without issue, on 13th June, 1736, in the 45th year of his age, and bequeathed, in addition to this sum for communion plate, £240 for the purchase of land for the benefit of the poor in Holy Trinity Hospital, and £70 to buy land for the benefit of St. John's Hospital. He was buried in the vestry of St. Nicholas' church; a large slate slab containing a simple inscription lies over his grave, which memorial we will hope will not be allowed to share the fate of that to the other donor of plate to this church. Mr. **Sutton's** widow, **Rachel**, was buried here on 24th Oct., 1749.†

The bill for Mr. **Sutton's** gift is still in existence, and is as follows:

" Mr. Miles.	£	s.	d.
1736 Dec. 18. One silver Chalice and Cup w ^t 66 oz. 19 pwt. at 7/6	25	2	2
One salver.....12 oz. 6 pwt. at 7/0	4	6	3
Engraving three inscriptions	7	6	
A case for the Chalice.....	1	1	0
Ditto for the Cup	12	6	
	31	9	5

Reid the 23rd Dec. 1736 of Mr. Samuel Miles the sum of thirty pounds in part of this bill;

W^m. Lee.

1737. May 11. Reid of Mr. Johnson the sum of one pound eight shillings in full for the bill above written;

by W^m. Lee."

Endorsed at the back;

"Mr. Lee's receipt for Mr. Sutton's Communion plate 1737."

As may be seen, the flagon is called a chalice in the above bill. The salver, being a second-hand piece of plate, was sold at a lower rate per oz., though its intrinsic value was greater than that of the other two pieces. The churchwardens expended rather more than Mr. **Sutton's** bequest.

* For inscription see *Nichols*, Vol. i., p. 610.

† Parish Register.

LEICESTER. ST. PAUL'S.

SILVER GILT CUP. Weight 20 oz. Height 8 in. Diam. of bowl $4\frac{3}{4}$ in.; of foot $5\frac{1}{4}$ in. Height of stem $5\frac{1}{2}$ in. Date 1872.

London hall marks.

This cup has a bowl shaped like an inverted truncated cone, and a hexagonal stem and foot, there being in the middle of the stem a large hexagonal knob. The foot is shaped in six lobes, on one of which is engraved a cross *bottonnée* within a circle.

SILVER GILT PATEN. Weight 5.4 oz. Diam. 7 in. Date 1872.

This is a plain flat paten, having in its centre a cross similar to that on the cup.

GLASS FLAGON with silver gilt fittings. Height $9\frac{3}{8}$ in. Diam. at the top $1\frac{1}{2}$ in.; at the foot $3\frac{1}{2}$ in. Date 1873.

London hall marks.

This is a jug-shaped flagon made of ruby-coloured glass, having a silver gilt neck, lid, and handle. There is also a silver gilt band round its middle.

St. Paul's is one of the new churches of Leicester, the date of its consecration being 1st Nov., 1871.

LEICESTER. ST. PETER'S.

SILVER CUP. Weight 10.4 oz. Height $8\frac{1}{8}$ in. Diam. of bowl $3\frac{3}{8}$ in.; of foot 5 in. Height of stem $5\frac{3}{8}$ in. Date 1873.

London hall marks.

This cup has a V shaped bowl and round stem, with a large round knob in its middle and a plain round foot. A cross within a circle is engraved on the foot, on which and also on the knob is some conventional foliage.

SILVER PATEN. Weight 4.3 oz. Diam. 6 in. Date 1873.

This paten has a flat edge round which is engraved an ornamental band. In the centre is the "*Agnus Dei*" within a circle.

SILVER CUP parcel gilt. Weight 13.4 oz. Height $8\frac{1}{4}$ in. Diam. of bowl $4\frac{1}{8}$ in.; of foot $5\frac{1}{4}$ in. Height of the stem $5\frac{1}{2}$ in. Date 1881.

Birmingham hall marks.

The bowl of this cup is in shape an inverted truncated cone, the stem knob and foot being hexagonal. Engraved designs are on all parts of the cup.

SILVER PATEN parcel gilt. Weight 4.6 oz. Diam. $6\frac{1}{8}$ in. Date 1881.

This paten has a flat edge, round which is engraved a band of conventional foliage; in the centre is placed a hexagonal-shaped device.

SILVER PATEN parcel gilt. Weight 4.5 oz.

Like the last.

SILVER FLAGON parcel gilt. Weight 20.2 oz. Height $12\frac{3}{8}$ in. Diam. at the top $1\frac{3}{8}$ in.; at the foot $5\frac{1}{4}$ in. Date 1881.

This is a jug-shaped flagon with a cross on the lid. An engraved ornamental band runs round the neck and middle, in the latter is placed on both sides the sacred monogram.

The foot is shaped in six lobes, ornamented in the same manner as the foot of the cup. This flagon having in its original shape been found to be too small, has been enlarged by a piece of metal being put in between the neck and the middle.

The four pieces of parcel gilt communion plate were given to this parish by Mrs. **Hunt**, of Holly Bank, Stoneycate, the widow of Mr. **William Hunt**, the donor of the communion plate to St. Luke's church.*

LEICESTER. ST. JAMES'.

SILVER CUP. Weight 9.5 oz. Date 1880.

London hall marks.

SILVER PATEN. Weight 4.21 oz. Date 1880.

This cup and paten are in shape exactly similar to the first mentioned silver cup and paten belonging to St. Peter's church.

SILVER FLAGON. Weight 20 oz. Height 12 $\frac{3}{4}$ in. Diam. at the top 2 $\frac{1}{2}$ in.; at the feet 4 $\frac{1}{2}$ in. Date 1873.

London hall marks.

This is a jug-shaped flagon with a tall wide neck and a plain round foot. A cross is placed on the lid. An engraved band runs round the middle with the sacred monogram on either side.

These three pieces of communion plate together with the first mentioned cup and paten belonging to St. Peter's were bought by subscription at two different times, all being for the use of St. Peter's church, which was built in memory of Earl **Howe**, and consecrated on 18th April, 1874. When St. James' church, a building at present of a temporary character, was erected in St. Peter's parish, then this portion of the plate originally belonging to St. Peter's was transferred to St. James'. Mrs. **Hunt's** gift of the parcel gilt communion plate enabled this transfer to be made.

LEICESTER. ST. SAVIOUR'S.

SILVER CUP. Weight 15 oz. Height 9 in. Diam. of the bowl 4 $\frac{1}{8}$ in.; of the foot 5 $\frac{5}{8}$ in. Height of the stem 5 $\frac{1}{2}$ in. Date 1876.

Birmingham hall marks.

This is a large cup with an egg-shaped bowl, a narrow stem having a large round knob, and a plain round foot. Round the bowl are two gilt bands; upon the upper one are two crosses, and "*This is my blood.*" The knob is adorned with beaded and cable mouldings gilt. Underneath the foot is "*St. Saviour's Church, Leicester.*"

SILVER CUP. Weight 14.5 oz.

Round the bowl is "*Drink ye all of this.*" In all other respects this cup is the same as the first.

SILVER PATEN. Weight 7.6 oz. Diam. $7\frac{1}{8}$ in. Date 1876.

This paten has a flat edge, the middle part being sunk. Upon the edge is a gilt band, on which, between four crosses at equal distances, is; "*Take, eat, this is my body.*" Under the paten is, "*St. Saviour's Church, Leicester.*"

SILVER PATEN. Weight 5.6 oz.

In all other respects the same as the first.

SILVER FLAGON. Weight 28.8 oz. Height $13\frac{3}{4}$ in. Diam. at the top $2\frac{3}{4}$ in.; at the foot $4\frac{1}{4}$ in. Date 1876.

This is a jug-shaped flagon with a narrow neck and wide middle, ending in a plain round foot. Upon the lid are two upright crosses intersecting one another. Round the middle is an ornamental band, upon which is; "*For the remission of sins.*" Round the neck and also round the foot are ornamental gilt bands. Underneath the foot is engraved; "*1 flagon. 2 chalices. 2 patens. The gift of Anna Maria Burnaby, the wife of the founder, June 21st, 1877.*"

This lady was the daughter of Alderman **John Atkins**, of Halstead Place, Kent, by **Anna Maria** his second wife, only daughter of the Ven. **Andrew Burnaby**, D.D., Archdeacon of Leicester, and was born on 3rd Jan., 1805. She married in May, 1830, at St. Pancras' church, London, her cousin the Rev. **Frederick George Burnaby**, the second son of Col. **John Dick Burnaby**, of Evington, by his wife **Henry Anne**, daughter of Sir **Thomas Fowke**, Bart., of Lowesby. The Rev. **F. G. Burnaby** was born at Billesdon Coplow, which had been rented as a residence for his mother while his father was serving abroad with his regiment, the Grenadier Guards, on 18th Sep., 1803. He was educated at Oakham school, and Caius college, Cambridge, from whence he graduated as thirtieth wrangler in 1827, taking his M.A., in 1830. Having served as curate first to Hoby, and then to Dunsby, co. Lincoln, Mr. **Burnaby** was appointed to the living of Barkestone and Plungar* in 1831, which he held with much profit to both parishes till 1859, when he resigned the latter. He gave up Barkestone vicarage in the year following when he retired to Nursling Mount near Southampton, which he had purchased. Here he lived until 1875 when he made a change in his place of residence by selling Nursling Mount, and buying Asfordby House in this county, situated in the parish of which his great-grandfather the Rev. **Andrew Burnaby**, as well as other members of his family, had been rector; he also bought the advowson which formerly belonged to his family, and the manorial rights of Asfordby. Not that that was the first purchase which he had made in that parish, for in 1858 he had bought a site for a school and master's house and conveyed it to the parish by a deed of gift.

Upon his return into Leicestershire Mr. **Burnaby** set about a work with which his name and his wife's will ever be connected; viz., the building of St. Saviour's church, the foundation stone of which he laid in June 1875. This

* These two parishes had been held by one incumbent since 1721.

large church as well as the vicarage house and schools attached to it he built at the cost of about £20,000, entirely provided by himself; he also endowed the living with the tithe rent-charge of Gosberton, co. Lincoln, purchased for that purpose. This large benefaction to the church in Leicester and many smaller gifts made to the church in other places were all the more creditable to Mr. **Burnaby's** generosity since his fortune, though a good one, was not what would now be called very large. Within a few months of making this gift of communion plate Mrs. **Burnaby** died at Asfordby House, on 15th March, 1878. Her husband survived her until 31st Jan., 1880. Over their graves in Asfordby churchyard, to the North East of the church, is a white marble ledger monument, surmounted by a full length recumbent cross. Their memory is recorded inside the church by a painted window in the South window of the South transept, in which is portrayed the Presentation of Christ in the Temple.

The surviving brothers and sisters of Mr. and Mrs. **Burnaby**, and certain friends and relations, as well as the parishioners and congregation, placed, in Advent, 1880, painted glass in the six lancet windows of the apse of St. Saviour's church, to the memory of the founder and his wife: the subjects of the windows being our Saviour's Nativity, Baptism, Agony, Crucifixion, Resurrection, and Ascension.

Since Mr. **Burnaby** had no children his Asfordby property was bequeathed to his nephew, **J. D. A. Burnaby**, who has since sold it; his estates at Evington passed to his brother **Charles Sherard Burnaby**, Esq., for life, subject to certain annuities.

This communion service was presented by Mrs. **Burnaby** to St. Saviour's church on the day of its consecration.*

KNIGHTON.

(a)

SILVER CUP. Weight 11.8 oz. Height 8½ in. Diam. of the bowl 4¼ in., of the foot 3⅝ in. Height of the stem 3⅝ in. Date 1732.

Hall marks. 1. Capital Roman R in a plain pointed shield. 2. Leopard's head crowned, in same. 3. Lion passant in a plain oblong. 4. W. D. with a rose above, within a trefoil; the mark of *William Darher*.

This cup has a straight-sided bowl, rounded off at the base, and having a bell-shaped lip. Its stem is thick, with a small moulding for a knob in its middle. Upon the bowl is "*Edm^d Cradock, John Seale, Churchwardens, 1732.*"

(b)

SILVER PLATE. Weight 16.5 oz. Diam. 9¼ in. Date possibly 1684.

Hall marks. 1. Small black letter G in a plain shield, very indistinct. 2. Lion passant in a plain oblong. 3 and 4 are quite illegible.

This has evidently formerly been a dinner plate. Round its edge, which is gadrooned, is: "*In usum Altaris Ecclesie Knightoniensis D.D. Edmund Cradock Hartopp, Baronettus, 1839.*"

* For pedigree of Burnaby, see *Hist. of Market Harborough*, by Rev. J. H. Hill, F.S.A., pp. 99 and 334.

(c)

SILVER CUP. Weight 11 oz. Height 8 in. Diam. of the bowl 4 in.; of foot 5 in. Height of stem 5 in. Date 1886.

London hall marks.

This cup has a globular bowl, and a round stem, knob and foot. On the latter is a cross, and this inscription: "*Deo gratias F. E. T. Oct. 24, 1886.*"

(a)

Edmund Cradock, the first churchwarden mentioned on the older silver cup, was the eldest son of **Edmund Cradock**, Mayor of Leicester in 1702, and of **Mary**, his wife. **Edmund Cradock**, the churchwarden, was a J.P. for the county and one of the landed proprietors of Knighton. By his wife, **Elizabeth**, daughter of Alderman **Johnson**, of Leicester, he had a daughter, **Mary**, who eventually became his sole heir; which lady married on 1st Sep., 1745, **Joseph Bunney**, Esq., of the Newarke, Leicester. Their son **Edmund Bunney**, married, in 1777, **Anne Hurlock**, the representative of Sir **John Hartopp**, last Bart. of the old creation, when he took the name and arms of **Hartopp**; he assumed also the name and arms of **Cradock** in the following year in accordance with the will of his uncle, **Joseph Cradock**, who died unmarried. Upon 30th April, 1796, **Edmund Cradock Hartopp** was made a baronet, being the first of the new line. This gentleman also eventually became the heir of his mother's first-cousin, **Joseph Cradock**, Esq., F.S.A., of Gumley, co. Leicester.

(b)

The donor of the silver plate was the eldest surviving son of the above Sir **Edmund Cradock Hartopp**, 1st Bart., by his wife, **Anne**, daughter of **Joseph Hurlock**, Esq., of Fort Marlborough, and was born on 17th May, 1789. He succeeded his father as second Bart. on 10th June 1833, inheriting estates in Freeby, Knighton, Gumley, and Aston Flamville, in this county, in addition to a property in Warwickshire. Sir **E. C. Hartopp** married on 23rd Sep., 1824, the Honble. **Mary Jane Eden**, daughter of **Morton**, 1st Lord **Henley**, which lady died on 12th Sep., 1843, leaving no issue. He himself died on the 3rd April, 1849, and was buried in the family vault at Aston Flamville; upon a monument in which church to the memory of his father and other members of the family there has recently been placed a short inscription to himself. Sir **E. C. Hartopp** was succeeded by his brother Sir **W. E. Hartopp**, 3rd Bart., the grandfather of the present possessor of the title Sir **Charles Edward Cradock Hartopp**, Bart.

The arms of **Cradock Hartopp** are: Quarterly; 1 and 4 *Sable a chevron between three otters passant Argent*; **Hartopp**; 2 and 3 *Per saltire Gules and Argent erusilly and three bears' heads coupé counterchanged*; **Cradock**.

(c)

The modern silver cup was presented by Mrs. **Frances Elizabeth Tidswell**, the mother of the Rev. **S. W. Tidswell**, vicar of the parish, as a thankoffering for an only grandson, whose birthday is 24th Oct.

KNIGHTON. ST. JOHN THE BAPTIST.

SILVER CUP. Weight 11 oz. Height $7\frac{1}{2}$ in. Diam. of bowl 4 in.; of foot 5 in. Height of stem $5\frac{1}{4}$ in. Date 1884.

London hall marks.

This cup is mediæval in design having a V shaped bowl and a hexagonal stem, knob, and foot: on one lobe of the latter is "*In memoriam F. E. B.*" with a latin cross above.

SILVER PATEN. Weight 4.7 oz. Diam. 6 in. Date 1884.

London hall marks.

This is a flat paten with the sacred monogram in the centre; and round the edge, "*In usum ecclesie sancti Johannis Baptistæ Knightoniensis. In memoriam Gulielmi Freer, MDCCCLXXXV.*"

TWO GLASS FLAGS with silver mountings. Height 11 in. Date 1884.

London hall marks.

These are jug-shaped flags, with silver handles, bands and stoppers.

SILVER GILT CUP. Weight 11.5 oz. Height 8 in. Diam. of bowl $3\frac{3}{4}$ in.; of foot 5 in. Height of stem $5\frac{1}{4}$ in. Date 1883.

London hall marks.

This handsome cup has a plain bowl, in shape an inverted truncated cone, and a hexagonal stem, knob and foot. Six precious stones are set in the knob and the same number in the foot, the former being also adorned with trefoils in relief. Under the foot is "*Ad majoram dei gloriam. Wm. J. Freer, Clerk of the Peace, 18th June, 1888.*"

This church, built principally through the munificence of Miss **Sarah Barlow**, of Upper King Street, Leicester, who died on 7th May, 1886, aged 85, was consecrated by the Bishop of the diocese on 17th Sept., of that year; upon which day the silver cup was presented by Miss **Mary Jane Freer**, in memory of her sister, **Fanny Elizabeth**, the wife of Mr. **William Butler**, of Acton Turville, co. Gloucester, which lady died in 1883 aged 44.

The silver paten and glass flags were presented by Mr. **William Jesse Freer**, of Stoneygate, Leicester, one of the churchwardens of this church, in memory of his grandfather, **W. Freer**, Esq., of Stoneygate, for many years Clerk of the Peace for Leicestershire, which gentleman died on 2nd Oct., 1873, aged 72.*

The same donor, Mr. **W. J. Freer**, presented in 1888, the silver cup, recording in the inscription the day upon which he was elected to the office of Clerk of the Peace for the county of Leicester

* For pedigree of Freer, see *Leicestershire Pedigres and Royal Descents*, by Rev. W. G. Dimock Fletcher, p. 139.

FRAMLAND FIRST DEANERY.

BARKESTONE.
BELVOIR CASTLE.
BOTTESFORD.
BRANSTONE.
CROXTON KERRIAL.

EATON.
HARSTON.
KNIPTON.
MUSTON.
PLUNGAR.

REDMILE.
SPRINTON.
SALTBY.
STATHERN.

BARKESTONE.

SILVER CUP. Weight 8.8 oz. Height $8\frac{3}{8}$ in. Diam. of bowl $3\frac{3}{4}$ in.; of foot $3\frac{3}{4}$ in. Height of stem $3\frac{3}{4}$ in. Date 1721.

Hall marks. 1. Capital Roman F in plain shield. 2. Lion's head erased. 3. Britannia. 4. B.A., in shaped oblong. The mark of *Richard Bayley*.

This cup has a nearly straight-sided bowl with a projecting lip, and a thick stem divided in half by a round moulding between two hollows for a knob, from whence it swells out into the bowl and foot, round which latter is an ovolo moulding. On one side of the bowl is the sacred monogram and on the other "*Barkston*."

SILVER PATEN with a foot. Weight 5.2 oz. Diam. $5\frac{3}{4}$ in. Diam. of foot $2\frac{1}{2}$ in. Height of foot $1\frac{5}{8}$ in. Date 1726.

Hall marks. 1. Capital Roman L in plain shield. 2. Leopard's head crowned in plain shield. 3. Lion passant in plain oblong. 4. —B, a mullet below, in lobed shield: first letter illegible.

This is a plain flat paten standing on a hollow foot round the edge of which is an ovolo moulding. In the centre is the sacred monogram.

SILVER PLATED ALMS BASIN. Diam. $8\frac{1}{4}$ in. Depth $1\frac{1}{4}$ in.

In the centre is the sacred monogram, and round the side "*Freely ye have received freely give*."

TWO PEWTER PLATES. Diam. of each $8\frac{7}{8}$ in.

Marks on each. 1. X crowned. 2. Conventional flower on a straight stalk between leaves within an oval; "*Francis*" above "*Pigott*" below. 3. On a scroll "—street, London:" name of street illegible.

The silver paten and the silver plated alms basin were presented by the Rev. **Frederick George Burnaby**,* vicar of the parish at the time when the church was restored in 1840: he at the same time defrayed the cost of engraving the sacred monogram, and executing some small repairs upon the cup.

Mr. **Burnaby** was a liberal benefactor to this parish. In addition to raising a large sum of money for the restoration of the church, he gave £1000 himself for that purpose, and

* *Vide* St. Saviour's, Leicester, p. 107.

afterwards made this further gift, which may rightly be recorded here. The resident rate-paying parishioners agreed to give £400 to the same work, and borrowed for that purpose, that sum from their vicar, who lent it on condition, that they repaid it by degrees without interest, by means of a church rate, levied for several successive years: after the parishioners had repaid the first annual instalment, Mr. **Burnaby** frankly forgave them all the remaining portion of the debt. Nine years later he assisted largely with his purse in enlarging and endowing the schools of this parish.

BELVOIR CASTLE.

The communion service now used in the private chapel belonging to His Grace the Duke of **Rutland**, consists of the following pieces.

SILVER GILT CUP. Height 10½ in. Date 1820.

London hall marks.

This cup has a straight-sided bowl, resting on a baluster stem, and hexagonal foot. On one side of the bowl is engraved the sacred monogram, with a cross and three nails within a circle of glory; on the other these arms; *Or, two bars azure, a chief quarterly of the last and Gules in the 1st and 4th, two fleur-de-lis, and in the 2nd and 3rd a lion passant gardant, all Or; Manners; impaling; Gules on a bend, between six cross crosslets fitchée Argent, an escutcheon Or charged with a demi lion rampant pierced through the mouth with an arrow within a double tressure flory counter flory of the first, a mullet for difference; Howard: The whole encircled with the Garter. Supporters; Two unicorns Argent, armed, maned, tufted and unguled Or. Motto: "Pour y parvenir."* A ducal coronet above.

SILVER GILT PATEN. Diam. 6 in. Date 1820.

This is a plain paten sunk in the middle: in the centre is the sacred monogram, and on the edge the same arms as on the cup.

SILVER GILT DISH. Diam. 6 in. Date 1820.

This is just like the paten with the exception of its being sunk deeper in the middle.

SILVER GILT FLAGON. Height 14½ in. Date 1820.

This is a very large straight-sided flagon bearing on the top of its lid the sacred monogram, and in front of the drum the same arms.

This plain and massive service was bought by **John Henry**, fifth Duke of Rutland, for his private chapel in 1820 to replace the service formerly in use, which was said to have been worth £2,000, and was burnt in the fire which consumed the greater part of the Castle, and many of its valuable contents on 26th Oct., 1816.

In, or soon after, 1752 a certain **John Frisby**,* as executor to the Duke's butler then dead, made a list of the plate at Belvoir, in which the communion service of that day is thus described;

"A gilt Communion Cup and Cover.
2 large Gilt Flagons.
2 large Basons and Covers."

* For extracts from his Memorandum Book, see *Trans. of the Leicest. Archæ. and Archæ. Soc.*, Vol. vi., p. 340.

In addition to the communion service here, there are also in the Duke's possession two very beautiful pieces of plate which may be said to be attached to the private chapel, inasmuch as they have been solely used in recent years at the christenings of different members of the family. These are :

A SILVER GILT EWER with agate sides. Height 16 in. Date 1579. (FIG. 9.)

Hall marks. 1. Small black letter B in a plain shield. 2. Leopard's head crowned. 3. Lion passant, each in a shaped outline. 4. Three trefoils slipt within a trefoil.

The main part of this ewer is formed with four solid rings of agate, one round the neck and three round the middle, held together with silver gilt mountings. The whole of the silver portion is beautifully ornamented chiefly in repoussé, with tritons in combat with dolphins round the upper part, fruit, birds and flowers, a turtle and lobster round the lower portion. From the short stem issue four projecting heads. Round the foot are masks and lion's claws. The handle of the ewer is formed with a triton wearing a shell for a helmet, his body terminating in two twisted tails; on his back is a large snail bearing a little one. Several little holes are to be seen in various parts of the ornamental work, to which were formerly attached small single roses. The ewer is so constructed that, when necessary, it can be taken into many different pieces.



Fig. 9. 1579. $\frac{1}{4}$ of full size. M. P. del.

A SILVER GILT DISH. Diam. $18\frac{5}{8}$ in. Depth $2\frac{5}{8}$ in. Date 1581. (FIG. 10.)

Hall marks. 1. Small black letter D in plain shield. 2. 3. and 4. as on ewer.

In the centre of this dish is a raised boss bearing an agate, round which are four oval ones, eight more oval agates being inserted in the edge. All the remaining part is beautifully ornamented in repoussé. From the boss are suspended a dolphin, turtle, lobster, and shrimp. Birds, masks, foliage, and arabesques cover all other spaces.

An ewer and basin such as these were "necessary enough, to say the least of it, in days when there was no such utensil as the modern fork. They were handed before and after every meal and after every course, the hands

being held over the basin whilst water, hot, cold, or scented, was poured over them from the ewer by the server."* In modern times the few pieces of plate similar to these which still exist are used either as ornaments to deck the sideboard, or else for the purpose of handing round rose water after dinner.



Fig. 10. 1581. $\frac{1}{4}$ of full size. M. P. del.

This ewer and dish have been set apart for some years for the sacred use mentioned above.

* O. E. P. p. 205. 2nd Ed.

Whether they were first used at the feasts of **Edward**, 3rd Earl of Rutland, cannot now be said. They are not named in the list of plate at Belvoir, made by **J. Frisby**, in 1752; but it does not of necessity follow that they were not then in the possession of the Duke, for they may have been at Haddon, or elsewhere.

BOTTESFORD.

SILVER CUP AND COVER. Weight of cup 14.5 oz. Height 7 in. Diam. of the bowl and foot $4\frac{1}{8}$ in. Height of stem $3\frac{1}{8}$ in. Date 1675.

Hall Marks. 1. Capital old English S in plain shield. 2. Leopard's head crowned. 3. Lion passant; each in shaped outline. 4. A. H. mullet above, in lobed stamp.

This cup, which is made of unusually thick metal, has a straight-sided bowl rounded off into an egg-shaped base, which rests on a straight thick stem with a round knob from whence the stem swells slightly into a plain foot.

SILVER COVER with a foot. Weight 3.6 oz. Diam. $4\frac{1}{4}$ in. Diam. of foot 2 in. Height of foot $\frac{3}{4}$ in. Date 1872.

London hall marks.

This is a plain slightly rounded cover with the edge turned up.

SILVER CUP AND COVER. Weight of cup 15.5 oz. Date 1872.

London hall marks.

This cup is of the same shape as the old one. On the bowl is the sacred monogram, below which is; "*This cup is the New Testament in my blood which is shed for you.*" Under the foot is, "*D. D. et Ecclesie S^{te} M^{ae} Bottesii quibusdam amicis Dei* 1872."

SILVER COVER. Weight 3.4 oz.

In all other respects like the first.

SILVER PATEN with a foot. Weight 11 oz. Diam. 9 in. Diam. of foot $3\frac{1}{4}$ in. Height of foot $1\frac{1}{2}$ in. Date 1675.

One mark only; the same maker's mark as that on the old cup.

This paten has a wide flat edge, the middle part being sunk in a shallow round. The foot is a disk attached to the paten by a stem swelling out at both ends.

SILVER PATEN with a foot. Weight 15 oz. Date 1872.

London hall marks.

This paten which is of the same shape as the old one, has the sacred monogram in its centre, and round its edge "*He is not here but is risen;*" "*Lo I am with you always.*" Underneath is the same inscription as that on the second cup.

SILVER FLAGON. Weight 38.6 oz. Height 13 in. Diam. at the top $4\frac{1}{2}$ in. At the foot $6\frac{1}{4}$ in. Date 1872.

London hall marks.

This is a straight-sided flagon narrowing towards the top. On the lid is a small globe surmounted by a cross; the four continents being engraved on the former. Upon one side of the drum is the sacred monogram, and "*Thy love is better than wine.*"

PEWTER FLAGON. Height $13\frac{1}{4}$ in. Diam. at the top 5 in. At foot $7\frac{1}{2}$ in. Marks. 1. X. 2. Small seeded rose and two other small marks. This is a straight-sided flagon narrowing towards the top.

PEWTER BASIN. Diam. $10\frac{3}{8}$ in. Depth 4 in. Marks. 1. X crowned. 2. An orb, a lion passant above, between L N.

In 1675 the lord of the manor and owner of a large portion of the parish of Bottesford was **John Manners**, 8th Earl of Rutland. In that year his only surviving son **John**, afterwards 1st Duke of Rutland, gave a bell to this church, which has been twice recast: * this gentleman may very possibly have given the ancient cup and paten at the same time.

The modern pieces of this service were the gift of the late rector of Bottesford, the Rev. Canon **Frederick John Norman**, M.A., and of some of the communicants resident in the parish. Canon **Norman** was the fifth son of **Richard Norman**, of Melton Mowbray, by Lady **Elizabeth Isabella Manners**, eldest daughter of **Charles**, 4th Duke of Rutland, and was born on 9th Nov., 1814. Having taken his B.A. Degree from Caius Coll., Camb., in 1838, he was in the same year ordained deacon by the Bishop of Winchester, and priest by the Bishop of Peterborough in 1839. Mr. **Norman**, after serving the curacy at Melton for some years, was instituted to the rectory of Bottesford in 1846. Here he effected during his long incumbency many improvements for the welfare of his parishioners; more than £4000 was raised for the repair of this grand church; large schools were built; clubs and various associations organized. In 1861 he was made rural dean of Framland I., and in 1872 an honorary canon of Peterborough. Canon **Norman**, who was a J.P. for co. Leicester, married on 22nd Feb., 1848, his first cousin, Lady **Adeliza Elizabeth Gertrude Manners**, youngest daughter of **John Henry**, 5th Duke of Rutland; by which lady, who died on 26th Oct., 1887, he had, with a daughter, three sons, the youngest of whom, **Robert Manners**, is now rector of this parish. The Rev. Canon **Norman** died on 30th Dec., 1888, and was buried beside his wife in Bottesford churchyard.

BRANSTONE.

SILVER CUP. Weight 10 oz. Height 7 in. Diam. of bowl $3\frac{5}{8}$ in.; of foot $3\frac{3}{4}$ in. Height of stem $3\frac{1}{4}$ in. Date 1625.

Hall marks. 1. Italic H in a plain shield. 2. Leopard's head crowned. 3. Lion passant; each in a shaped outline. 4. R.C., a pellet above, three nails below, in a plain shield.

This cup has a straight-sided concave bowl, resting on an evenly balanced stem, divided in half by a large round knob on a fillet, from whence it swells out to both ends. The foot is raised into a bold round. On the bowl is: "*Braunston Communion Cupp, Aprill the ixth 1626.*"

* *Church Bells of Leicestershire*, by T. North, F.S.A., p. 147. S. Clarke, Leicester.

SILVER PATEN with a foot. Weight 3 oz. Diam. $4\frac{1}{8}$ in. Diam. of foot $1\frac{3}{4}$ in. Height of foot $\frac{3}{4}$ in. Date 1625.

Hall marks as on cup.

This paten, which fits on to the cup with the foot downwards, has a flat edge, from whence the middle is sunk flat. The foot is a disk attached to the paten by the usual concave stem.

GLASS FLAGON with silver mountings. Height 9 in. Date 1872.

London hall marks.

This is a small jug-shaped flagon, with a silver neck, lid, handle and foot. On a silver band round the middle are four coloured stones. Under the foot is: "*Branstone Church, Leicestershire, 1873.*"

The flagon was presented in 1873, the year in which some improvements were carried out in the church, by the Rev. George Searl Ebsworth, who was then vicar of the neighbouring parish of Croxton Kerrial.

CROXTON KERRIAL.

(a)

SILVER CUP. Weight 13.5 oz. Height 9 in. Diam. of the bowl 4 in.; of the foot $5\frac{1}{4}$ in. Height of stem $6\frac{3}{8}$ in. Date 1876.

London hall marks.

This is an imitation mediæval cup with a V shaped bowl resting on a tall hexagonal stem and foot, ornamented with engraved work. On one division of the latter is the "Agnus Dei," and on another the sacred monogram. Underneath is "*Presented to Croxton Kerrial Church 22nd March 1877 by the Vicar.*"

(b)

SILVER PATEN. Weight 4.3 oz. Diam. $6\frac{5}{8}$ in. Date 1848.

London hall marks.

In the centre of this paten is the "Agnus Dei"; and round the edge "*Agnus dei qui tollis peccata mundi miserere nobis.*" Underneath is "*S. John Baptist's, Croxton Kerrial. In memory of Sarah Ashbourne, Widow. A.D. 1849.*"

(c)

SILVER FLAGON. Weight 13.1 oz. Height $8\frac{3}{4}$ in. Diam. at the top $1\frac{3}{4}$ in.; at the foot $3\frac{1}{4}$ in. Date 1879.

London hall marks.

This is a small jug-shaped flagon with an engraved band round the middle, and engraved foliage on its hexagonal foot. Underneath is "*Presented to Croxton Kerrial Church, by the Vicar, in memory of the marriage of his son the Rev. A. F. Ebsworth, 24th April, 1879.*"

(c)

GLASS FLAGON with silver mountings. Height $8\frac{3}{4}$ in. Diam. at the top $2\frac{3}{8}$ in. At the foot 3 in. Date 1855.

London hall marks.

This is a jug-shaped flagon with a silver top ornamented with some well engraved foliage and surmounted with a cross pattée.

In a terrier for this parish at Lincoln, dated 1822, the communion service here is said then to be: "One silver chalice weighing about 8 oz., one pewter tankard and two plates." Archdeacon **Bonney** also mentions a "plain silver cup." The cup here referred to proves to be a plated one, made in about the beginning of this century.

(a)

The modern silver cup and flagon were presented to this church by the Rev. **G. S. Ebsworth**, vicar of this parish from 1863 to 1882, in which year he resigned the living. He now resides at Holly Bank, Hollington Park, St. Leonard's-on-Sea. Mr. **Ebsworth's** son, the Rev. **Algernon Frederic Ebsworth**, vicar of East Retford, was married at Grove, co. Notts., on the date named on the flagon, to **Mary Frances**, daughter of the Rev. Canon **E. H. H. Vernon**, rector of Grove.

(b)

The silver paten was the gift of the then vicar of this parish, the Rev. **W. O. Norman**,* and a few friends, in memory of **Sarah Ashbourne**, who died on the 29th Dec., 1848, aged 77 years. Mrs. **Ashbourne** was the widow of Mr. **George Ashbourne**, who was born on the 3rd Oct., 1767, and died on the 28th March, 1831. Both were buried in this parish, their memory being recorded by a sarcophagus at the South East of the chancel, in which are sunk two slate panels bearing short inscriptions. Mr. **Ashbourne** represented a yeoman family, members of which for some years occupied land in this parish, and owned some in the parish of Chadwell.

(c)

The glass flagon was purchased with money from the offertory fund.

EATON.

SILVER PLATED CUP. Height 8 in.

SILVER PLATED PATEN. Diam. 10 in.

SILVER PLATED DISH with a foot. Diam. 10 in.

These three vessels all very plain in shape, are plated on copper.

In 1832 Archdeacon **Bonney** describes the communion service here as follows: "Small pewter flagon; ancient silver cup; small silver paten; pewter plate."

A few years after that date the old silver cup and paten were parted with and the present vessels bought.

* Now Rector of Harby.

HARSTON.

SILVER CUP. Weight 9 oz. Height $7\frac{1}{8}$ in. Diam. of the bowl $3\frac{1}{2}$ in.; of the foot $4\frac{1}{4}$ in. Height of stem $4\frac{3}{4}$ in. Date 1871.

London hall marks.

This cup has a V shaped bowl standing on a plain round stem and foot, the former being divided in half by a large round knob.

SILVER PATEN. Weight 3 oz. Diam. $5\frac{1}{2}$ in. Date. 1869.

London hall marks.

This is a plain paten with an ornamental cross in the centre.

SILVER FLAGON. Weight 13 oz. Height $10\frac{1}{2}$ in. Diam. of the top $1\frac{3}{4}$ in.; of the foot $3\frac{1}{2}$ in. Date 1871.

London hall marks.

This is a plain jug-shaped flagon with a cross bottonnée on the lid. Each of these three pieces, has under the foot, this inscription: " + Harston Church 1871."

SILVER PLATED PEWTER PLATE. Diam. 8 in.

No marks.

This plate, formerly a salver, with three feet now gone, has a gadrooned edge.

PEWTER FLAGON. Height $11\frac{1}{2}$ in. Diam. at the top $3\frac{3}{4}$ in.; at the foot $5\frac{1}{2}$ in.

Marks: 1. X crowned. 2. Lion passant in a small shaped outline, repeated thrice. 3. H.I. in a shaped oblong. This is a straight-sided flagon with an R shaped handle and a raised lid surmounted with a knob.

In 1832 there was here "a plain silver cup and an old silver paten with rim broken."

The paten has not been heard of in recent years. The cup was parted with when the modern service was purchased. This was done at the cost of the Rev. W. H. E. Welby the rector of the parish, assisted by other members of his family.

KNIPTON.

(a)

SILVER CUP. Weight 18 oz. Height $8\frac{3}{8}$ in. Diam. of the bowl $4\frac{1}{2}$ in.; of the foot $4\frac{1}{4}$ in. Height of stem $3\frac{3}{4}$ in. Date 1685.

Hall marks. 1. Small black letter H in a plain shield. 2. Leopard's head crowned in a circle. 3. Lion passant in plain oblong. 4. R. C., three pellets above and below, in a dotted circle. This cup has a deep straight-sided bowl with a lip slightly bell-shaped, and a flat base. Its thick stem is divided in half by a gadrooned knob between small mouldings, from whence it swells to the bowl and into a plain foot with an ovolo round its edge and the lion

passant underneath. Upon the bowl are these arms within a lozenge with foliage on either side; *Sable a chevron between three escallops Argent; Michell; impaling a chevron Ermine between three herons. Heron?* (FIG. 11.) Underneath is "*Jane Michell.*"

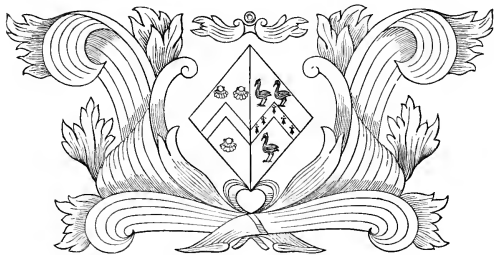

Fig. 11.

SILVER PATEN with a foot. Weight 7.5 oz. Diam. $6\frac{1}{4}$ in. Diam. of foot $2\frac{7}{8}$ in. Height $\frac{7}{8}$ in. Date 1685.

Hall marks as on cup.

This paten, which fits on to the cup with the foot downwards, has a flat edge, from whence the middle part is slightly sunk. The foot is a disk attached to the paten by a thick concave stem. On the foot is the sacred monogram, a cross crosslet above, a heart and three nails below, within a circle of glory.

(b)

GLASS FLAGON with silver mountings. Height $10\frac{3}{4}$ in. Date 1869.

London hall marks.

This is a jug-shaped flagon with a silver neck, lid, and handle. On a silver band round the middle is "*The gift of the Rev. G. Searle Ebsworth, Vicar of Croxton Kerrial 1869.*"

PEWTER FLAGON. Height 13 in. Diam. at the top $4\frac{3}{8}$ in. At the foot $7\frac{1}{8}$ in.

Marks. Inside on the bottom, "I N," a fleur-de-lis below, in a shaped shield.

This is a tall straight-sided flagon with an R shaped handle, and a lid raised into a knob.

PEWTER PLATE. Diam. $8\frac{1}{2}$ in.

Marks. 1. On edge, "K," for Knipton. 2. In four plain shields crowned: (a) Lion rampant. (b) Royal crown. (c) Anchor. (d) T. K. 3. Underneath: an anchor crowned between "1675," "Thomas King" above, "London" below.

PEWTER PLATE. Diam. $9\frac{1}{2}$ in.

Marks. 1. X crowned. 2. Out of a ducal crown an eagle rising towards sun in splendour, in an ornamental shape; repeated twice. 3. "V and W." 4. "Birmingham."

(a)

The origin of the silver cup and paten is told in the following clause of **Jane Michell's** will, made 6th Oct., 1686, and proved the same year at Leicester; "*I give unto the church of Knipton aforesaid the sum of £5 towards the exchange of the communion plate.*"

This lady married, as his second wife, **Thomas Michell**, Esq., lord of the manor and principal landowner of South Witham, co. Lincoln,

the representative of a family owning land for many years in Coston, co. Leicester, being the son of **Thomas Michell**, Esq., lord of the manor of that place, by **Isabella** his wife.

Thomas Michell, by his first wife **Katherine**, daughter of **John** and **Margaret Blyth**, whom he married on 30th May, 1618, at Tickencote, Rutland, had, with three sons and a daughter who died young, two daughters, who became his co-heirs. The eldest, **Ann**, was married first to **Luke Norton**, who died in 1666, and secondly to **Henry Stone**, of Skellingthorpe, co. Lincoln; she died on 2nd Dec., 1673, aged 50, leaving no surviving issue by either husband. The other daughter, **Elizabeth**, married **Charles Halford**, Esq., of Edith Weston, co. Rutland, who inherited through his wife the **Michell** property at Coston and South Witham. **Elizabeth Halford** died on 17th Feb., 1694, aged 63, and was buried in the chancel of South Witham church, on the East wall of which is a small alabaster monument to her memory, bearing a Latin inscription, and surmounted with these arms: *Argent a greyhound passant Sable on a chief Azure three fleur-de-lis Or*; **Halford**; impaling per chevron *Gules and Sable a chevron between three swans Argent*; **Michell**. Crest: *A greyhound's head coupé at the neck Sable collared Or*.^{*} Her elder sister, **Ann Stone**, was buried in the North transept of South Witham church, on the East wall of which is a large oblong stone monument to her memory, with an arabesque border and English inscription; above is this crest: *Out of a ducal coronet Or a griffin's head Ermine between two wings Or*; and "Tantum mors corporum edax;" at the foot of the monument are these arms: *Argent three cinquefoils Sable a chief Azure*; **Stone**; impaling **Michell** as before.†

The father of these two ladies, **Thomas Michell**, died in about 1660, and was buried with their mother **Katherine** in South Witham church. His second wife, **Jane**, the donor of this cup and paten, when left a widow, retired to Knipton, where she lived for the rest of her life. She died without issue, and was buried, on 21st Oct., 1686, in the aisle next the chancel of Knipton church; in the entry in the parish register recording her burial she is described as "a person of great worth and goodness."

In addition to this bequest of communion plate Mrs. **Jane Michell** left £10 to the poor of Knipton, the interest to be distributed every Good Friday by the rector and wardens, "regard being had to such poor widows as shall be then living in the said parish." To her step-daughter **Elizabeth Halford**, she left her embroidered bible and a 20s. piece of gold to buy a ring; to **Cyprian Banbury**, rector of the parish, and his wife **Mary**, £5 each. Her nephews **Richard** and **John**, sons of her brother-in-law **John Tunstal**, she appointed executors and residuary legatees.

(b)

The inscription on the glass flagon speaks for itself.

MUSTON.

(a)

SILVER CUP. Weight 11.5 oz. Height 6½ in. Diam. of bowl 4 in.; of foot 3½ in. Date 1813.

* Head is broken off. † The bearings are simply cut in relief, and not tinctured; the arms on the former monument are tinctured only. It will be noticed that these arms are quite different to the arms of **Michell** on the silver cup.

London hall marks.

This cup, formerly a secular one, has a wide, deep and straight-sided bowl, reeded round the lower part; a short stem and plain round foot, round the top of which runs an egg and tongue ornament. On the bowl is: "*Muston Church, Aug. 12, 1863.*"

SILVER PATEN with a foot. Weight 9.4 oz. Diam. $7\frac{1}{2}$ in. Diam. of foot $3\frac{1}{2}$ in. Height of foot $1\frac{3}{4}$ in. Date 1863.

London hall marks.

This is a plain flat paten, having in its centre the same inscription as that on the cup.

(b)

SILVER BOX. Weight 4.5 oz. Diam. $3\frac{3}{8}$ in. Height $1\frac{7}{8}$ in. Date 1842. Birmingham hall marks.

This is a round box, formerly for secular use, with a flat lid ornamented with engraved foliage. In the centre of the lid is: "*Guide me with Thy Counsel and afterward receive me to Glory.*"

In 1832 the communion service here consisted of the following pieces: "An old silver cup with a wooden bottom, an old silver paten with rim broken, a pewter flagon, plate and basin."

(a)

The silver cup and paten now here were presented by the Rev. **George Gordon**, rector of the parish. He was the son of **George Gordon**, a doctor in Lincoln, and was born in 1792; matriculating at Brasenose, Oxford, on 1st May, 1811, he took his B.A. from thence in 1814, and M.A. in 1818.* Having taken orders Mr. **Gordon** was presented to the rectory of Whittington, co. Derby, in 1816, and to this living in 1822; both benefices being held by him till his death, on 15th June, 1872. He was buried in Muston churchyard.

(b)

The silver box has been presented by the Rev. **J. Furnival**, the rector of this parish.

PLUNGAR.

SILVER CUP. Weight 9.1 oz. Height $7\frac{1}{2}$ in. Diam. of the bowl $3\frac{5}{8}$ in.; of the foot $3\frac{1}{2}$ in. Height of stem $4\frac{1}{2}$ in. Date 1848.

London hall marks.

This cup has a V-shaped bowl with a flat base, supported by a tall stem bulging out into a round knob. Round the lip is: "*The cup of blessing which we bless, is it not the communion of the blood of Christ, 1 Cor. x. 16;*" below which is the sacred monogram. Round the top of the foot is: "*He that drinketh my blood, dwelleth in Me, and I in him, John vi. 56.*" Under the foot is: "*Plungar, 1848.*"

SILVER PATEN with a foot. Weight 6.9 oz. Diam. $6\frac{1}{4}$ in. Diam. of foot $3\frac{1}{8}$ in. Height of foot $1\frac{5}{8}$ in. Date 1848.

London hall marks.

* *Alumni Oxonienses.* J. Foster.

This is quite a plain paten with the sacred monogram in its centre, and round its edge "*The bread which we break is it not the communion of the body of Christ. 1 Cor. x. 16.*" Under the foot is "*Plungar, 1848.*"

PEWTER DISH with a foot. Diam. 9 in. Diam. of foot 5 in. Height of foot 2½ in.

This is a large plain dish of modern make with "*Plungar Church, 1835,*" in its centre.

According to Archdeacon **Bonney** the communion service here, in 1832, consisted only of a silver cup and pewter plate. The former was no doubt parted with when the present cup and paten were given by the late Rev. **F. G. Burnaby, M.A.,** Vicar of Barkestone and Plungar.*

 REDMILE.

(a)

SILVER CUP. Weight 13.9 oz. Height 8¾ in. Diam. of bowl 3½ in.; of foot 4 in. Height of stem 4¾ in. Date 1840.

Sheffield hall marks.

This cup has a straight-sided bowl standing on a plain stem and foot. On the bowl is the sacred monogram with a cross in a circle of glory. Under the foot is "1841."

(b)

SILVER PATEN. Weight 3.9 oz. Diam. 5¼ in. Date 1882.

London hall marks.

This is a plain flat paten with a cross patonce in a circle on its edge.

GLASS FLAGON with silver plated mountings. Height 11¼ in.

The communion service here in 1832, is said by Archdeacon **Bonney** to have been a plain silver cup, large pewter flagon, and two pewter plates.

(a)

It is thought that the silver cup now here was exchanged for the older one in 1841, at the cost of the then rector of the parish, the Rev. **Thomas Powys Outram**. He was the eldest son of the Ven. **Edmund Outram, D.D.,** Archdeacon of Derby, by **Beatrix**, eldest daughter of **Richard Postlethwaite**, of Lancaster, and was born on 27th April, 1802. He took his B.A. degree from St. John's Coll., Cambridge, in 1825 and M.A. in 1830, and died rector of Redmile, on 17th May, 1853. Mr. **Outram** married on 31st July, 1827, **Ann**, daughter of **Samuel Hodgkinson**, of Kilton, Worksop; which lady died on 27th May, 1857.†

(b)

The silver paten is the gift of the second son of the Rev. **T. P. Outram**, and present rector of the parish, the Rev. **George Sanford Outram**.

* *Ibid* Barkestone, p. 111, and St. Saviour's, Leicester, p. 107. † *Burke's Peerage and Baronetage*.

SPROXTON.

SILVER CUP. Weight 7.7 oz. Height $6\frac{3}{8}$ in. Diam. of bowl $3\frac{3}{8}$ in. ; of foot $2\frac{7}{8}$ in. Height of stem $2\frac{3}{8}$ in. Date *circa* 1570. (PLATE 10.)

One mark only; leopard's face in a shaped shield.

This cup is a little different to those at Saltby and Stonesby, inasmuch as it has a deeper bowl, nearly straight-sided in its lower part, from whence it gradually swells out into a bell-shaped lip. Its short stem has also the addition of a small knob formed by a round moulding on a fillet. In other respects this cup is the same in character as the other two. It is made of rather thicker metal than the others, which accounts for its heavier weight.

SILVER PLATED PATEN. Diam. 6 in.

This modern paten has an ornamental cross in its centre:

 SALTBY.

SILVER CUP. Weight 6 oz. Height 6 in. Diam. of bowl $3\frac{3}{8}$ in. ; of foot $2\frac{7}{8}$ in. Height of stem $2\frac{3}{8}$ in. Date *circa* 1570. (PLATE 10.)

No marks now visible.

This cup is almost exactly like the one at Stonesby and was probably made by the same maker; his mark, the leopard's face, having perhaps become worn off this one. It has a bowl shaped into an inverted truncated cone, with a bell-shaped lip, standing on a plain straight stem which swells out at both ends into vertical edges round which run lines. The foot is of the usual shape with the egg and tongue ornament round its edge.

SILVER PLATED PATEN. Diam. 6 in.

In the centre of this modern piece is the sacred monogram.

PEWTER PLATE. Diam. $9\frac{1}{2}$ in.

Marks. 1. On the edge, in four small shaped stamps, (a) Anchor. (b) Lion passant. (c) Crown. (d) T.K. 2. On the back, an anchor crowned between the date 1675; if legible, "*Tho. King*" would be seen above, and "*London*" below.

PEWTER PLATE. Diam. $7\frac{1}{4}$ in.

Marks. 1. Fleur-de-lis. 2. S.H. in a circle. 3. London. 4. X crowned.

In the terrier for 1709 at Lincoln, the communion service here is thus named; "one flagon and two plates of pewter. One silver cup containing near one pint."

 STATHERN.

(a)

SILVER CUP. Weight 12.3 oz. Height $8\frac{1}{8}$ in. Diam. of the bowl $4\frac{1}{4}$ in. ; of the foot $4\frac{1}{8}$ in. Height of stem 3 in. Date 1696.

Hall marks. 1. Small black letter T in a plain shield. 2. Leopard's head crowned in a circle. 3. Lion passant in plain oblong. 4. I R, a fleur-de-lis above and below, in a shaped stamp.

This cup has a straight-sided bowl with a slightly projecting lip and a flat base. Its stem is straight as far as a plain round knob from whence it swells out into a foot with an ovolo moulding round its edge, and the lion passant underneath. On the bowl are these arms; on a pile three crescents, a crescent for a difference, **Cooke**. (FIG. 12.) Round the lower part of the bowl is; "*Ex dono Richardi Cooke S T P Rectoris de Statherin in Comitatu Leicestria 1696.*"*

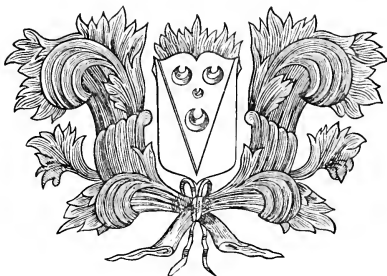

Fig. 12.

SILVER PATEN with a foot. Weight 10 oz. Diam. $7\frac{1}{2}$ in. Diam. of foot $3\frac{3}{8}$ in. Height 2 in. Date 1696.

Hall marks as on cup.

This dish has a flat edge round which is the latter part of the same inscription. The foot is a disk attached to the stem by a tall concave stem.

(b)

SILVER PATEN. Weight 5.8 oz. Diam. 7 in. Date 1849.

London hall marks.

This is a plain paten having in its centre the sacred monogram with a cross and three nails within a circle of glory.

SILVER FLAGON. Weight 18.5 oz. Height $10\frac{1}{2}$ in. Diam. at the top $2\frac{7}{8}$ in.; at the foot $4\frac{1}{2}$ in. Date 1849.

London hall marks.

This is a plain straight-sided flagon with a spout.

(a)

Dr. **Cooke**, the donor of the silver cup and oldest paten, was one of the younger sons of **Richard Cooke**, yeoman, of Whepstead, co. Suffolk, by **Martha**, his wife, and was baptized in that parish on 16th Feb., 1641.† He was admitted to St. Peter's College, Cambridge, and from thence took his B.A. degree in 1661; he was elected a fellow on 7th Nov., 1663, and graduated M.A. two years after. Having taken orders, Mr. **Cooke** was appointed by his college in 1666 to the vicarage of Cherry Hinton, which he served from college, as did many of his predecessors and successors. He was proctor to the University in 1689; soon after which he resigned his fellowship

* *Sic.*

† Parish Register.

and vicarage, in order to take the rectory of Stathern to which he was inducted on 24th Nov., 1690: in 1692 he proceeded to the degree of D.D. At Stathern Dr. **Cooke** lived and worked for the rest of his life, dying unmarried on 23rd Oct., 1704.

He was buried on the 31st in the chancel of the church, on the North wall of which is a marble monument to his memory, surmounted by his arms as on the cup, and bearing a latin inscription,* in which he is spoken of as being "*Amicus charus, omnibus gratus, nemini odiosus, fide orthodoxus, pietate insignis.*"

By his will, dated 12th Dec., 1702 and proved P.C.C. 2nd Dec., 1704, Dr. **Cooke** bequeathed, in case he did not make the gift in his life-time, "so much money as shall purchase a yearly rent charge of 52s., or land of that value," the interest to be spent by the rector and churchwardens in purchasing 12 penny loaves to be given every Sunday to as many poor men or women, the parish clerk being one, who shall attend the whole morning service in Stathern church; the gift being forbidden to be made "to any children, though their parents be then sick." To his native parish of Whepstead, Mr. **Cooke** left £5 to buy a cup for the communion; making a similar bequest to Cherry Hinton.† Legacies of various amounts were left to his brothers, **John Cooke**, of Whepstead, and **James Cooke**, woollen draper, of London; to his nieces, **Ann**, **Frances**, and **Jane Cooke**, and **Margaret Booty**; to his nephews, **James** and **Robert Cooke**: he appointed as his sole executor and residuary legatee, his nephew, **John Cooke**, mercer, of Bury St. Edmund's.

(b)

The rector of this parish in 1849, and the probable donor of the two modern pieces of plate, was the Rev. **George Ray**, M.A., now of Brentwood, Essex. In 1867 he resigned Stathern, and accepted the curacy of All Saints', Leicester, of which parish he was made vicar in 1874, resigning that cure in 1881.

* For which see *Nichols*, Vol. ii., p. 359. † The cup now at Whepstead is undated: for Cherry Hinton, a paten and not a cup was bought: this is inscribed, "*Ev dono Richardi Cooke, D.D., hujus, Ecclesie Vicarii.*"



"'Sir,' said he, 'I am of Arthur's court, and my name is Sir Launcelot du Lake, that am in the quest of the Sancral.'"

FRAMLAND SECOND DEANERY.

BUCKMINSTER CUM SEWSTERN.	GARTHORPE. GOADBY MARWOOD.	BRENTINGBY. WALTHAM-ON-THE- WOLDS.
CALDWELL.	SAXBY.	WYFORDBY.
COSTON.	STAPLEFORD.	WYMONDHAM.
EASTWELL.	STONESBY.	
EDMONDTHORPE.	THORPE ARNOLD.	

BUCKMINSTER CUM SEWSTERN.

SILVER CUP AND COVER PATEN. Weight of cup 8.8 oz. Height $7\frac{1}{4}$ in. Diam. of bowl $3\frac{3}{4}$ in.; of foot $3\frac{1}{4}$ in. Height of stem $3\frac{1}{2}$ in. Date 1771.

Hall marks. 1. Capital old English Q in plain shield. 2. Leopard's head crowned in rounded shield. 3. Lion passant in plain oblong. 4. T. W., pellet between, in plain oblong. Mark of *Thomas Wallis*.

This cup has an egg-shaped bowl swelling out into a bell-shaped lip, standing on a straight narrow stem and plain foot, the former having a small moulding for a knob.

SILVER COVER PATEN with a foot. Weight 4.3 oz. Diam. $4\frac{1}{2}$ in. Diam. of foot $1\frac{3}{4}$ in. Height of foot 1 in. Date 1771.

Hall marks as on cup.

This cover paten has a flat raised edge ornamented with a narrow moulding. Its foot is a disk, attached to the paten by a thick stem swelling out a little at each end.

SILVER PATEN. Weight 5 oz. Diam. 6 in. Date 1884.

London hall marks.

This is a plain paten with a wide flat edge, on which is a cross *bottonnée*.

SILVER PLATED FLAGON. Height 10 in.

This is a jug-shaped flagon, with this inscription on its side: "*Given by Mrs. J. L. Blagdon to the parish of Buckminster cum Sewstern, Advent, 1872.*"

In a terrier made in 1708, and quoted by *Nichols*, Vol. ii., p. 126, it is recorded that this parish then had; "a chalice, which, with the cover, weighed nine ounces and a half. No inscription on it."

The terrier for 1745 at Lincoln, mentions "A pewter flagon. A silver cup weighing about $9\frac{1}{2}$ oz." Here we have an instance of a cover not being actually named though included in the weight.

Archdeacon **Bonney** in 1832, mentions the communion service thus: "No flagon, no basin, a small silver paten; there is a silver cup very old without an inscription, not exhibited, the key of the box not being kept here." Remembering how erroneously such things are often spoken of, it is just

possible that the "very old" cup described, but not shown to the Archdeacon, was simply the one now in use, which may have taken the place of the ancient covered cup, of possibly Elizabethan make.

The modern silver paten was presented by the Earl of **Dysart**, who has restored Buckminster church in an admirable manner.

The donor of the silver plated flagon was a sister of the Rev. F. D. **Rabbits**, vicar of this parish from 1872 to 1882.

This communion service is also used in the modern chapel of ease at Sewstern.

CALDWELL.

SILVER CUP. Weight 9.3 oz. Height $7\frac{1}{2}$ in. Diam. of bowl $3\frac{3}{4}$ in.; of foot $3\frac{5}{8}$ in. Height of stem $3\frac{5}{8}$ in. Date *circa* 1570.

No hall marks.

This cup has a bowl shaped into an inverted truncated cone, with sides bulging slightly out; this part of the cup, which is plainly ancient, stands upon a modern stem and foot, designed more or less after the usual Elizabethan pattern, the knob being formed with small mouldings. This modern stem replaced, perhaps, the ancient one in about 1849.

SILVER PATEN. Weight 4.5 oz. Diam. $6\frac{5}{8}$ in. Date 1848.

London hall marks.

This is an imitation mediæval paten, with the sacred monogram within a star in the centre. Round its edge is: "*Per crucem et passionem tuam libera nos Domine.*"

On the cover of one of the registers of Caldwell is written this memorandum:

"A cup and paten were delivered to the churchwarden of this parish (Mr. **Wood**), to be kept by him and his successors for ever, for the celebration of the sacrament of the Lord's Supper in this parish; as witness our hands this 29th day of July, 1849.

John Healy, Curate.

William Wood, Churchwarden.

James Marshall.

Thomas Morris.

Catherine Stow."

From an entry in the registers of Waltham we learn that this cup belonged formerly to that parish, and was sold to Caldwell.

The communion service formerly in use here is said to have been of pewter; no mention is made of it by Archdeacon **Bonney**, since this parish is in the peculiar of Rothley, and was not under his jurisdiction.

COSTON.

SILVER CUP. Weight 14.7 oz. Height 8 in. Diam. of bowl $4\frac{1}{8}$ in.; of the foot 5 in. Height of the stem $5\frac{1}{2}$ in. Date 1848.

London hall marks.

This cup has a globular-shaped bowl, and hexagonal stem, knob, and foot. Upon the knob are six diamond-shaped bosses with a four-leaved flower on each, and between each boss is open tracery above and below. The foot is shaped in six lobes on one of which is the sacred monogram.

SILVER PATEN. Weight 4.5 oz. Diam. $6\frac{3}{8}$ in. Date 1848.

This paten has a flat edge, the middle part being sunk in a six-lobed depression: the sacred monogram is in the centre. Round the edge is "*Per crucem et passionem tuam libera nos domine.*"

PEWTER PLATE. Diam. $9\frac{3}{4}$ in.

Marks. 1. On the edge, "T. W. 1694." 2. Four small stamps, quite illegible. 3. Underneath; anchor crowned between the date 1675, round the anchor is a band with "*The King,*" not legible, above, and "London" below. 4. "1694." In the first mark "C." probably stands for Coston and "T. W." for the initials of the purchaser; "1694" being the date of the purchase.

Up to the time that the new cup and paten were purchased, there belonged to this parish what Archdeacon **Bonney** calls a "very ancient silver cup and cover with this inscription, '*The communion cup of Coston.*'" When the new pieces were bought in 1848, the old cup with its cover was sold to the silversmith for £5, which sum helped to pay for the modern cup and paten. The rest of the money for the purchase of the new plate was given by the late rector of the parish, the Rev. the Hon. **John Sandilands**. This gentleman was the second son of **James**, 10th Baron **Torphichen**, by his wife, **Margaret Douglas**, second daughter of **John Sterling**, Esq., of Kippendavie, and was born on 1st Nov., 1813. He took his degree of M.A. from Trinity College, Cambridge, in 1835, and was ordained deacon and priest in 1838: he was appointed to the rectory of Coston in 1841, which he held till his death on 18th March, 1865. Mr. **Sandilands** married on 24th July, 1845, **Helen**, daughter of **James Hope**, Esq., clerk to the signet, by which lady, who died in 1887, he had four sons and a daughter, the eldest son being the present Lord **Torphichen**. A reredos of carved oak has been placed in Coston church to the memory of Mr. and Mrs. **Sandilands**, by their children.

EASTWELL.

(a)

SILVER CUP AND COVER PATEN. Weight of cup 9.1 oz. Height $6\frac{3}{4}$ in. Diam. of bowl 4 in.; of foot $3\frac{5}{8}$ in. Height of stem $2\frac{3}{8}$ in. Date 1680.

Hall marks. 1. Small black letter C in plain shield. 2. Leopard's head crowned in oval shield. 3. Lion passant in plain oblong. 4. I. S., pellet between, a rose below, in a shaped shield.

This cup has a plain straight-sided bowl with a lip slightly bell-shaped and a flat base. Its stem is divided above the middle by a large, plain, round knob, from whence it swells to the bowl and into a plain flat foot rounded off into a flat edge. On the bowl is this inscription; "*Ex dono Christophori Wright Rectoris Eastwell Leicest: 1681.*"

SILVER COVER PATEN with foot. Weight 3.1 oz. Diam. $4\frac{1}{2}$ in. Diam. of foot $1\frac{7}{8}$ in. Height of foot $\frac{3}{4}$ in. Date 1680.

Marks. Leopard's head crowned and maker's mark as on cup.

This is a flat paten with a vertical edge maker turned outwards. Its foot is a disk attached to the paten by a straight narrow stem.

(b)

SILVER DISH. Weight 7.9 oz. Diam. 7 in. Depth 1 in. Date 1721.

Hall marks. 1. Capital Roman F in a plain shield. 2. Britannia. 3. Lion's head erased. 4. Tu., a pellet below, in a plain pointed shield. Mark of *Edward Turner*.

This dish, which was formerly a secular piece of plate, in the possession, perhaps, of the donor's family, is made out of one thick piece of metal, being a round flat dish with deep turned-up sides divided into nineteen lobes with indented edges. Round the bottom is "*Ex dono Johannis Knipe Rectoris Eastwel Leicest: 1781.*"

In a terrier for this parish made in 1708, recorded by *Nichols*, (Vol. ii. p. 169,) a pewter tankard is mentioned as then belonging to the church as well as the silver cup and cover. From Archdeacon **Bonney's** inventory we learn that this flagon and a pewter plate were stolen out of the chest in about 1828.

(a)

With respect to **Christopher Wright**, the donor of the cup and paten, the first fact that can be for certain recorded is that he was chosen on 20th Oct., 1653, to be minister of St. Martin's Leicester, the parish engaging to provide him with £80 a year and the vicarage house.* He remained at that post until he obtained the rectory of Eastwell, into which he was inducted in Jan., 1655-6.† During the Commonwealth he threw in his lot with the presbyterian party, and was one of those "well affected ministers of the gospel in the county of Leicester," who signed the "humble representation" to the rump parliament in 1659.‡ At the restoration, however, he submitted to the re-establishment of church order and was formally instituted into this rectory by the Bishop of Lincoln on 30th Nov., 1660.§ He was permitted thirteen years later to resign the living in favour of his eldest son, **John**, who was instituted on 11th July, 1673,|| and died on 26th Feb., 1674-5, after which the father was again presented to this rectory, being inducted on 25th March, in that year:† and here **Christopher Wright** remained till his death on 4th Jan., 1685-6,† at the age of 75; he lies buried in front of the altar, beneath a slab inscribed by himself.

* *Nichols*, Vol. i., p. 580.

+ Parish Register.

‡ *Nichols*, Vol. ii., p. 170.

§ Bp. Sanderson's Register.

|| Bp. Fuller's Register.

He was twice married, and had by his first wife, **Margaret**, buried here on 18th June, 1661,* aged 44, a son, **John**, born at Bulwick, co. Northants., on 5th and baptized on 14th May, 1646;* a son, **Christopher**, born at Loddington in 1648, and admitted, with his elder brother, to St. John's College, Cambridge, on 28th June, 1664;† a son, **William**, linen draper of London, who died on 14th Oct., 1680; and a daughter, **Mary**, who died on 13th Oct., 1680. By his second wife, **Elizabeth**, who was buried here on 4th April, 1679,* he had a son, **Joseph**, baptized here on 24th April, 1663.*

(b)

The donor of the silver dish, just one hundred years later, I take to have been **John Knipe**, the son of Mr. **Edward** and **Susannah Knipe**, who was baptized at Grantham on 14th May, 1722.‡ He was admitted to Clare College, Cambridge, on 11th June, 1739,§ and took his B.A. from thence in 1742. The Rev. **John Knipe** was instituted to the rectory of Eastwell on 25th Nov., 1757,|| but his name does not appear in the parish register so that he probably held another benefice. He seems to have resided in his native town: at any rate he was buried there on 27th May, 1798;‡ at the east end of Grantham church is a marble monument to his memory bearing a short inscription.

EDMONDTHORPE.

SILVER CUP AND COVER PATEN. Weight of cup 7.1 oz. Height 6½ in. Diam. of bowl 3¾ in.; of foot 3 in. Height of stem 2¼ in. Date *circa* 1570. (PLATE 10.)

No hall marks.

This cup, made perhaps by the maker who used the leopard's face as his mark, has a deep bowl, straight-sided below, swelling out higher up into a bell-shaped lip. Its stem is a short, evenly balanced one, divided in half by a round moulding on a fillet, from whence it swells out at each end into vertical edges, round which run horizontal lines. The foot is rounded off into the usual vertical and flat edges, the egg and tongue ornament being on the latter.

SILVER COVER PATEN with a foot. Weight 3.2 oz. Diam. 4¾ in. Diam. of foot 2½ in. Height of foot 1½ in. Date *circa* 1570. (PLATE 10.)

No hall marks.

This paten is sunk deeply from a flat edge, round which is a thick rim. The foot is a thin disk, attached to the paten by a tall conical-shaped stem.

(a)

SILVER CUP. Weight 10.5 oz. Height 7¾ in. Diam. of the bowl and foot 4 in. Height of stem 3¾ in. Date 1699.

Hall marks. 1. Court hand D. 2. Lion's head erased. 3. Britannia. 4. F. A., three pellets above and one between and below, in a circle.

This cup has a straight-sided bowl, standing on a thick stem divided in half by a small moulding for a knob, from whence it swells out to both ends. The foot has an ovolo moulding round its edge. On the bowl is the sacred monogram, with a cross and three nails, within a circle of glory, and this inscription: "*The gift of Bridget Lady Smith anno 1699.*"

* Parish Register.

† *Admissions to St. John's Coll., Camb.* J. E. B. Mayor, p. 165

‡ Parish Register

§ Admission Book. || Bp. Thomas' Register.

SILVER PATEN with a foot. Weight 4.9 oz. Diam. $4\frac{7}{8}$ in. Diam. of foot $2\frac{1}{2}$ in. Height of foot $\frac{3}{4}$ in.

This paten, which is stamped only with the maker's mark as on the last cup, has a flat edge ornamented with a few lines, from which the main part is sunk flat. The foot is a disk, attached to the paten by a stem swelling out at both ends. On the foot is the sacred monogram, etc., and underneath the paten the same inscription as that on the last cup.

(b)

SILVER DISH with a foot. Weight 12.8 oz. Diam. $8\frac{1}{4}$ in. Diam. of the foot $3\frac{1}{2}$ in. Height of foot $2\frac{1}{4}$ in. Date *circa* 1710.

Hall marks. 1. Britannia. 2. Lion's head erased; both faint, the other two being quite worn off.

This is a flat dish with a raised flat edge, round which is this inscription: "*The legacy of Dame Olivia Smith, to the church of Edmondthorpe in the county of Leicester, 1710.*" This dish stands on a hollow drum, which swells out into a plain foot rounded off at the edge.

(c)

SILVER FLAGON. Weight 41.2 oz. Height $11\frac{3}{8}$ in. Diam. at top $3\frac{3}{4}$ in.; at foot $4\frac{1}{2}$ in. Date 1728. (PLATE 9.)

Hall marks. 1. Capital Roman N in a plain shield. 2. Leopard's head crowned, in a plain shield. 3. Lion passant, in a plain oblong. 4. R. B., in a plain oblong, with corners clipt. Mark of *Richard Bayly*.

This is a jug-shaped flagon, of solid construction and graceful shape. It was originally a secular piece of plate. Upon one side is this coat of arms: *Quarterly, 1 and 4, Gules, on a chevron Or between three bezants as many crosses pattée fitchée Sable, Smith; 2 and 3, Azure, a fesse Argent between three hedgeshogs passant Or, Heriz. Crest: Out of a ducal coronet an heraldic antelope's head coupéd Argent attired Or crined Sable.* Round the shield is some good engraving. In front is: "*The gift of Mrs. Smith, widow of Edward Smith, Esq., to Edmondthorpe church, in 1769.*"

SILVER FLAGON. Weight 40.8 oz.

Exactly like the last.

From Archdeacon **Bickham's** inventory of 1778, we learn that the church plate here was the same then as now.

(a)

The second cup and paten were bought in accordance with this clause in **Bridget, Lady Smith's** will, made 10th Nov., 1669, and proved 8th Dec., following P.C.C.: "*I also give to the church of Edmondthorpe in Leicestershire, one silver chalice with my name engraved thereon to the value of five guineas.*" This lady was the daughter of **Bartholomew Waite**, Esq., of Andover, Hants., and was born in 1624. She was twice married: first in 1653 to **Richard Bayly**, Esq., of Gray's Inn, son and heir of **Lionell Bayly**, Esq., of Woodford, Essex, who died without issue on 25th May, 1694, aged 64.

He was buried in Woodford church, on the South wall of which is an oval monument of marble to his memory, surmounted by his arms: *Argent on a fesse engrailed between three martlets Gules as many bezants.* Crest: *A mural crown*: below is an inscription in English and Latin, and the arms of **Bayly**, *impaling*; *Argent a chevron between three bugle horns Sable garnished Or, Waite.*

Bridget, Richard Bayly's widow, afterwards became the third wife of **Sir Edward Smith**, alias **Heriz** 1st Bart., of Edmondthorpe, the grandson and representative of **Sir Roger Smith**, Knt., the purchaser of this lordship in 1620.* **Sir Edward Smith**, Bart., who outlived his third wife died on 6th Sep. 1707, aged 78. Against the South wall of the South aisle of Edmondthorpe church, is a large monument on steps bearing an inscription to the memory of himself and his first two wives and the arms of both; his third wife, the donor of this cup, is mentioned shortly in the inscription allotted to **Sir Edward**; she died without issue, and was buried in the vault in this church, on 3rd Jan. 1699.

The memory of **Bridget, Lady Smith**, was also formerly commemorated by a hatchment in this church bearing the arms of **Smith** and **Heriz** quarterly impaling **Waite**, now no longer here. The monument to her second husband was formerly on the West wall of the South aisle. This lady bequeathed £5 each to the parishes of Edmondthorpe and Woodford for their poor; and 2s. 6d. each to as many poor widows of the parish of St. Andrew's, Holborn, as she was years old at her death; legacies to her first husband's godchildren; to **Edward Smith**, her second husband's eldest son, her "silver collidge pott;" "one broade piece of **Elizabeth's** gold" to the Countess of Kenwarth; also money and jewels to several relations and friends.

(b)

Olivia Smith, the donor of the silver dish, was the daughter of **Thomas Pepys**, Esq., of Merton Abbey, Surrey, by **Ursula**, daughter of **Bryan Stapleton**, of Myton, co. York. She was married in 1683† to **Edward Smith**, eldest son of **Sir Edward Smith**, 1st Bart. of Edmondthorpe, by his first wife, **Constantia Spencer**, who succeeded his father as 2nd Bart. **Olivia, Lady Smith**, died on 6th June, 1710, aged 45, having borne her husband one son who died an infant. **Sir Edward Smith**, a few weeks before his death, married at Edmondthorpe, on 26th Jan., 1719-20, **Eleanor Fardell**, of this place:‡ he died on 17th Feb., 1720, aged 66. Against the South wall of this church is a large monument of grey and white marble to **Sir Edward** and his first wife, **Olivia**; in the upper part of which are the arms of **Smith** and **Heriz**, quarterly; and on an *escutcheon of pretence*; *Sable, on a bend Or, between two horses heads erased Argent, three fleur-de-lis of the field*: **Pepys**. I have failed to find **Olivia Lady Smith's** will.

(d)

Mrs. Smith, the donor of the two handsome flagons, was **Margaret**, the eldest daughter and co-heir of **Edward Horsman**, Esq., of Stretton, co. Rutland, by his second wife, **Alice**, daughter and co-heir of **Sir John Oldfield**, Bart., of Spalding, co. Lincoln, and was born at Stretton on 12th July,

* For pedigrees, see *Nichols*, Vol. ii., p. 184.† Licence dated 14th June. *Publica. of the Harl. Soc.*

Vol. xxiv., p. 166. ‡ Parish Register.

1708, and baptized on 10th Aug.* She was married at Stretton* on 31st Jan., 1730, to **Edward Smith**, Esq., LL.D., the eldest son of the Rev. **Roger Smith**, rector of Husband's Bosworth, who was the grandson of **Roger Smith**, of Frolesworth, the third son of Sir **Roger Smith**, Knt., *alias* Heriz, the purchaser of Edmondthorpe. Mr. **Edward Smith**, at the age of 15 inherited the family estates in this parish and elsewhere, from his distant cousin Sir **Edward Smith**, 2nd Bart. He was a man of considerable ability and was held in much esteem by the people of this county, who chose him as one of their members of parliament from 1734 till his death, without issue, on 15th Feb., 1762. His widow, the donor of these flagons, survived until 30th March, 1780. Both were buried in Edmondthorpe church.

To the memory of **Edward Smith**, LL.D., is a mural monument of many marbles, on the South wall of the South aisle, on which are the arms of **Smith** and **Heriz**, quarterly; and on an escutcheon of pretence, Quarterly, 1 and 4. Or three sinister gauntlets Sable, **Horsman**. 2 and 3. Or, on a pile Vert three garbs of the field, **Oldfield**. On the opposite side of the aisle is a small mural monument to **Margaret**, his widow, on which are these words: "*She was truly religious, and had every virtue to adorn her sex.*" This tablet was originally over the door;†

With the death of this lady there came to an end the last link which had for so long connected this parish with the ancient family of **Smith** or **Heriz**. At the death of her husband his estates had been sold to **W. Pochin**, Esq., of Barkby.

GARTHORPE.

SILVER CUP. Weight 9.5 oz. Height $7\frac{3}{8}$ in. Diam. of the bowl $3\frac{3}{8}$ in.; of the foot $3\frac{1}{4}$ in. Height of the stem $2\frac{2}{3}$ in. Date 1709.

Hall marks. 1. Court hand O in pointed shield. 2. Lion's head erased. 3. Britannia. 4. H. I., pellet above, and possibly a crescent below; the I is indistinct. Mark probably of *William Hinton*.

This cup has a straight-sided bowl with a lip slightly bell-shaped, and a plain round stem, without a knob, swelling out to both ends. The foot is quite plain, with the lion's head erased repeated underneath.

SILVER PATEN with a foot. Weight 5.9 oz. Diam. $5\frac{3}{4}$ in. Diam. of the foot $2\frac{1}{2}$ in. Height of the foot $1\frac{3}{4}$ in. Date 1726.

Hall marks. 1. Capital Roman L in an irregular shaped stamp. 2. Large leopard's head crowned, in an oval shield. 3. Lion passant, in a plain oblong. 4. Capital Roman M, with a mullet below the right-hand stroke.

This paten has a low and narrow rounded edge, from which the middle part is sunk a little, perfectly flat. Its foot, which is hollow, ends in a round moulding and flat edge.

SILVER FLAGON. Weight 27.7 oz. Height $6\frac{3}{8}$ in. Diam. at the top 5 in.; at the bottom $5\frac{5}{8}$ in. Date 1673. (PLATE II.)

* Parish Register.

† For monumental inscriptions, vide *Nichols*, ante.

Hall marks. 1. Capital old English Q in a pointed shield. 2. Lion passant. 3. Leopard's head crowned, each of the two last having an outer line following the outline. 4. I. D., in a shaped oblong.

This is a short, wide, and straight-sided tankard, narrowing slightly towards the top. The lid has a flat top, slightly raised above a flat projecting edge, which edge is shaped in front into a point, to be taken hold of in opening the lid. Round the inside of the lid is a vertical rim $\frac{1}{2}$ of an inch deep, fitting the lid on to the drum. The handle is a large thick one of the usual shape, the maker's mark being stamped on the back of it. In front of the drum are these arms: *Three bars impaling; Gules a fesse Ermine between three water boujets Argent, Meres,*

There was formerly in the register here a copy of the terrier made in 1708, which is printed by *Nichols* (Vol. ii., p. 191.) in which the church plate is thus spoken of; "a pewter flagon; one silver cup weighing about 9 $\frac{1}{2}$ oz.; one silver paten weighing about 2 $\frac{1}{2}$ oz. N.B.—The silver cup has been since changed and made larger." From this note it seems that the old cup, possibly an Elizabethan one, was worked up again into the one now here, which is not much heavier than the former one though larger in size; at the change, if the old metal was used again its standard of purity was of course raised.

From the terrier of 1724 at Lincoln, we learn that the little paten, no doubt a cover paten to the old cup was still here; it probably went when the new paten came two years later. In any case only the present paten is mentioned in the terrier of 1745; which document, by the bye, contains no notice of the silver flagon, the pewter one only being named. The terrier of 1821 names "one silver cup, one silver chalice and paten:" the "chalice" probably represents the flagon now here.

All that I can say about this flagon is that when first made it belonged to some one who married a **Meres**, and that it was given or bequeathed to this church between 1745 and 1821.

GOADBY MARWOOD.

SILVER CUP. Weight 5.2 oz. Height 5 $\frac{1}{8}$ in. Diam. of bowl 3 in.; of foot 2 $\frac{3}{4}$ in. Height of stem 2 $\frac{1}{2}$ in. Date 1567. (PLATE 13.)

Hall marks. 1. Small black letter K, with annulet below, in plain shield. 2. Leopard's head crowned. 3. Lion passant; each in shaped outline. 4. An oblong eight-pointed mark, in shaped outline.

This pretty little cup, made by the same maker and in the same year as the Foxton and Kimcote cups, is similar to them in shape, having a bowl shaped into an inverted truncated cone, with sides bulging out, and a bell-shaped lip, below which runs a raised moulding. It has a plain short stem, swelling out into a vertical edge ornamented with reeds, the egg and tongue ornament running round the edge of the foot.

(a)

SILVER PATEN with a foot. Weight 5 oz. Diam. $5\frac{3}{4}$ in. Diam. of foot $2\frac{5}{8}$ in. Height $1\frac{7}{8}$ in. Date 1717.

Hall marks. 1. Capital Roman B. 2. Britannia. 3. Lion's head erased. 4. P, rest illegible.

This is a plain flat paten, with a hollow foot, having an ovolo moulding round its edge.

(b)

SILVER CUP. Weight 12 oz. Height $7\frac{3}{8}$ in. Diam. of bowl $3\frac{1}{4}$ in.; of foot $3\frac{7}{8}$ in. Height of stem $4\frac{7}{8}$ in. Date 1883.

London hall marks.

This is an imitation mediæval cup, ornamented with engraved foliage, having an hexagonal stem, knob, and foot, underneath which latter is: *Given for the use of Goadby church by B. L. and L. P. P. 1883.*"

SILVER PATEN. Weight 4 oz. Diam. $5\frac{1}{4}$. Date 1883.

This paten corresponds to the modern cup. In its centre is the sacred monogram within an ornamental border, and round its edge is a trefoil ornament. Underneath is: "*Lord remember me;*" and "*Given for the use of Goadby church, 1883.*"

The cover paten belonging to the old cup did not exist in 1832; it was probably parted with when the paten was given.

(a)

We learn from a note made by Mr. Peck, and recorded in *Nichols* (Vol. ii., p. 197) that the paten was the gift of Elizabeth, wife of the Rev. Edmund Carter, M.A., rector of this parish.

According to *Nichols* she was sister to Mr. Tate, of Burleigh; in that case she must have been a daughter of Anthony Tate, of Sutton Bonnington,* by Bridget, daughter of Henry Kilby, and was therefore aunt to Mary Butler.† She married‡ at Loughborough, on 24th June, 1700, the Rev. Edmund Carter, of that place,§ an M.A. of Emmanuel College, Cambridge, who was instituted to the living of Goadby four days after his marriage. Mr. Carter took the degree of D.D. in 1721, and died on 2nd Dec., 1722, aged 50, being buried in the chancel of this church on the 4th.¶ His wife had died in the year before, and was buried on 12th Oct.¶ She bore her husband two sons, Henry, baptized here on 28th Oct., 1703, and Abraham, baptized on 28th Sep., 1704.¶ To the eldest letters of administration were granted, on his father's death, at Leicester on 11th Dec., 1722.

(b)

The two modern pieces were presented by the brother-in-law and sister of the late rector, the Rev. C. Bellairs, viz., the late Benjamin Lancaster,

* "Anthony Tate, gent., buried 29th April, 1682;" "Bridgett Tate, gentlewoman, buried 21st Oct. 1684;" Sutton Bonnington parish register. + Loughborough, p. 46.

† Marriage bond issued at Leicester on 20th June, 1700; Edmund Carter of Loughborough, Clerk, æt. 28, Batch., and Elizabeth Tate, of Burleigh in Loughborough Spint., æt. 27. § Parish Register. ¶ Parish Register.

and **Laura Parker Price**, widow of the late Capt. **John A. Price**, R.N., which lady is now living at Bournemouth.

Mr. **Benjamin Lancaster** was one of the younger sons of **Robert Lancaster**, Esq., by his wife, **Mary Brunton**, and was born in London, on 1st Dec., 1801. As a young man he became a clerk in the office of Mr. **Wilson**, the head of a Russian mercantile business. He was taken into partnership and made a large fortune. Mr. **Lancaster** will be handed down to memory as a devoted churchman who gave with the utmost liberality both money and time to many good works. It would be totally impossible to mention here all the many benefactions which he bestowed on charitable objects: for an enumeration of that kind is prevented by the modesty with which he made his gifts. The best known memorials of his bounty are St. Peter's Home, Kilburn, which he built and endowed; and the hospital for incurables which he erected at Woking, in memory of his wife, but did not live to see quite completed. He contributed largely towards the building of All Saints' church, Margaret Street, and the church of St. Augustine, Kilburn. Mr. **Lancaster** died without issue at Bournemouth, where he had been living for some years, on the 16th April, 1887, and was buried in Willesden cemetery on the 22nd. He married, on 5th June, 1851, **Rosa Mira**, one of the daughters of the Rev. Canon **Henry Bellairs**, rector of Bedworth, co. Warwick, which lady died on 11th Jan., 1874.* Mrs. **Lancaster** was a true "yoke fellow" with her husband in all his schemes for the good of others; many of which were originated by herself.

SAXBY.

SILVER CUP. Weight 6.3 oz. Height $6\frac{1}{2}$ in. Diam. of bowl $3\frac{3}{8}$ in.; of foot $3\frac{1}{4}$ in. Height of stem 3 in. Date *circa* 1570. (PLATE 10.)

Traces of one very indistinct mark.

This cup has a nearly straight-sided bowl, with a lip slightly bell-shaped, and a flat base; a plain round stem without a knob, swelling out at both ends into vertical edges, round which run lines, and a foot of the usual shape. It was made, we may conclude, by the maker using the leopard's face as his mark; its bowl is wider and its stem higher than others of this series.

SILVER PATEN with a foot. Weight 2.1 oz. Diam. $3\frac{1}{2}$ in. Diam. of foot $1\frac{3}{8}$ in. Height 1 in. Date *circa* 1570. (PLATE 10.)

One mark only, a leopard's face in a shaped stamp.

This paten has a narrow flat edge, without a rim, from whence it is slightly sunk. The foot is a disk, attached to the paten by a stem swelling out at both ends. A few years ago this paten was repaired, when its edge may perhaps have been made narrower and the rim taken off.

* For pedigree of Bellairs, see *Leicestershire Pedigrees*, by W. G. D. Fletcher, p. 22.



Fig. 13. Circa 1610. Full size. M.P. del.

PEWTER FLAGON. Height 14 in. Diam. at the top $3\frac{1}{2}$ in.; at the foot $5\frac{3}{4}$ in.

No marks.

This is a tall, narrow, straight-sided flagon, with a lid raised into a knob, and an R shaped handle.

PEWTER PLATE. Diam. $8\frac{3}{4}$ in.

Marks. On edge. 1. M. S. 2. In four small shapes: (a) E. L. (b) A garb, I think. (c) Leopard's face. (d) A buckle. On the back. 1. Rose crowned. 2. Two foxes sejant, facing one another, crowned. 3. "London."

PEWTER PLATE. Diam. $9\frac{1}{4}$ in.

Marks. On the edge, 1. Saxby. 2. R. B. On the back, X crowned, and other indistinct marks.

STAPLEFORD.

(a)

SILVER GILT CUP AND COVER. Weight of both 12.1 oz. Height with cover on $8\frac{1}{2}$ in. Diam. of the top of the bowl $1\frac{7}{8}$ in.; of the foot $2\frac{5}{8}$ in. Height of stem $3\frac{3}{4}$ in. Date circa 1610. (FIG. 13.)

No marks; unless there is a very faint trace of a maker's initial on the loose piece under the bowl.

This beautiful little cup, probably of German make, has a bowl and cover in the shape of an acorn, with an oak twig for a stem, which rests on a foot very similar in design to the feet of the hanaps made in the early years of the 17th century. On one side of the bowl are engraved the donor's arms; *Argent a chevron Gules between three torteaux*; Supporters; *Two rams Argent, armed, and unguled, Or*;

Sherard; Motto; "*Hostis honori invidia*;" an Earl's coronet above. On the opposite side is: "*This cup left to ye church of Stapleford by ye Rth Hon^{ble}. Bennet, Earl of Harborough: Who departed this life, Oct. 16, 1732.*" On one side of the cover is the sacred monogram, with a cross and three nails within a circle of glory. On the other side is the donor's crest; *Out of a ducal coronet, Or, a peacock's tail erect, Ppr.*: an Earl's coronet above. The stem and foot take to pieces.

(b)

SILVER CUP. Weight 10.3 oz. Height 8 $\frac{3}{4}$ in. Diam. of the bowl 4 $\frac{1}{2}$ in.; of the foot 4 in. Height of stem 3 $\frac{1}{2}$ in. Date 1692.

Hall marks. 1. Small black letter P in a plain shield. 2. Leopard's head crowned, in a circle. 3. Lion passant in a plain oblong. 4. R.C., three pellets both above and below, within a dotted circle.

This cup has a deep and nearly straight-sided bowl, swelling out into a bell-shaped lip. Its stem is divided above the middle by a small round moulding on a fillet, from whence it swells into the bowl and into the foot, round which is an ovolo moulding. On one side of the bowl is the sacred monogram, with a cross, heart, and three nails, within a circle of glory. On the other side these arms in a lozenge: *Ermine on a fesse Gules, three escallops Or. Ingram impaling Sherard; a Viscount's coronet above.* (FIG. 14.) Under the arms is: "*The Gift of the Right Hon^{ble}. the Lady Viscountess Irwin, to the Parish Church of Stapleford, Anno 1692, Lestershire.*"



Fig. 14.

SILVER PATEN with a foot. Weight 5.4 oz. Diam. 6 in. Diam. of foot 2 $\frac{1}{2}$ in. Height $\frac{3}{4}$ in. Date 1692.

Same hall marks as on cup.

This paten has a wide flat edge, round which is the same inscription as that on the cup: the centre, which bears the same arms, is sunk flat, so as to allow the paten to fit on the cup with its foot downwards; the latter is a disk, bearing the sacred monogram, etc., and attached to the paten by the usual stem.

(c)

SILVER GILT CUP AND COVER PATEN. Weight of cup 14.3 oz. Height 6 $\frac{1}{2}$ in. Diam. of bowl 3 $\frac{1}{2}$ in.; of foot 3 $\frac{3}{8}$ in. Height of stem 3 $\frac{1}{4}$ in. Date 1738.

Hall marks. 1. Capital Roman C, in a plain shield. 2. Leopard's head crowned, in a plain shield. 3. Lion passant, in plain oblong. 4. A.V., pellet above, in shaped oblong.

This cup has a straight-sided bowl, with a rounded base and raised lip, standing on a straight stem swelling out a little at each end, and divided in half by a small moulding for a knob. On the bowl are the arms of **Sherard**: *Impaling; Gules a chevron vairé Or and Azure, between three roses Argent, barbed and seeded Ppr.*: **Reeve.** (FIG. 15.)



Fig. 15.

SILVER GILT COVER PATEN. Weight 3.1 oz. Diam. 3 $\frac{3}{4}$ in. Diam. of foot 1 $\frac{1}{4}$ in. Height $\frac{3}{8}$ in. Date 1738.

Mark. Lion passant only.

This is a rounded cover with deep moulded rim, allowing it to fit both ways on to the

cup. Its foot is a disk, attached to the paten by a round stem. On the outside of the cover is engraved the **Sherard** crest.

(d)

SILVER DISH. Weight 7.8 oz. Diam $7\frac{1}{4}$ in. Date 1762.

Hall marks. 1. Capital old English G, in a plain shield. 2. Leopard's head crowned, in an oval shield. 3. Lion passant, in a plain oblong. 4. W.S., a pellet between, within an oval. Mark of *William Shaw*.

This is a plain dish, with this inscription round the edge: "*The Gift of Mrs. Elizth. Stover, Widow.*"

Nichols (Vol. ii. p. 339) mentions, quoting from notes made by Mr. **Peck**, in 1725, that until Lady **Irwine's** gift was made, the communion plate here consisted of pewter vessels, with the exception of "one old small silver cup."

This latter was probably parted with in the last century; it was at any rate not here in 1832.

(a)

The acorn cup was left to this church in the following clause in the will of **Bennet**, 1st Earl of **Harborough**, made 27th May, and proved P.C.C. 2nd Nov., 1732: "*I give my gold cup, which is in the shape of an acorn, to be kept by my family at Stapleford for the use of the church at Stapleford, to be used at the Communion there.*" This gentleman was the second but eldest surviving son of **Bennet**, 2nd Lord **Sherard**, of Stapleford, by **Elizabeth**, only daughter and heir of Sir **Robert Christopher**, Knt., of Alford, co. Lincoln, and was born at Stapleford on 9th Oct., 1677, and baptized on the 27th. On the death of his father in 1699 he succeeded to the title of Baron **Sherard**, in the peerage of Ireland, and became the representative of this ancient family, which was first settled in this parish early in the 15th century. In the last year of **William III.** Lord **Sherard** was elected M.P. for the county of Leicester, and in the last year of **Queen Anne** he filled the same office for the county of Rutland. Upon the accession of **George I.** he was made a peer of Great Britain with the title of Baron of **Harborough**, in the county of Leicester. On 21st Oct., 1728, he was made Viscount **Sherard**, of Stapleford, and on 8th May following Earl of **Harborough**, with remainder to **Philip Sherard**, of Whissendine. He was Lord-lieutenant of the county of Rutland from 12th Sep., 1715, and lord warden and justice in Eyre, North of Trent, from 3rd May, 1719, till his death on 16th Oct., 1732. Lord **Harborough** married on 30th April, 1696, in **Henry VII.** chapel, Westminster, **Mary**, daughter and co-heir of Sir **Henry Calverley**, Knt., of Ayerholme, in the Bishopric of Durham, by which lady, who died on 20th May, 1702, he had an only child, **Bennet**, who died an infant; as the Earl remained a widower, he was succeeded by his cousin, **Philip Sherard**, of Whissendine, who became 2nd Earl of **Harborough**.

Bennet, Earl of **Harborough**, bequeathed £3 each to the poor in the parishes of Stapleford, Saxby, Whissendine and Teigh; £5 each to the poor of Melton and Oakham; £2 each to the poor of Gunby and Stainby, co. Lincoln. He also left to trustees a house in this parish, to be converted into an almshouse for six poor men, whom he endowed with £8 a year each, charged on his estate. He appointed his sister **Lucy**, Duchess of **Rutland**, his sole executrix, and desired her to erect in Stapleford church a monument to himself and his father and mother, at a cost of not less than £300. A large handsome monument by **Rysbrack**, bearing effigies of himself and his wife, with their infant child, was accordingly placed against the North wall of the **Sherard** chapel attached to the South side of the old church. When the present church was built this monument was placed in its present position on the North side of the chancel.*

(b)

The donor of the silver cup and paten was the eldest sister of the above **Bennet**, 1st Earl of **Harborough**, and was born at Stapleford on 18th Aug., 1669, and baptized there on 10th Sept. Lady **Elizabeth Sherard** was married first to **Edward Ingram**, 2nd Viscount **Irwine** in the peerage of Scotland, the representative of the **Ingrams** of Temple Newsam, co. York: the sole issue of which marriage was one daughter, **Katherine**, who was born at Stapleford on 7th Aug., 1687, and died on 6th Nov., 1688. Viscount **Irwine** died shortly before his only child, on 16th Sept., 1688, in the 26th year of his age.†

He was buried in the Temple Newsam chapel attached to Whitkirk church; in which his widow placed a large monument to his memory in black and white marble, upon which are full sized effigies of himself reclining on a couch, and of his wife and child, who are represented as mourners at his side. Viscount **Irwine** dying without male issue, was succeeded by his brother **Arthur Ingram**, from whom was descended in the female line, the late **Hugo Charles Meynell Ingram**, Esq., of Temple Newsam, and of Hoar Cross Hall, co. Stafford, whose widow, the Hon. Mrs. **Meynell Ingram**, is the present owner of the ancient seat of the **Ingrams** of Temple Newsam.

Elizabeth, Lady **Irwine** married secondly, in 1696, the Hon. **John Noel**, of Luffenham, co. Rutland,‡ the fourth and youngest son of **Baptist Noel**, 3rd Viscount **Campden**, by his fourth wife **Elizabeth Bertie**, eldest daughter of Earl **Lindsey**. Soon after his marriage Mr. **Noel** bought the estate of **Walcot**, co. Northants. He was returned M.P. for Rutland, in 1710, but declared by the House of Commons to have been unduly elected. He was re-elected by the same county in 1714, and represented that constituency until his death. He was buried at **Exton** on 5th Jan., 1719, aged 59.§

Mr. **Noel** had issue by the Lady **Irwine**, four sons and three daughters, the eldest of the family being **Elizabeth**, who was born at Stapleford on 20th Feb., 1698; two of the former lived to represent the same constituency in parliament as their father had done; but from neither the sons or the daughters of Lady **Irwine** are there now any living descendants.

* Figured in *Nichols*, Vol. ii., p. 342. † His will, made 22nd Aug., 1688, was proved in the prerogative court of York, on 22nd June, 1689. ‡ Licence dated 27th May. *Pub. Harl. Soc.*, Vol. xxiv.

§ For pedigree of Noel, see *History of Market Harborough*, by J. H. Hill, F.S.A., p. 217.

Having survived her second husband for some years, Lady **Irwine** died in London, and was buried by the side of her first husband in Whitkirk church, co. York, on 16th March, 1746-7.*

(c)

The arms on the silver gilt cup and cover tell that this piece must have been first bought from some other church, and afterwards given to Stapleford church, by the Rev. the Hon. **Robert Sherard**, and his second wife **Jane Reeve**, between 1767 and 1770. **Robert Sherard**, was the third son of **Philip**, 2nd Earl of **Harborough**, by **Anne**, daughter and heir of **Nicholas Pedley**, Esq., and was born on 21st Oct. 1719. He proceeded from Merton College, Oxford, to the degree of B.A. in 1740, and M.A. in 1743. Entering holy orders, he became rector of Teigh, co. Rutland, and of Weston, co. Huntingdon; he was also a canon residentiary of Salisbury and a prebendary of Southwell. Upon the death of his eldest brother, **Bennet**, 3rd Earl, on 24th Feb., 1770, he succeeded to the title and estates of his family, as 4th Earl of **Harborough**.

In 1783, **Robert**, Earl of **Harborough**, entirely rebuilt Stapleford Church, leaving it as it now is. He also in the same year, built a better house on a different site for the bedesmen endowed by the 1st Earl, and increased their allowance. Six years later he rebuilt the church at Saxby and the rectory house there, both of which still exist to bear witness to his liberality.

The Earl was thrice married; first on 17th May, 1762, to **Catherine**, eldest daughter and co-heir of **Edward Hearst**, Esq., of Salisbury, who died, leaving no issue, on 5th Feb., 1765; secondly on 2nd Jan., 1767, to **Jane**, daughter of **William Reeve**, Esq., of Melton, by his wife, **Jane**, daughter of **Ellis Key**, of Leadenham, co. Lincoln, who died at Bath, on 9th Nov. 1770, aged 29, leaving a son **Philip**, afterwards 5th Earl, and two daughters; thirdly on 25th May, 1772, to **Dorothy**, daughter and heir of **William Roberts**, Esq., of Glaston, co. Rutland, who died at Bristol, on 16th Sep., 1781, leaving a daughter, who died an infant. The Earl himself died on the 25th April, 1799, and was buried in Stapleford church, where there is a bust to his memory.†

(d)

Elizabeth Storer, the donor of the silver dish, was the widow of the Rev. **Francis Storer**, M.A., who was baptized at Buckminster, on 13th Oct., 1691,‡ being the son of **Edward Storer**, M.B., of that place. **Francis Storer** was presented to the vicarage of Stapleford in 1717,§ and to the rectory of Saxby in 1728: by his wife **Elizabeth**, he had a son, **Bennet**, baptized at Stapleford, on 21st Nov. 1726, afterwards rector of Harby and a prebendary of Canterbury; and a daughter, **Catherine**, baptized on 24th

* Parish Register. † For pedigree of Sherard, vide *Nichols*, Vol. ii., p. 346. ‡ Parish Register.

§ *Ibid.* pp. 127, 213, 311, 359.

Feb., 1728-9. Mr. **Storer**, who held both livings till his death, was buried at Stapleford on 11th May, 1745,* his widow, **Elizabeth**, on 31st May, 1765.*

In his will, made on 2nd Nov., 1731, and proved in Leicester on 3rd June, 1745, **Francis Storer** "of Stapleford," left to his wife **Elizabeth** the use of all his real and personal estate for life; after her death one half of that estate to his son **Bennet Storer**, together with his "study of books," and the other half of his real and personal estate to his daughter, **Catherine Storer**. To the poor of Stapleford and Saxby, £2 for each parish. His wife guardian of his children till they are 21, after her death **Philip Sherard**, Esq., of Whissendine, then "sister" **Bacon**. Wife sole executrix. Seal: *Lion rampant, tail noised, Storer, impaling; two bars.*

STONESBY.

SILVER CUP AND COVER PATEN. Weight of cup 5.7 oz. Height 5 $\frac{3}{4}$ in. Diam. of bowl 3 $\frac{3}{8}$ in.; of foot 2 $\frac{7}{8}$ in. Height of stem 2 $\frac{3}{8}$ in. Date *circa* 1570. (PLATE 10.)

One mark only, leopard's face in a shaped shield.

This cup is almost exactly like the one at Saltby;† it has the same shaped bowl standing on a plain straight stem, swelling out at each end, the egg and tongue ornament running round the foot.

SILVER COVER PATEN. Weight 1.5 oz. Diam. 3 $\frac{1}{4}$ in. Date *circa* 1570. (PLATE 10.)

No marks.

This cover is of the usual Elizabethan shape, having a broad engraved band round its top, divided into four parts by hour-glass curves, the straps enclosing five rows of little horizontal strokes. The button has been broken off; its short stem still remains; this rises out of three disks placed one over the other on the top of the paten.

SILVER PLATED PATEN. Diam. 6 $\frac{1}{4}$ in.

In the centre is the sacred monogram, and on the back: "*J. Snodin, J. Geeson, churchwardens. J. P. Seabrook, M.A., Vicar, 1882.*"

PEWTER FLAGON. Height 8 $\frac{1}{4}$ in. Diam. at top 3 $\frac{3}{8}$ in.; at foot 3 $\frac{7}{8}$ in.

Mark on lid, W.R. crowned.

This is a thick tankard, with a narrow drum bulging out below.

THORPE ARNOLD.

SILVER CUP WITH COVER PATEN. Weight of cup 16.9 oz. Height 8 in. Diam. of bowl 5 $\frac{3}{8}$ in.; of foot 5 in. Height of stem 3 $\frac{3}{4}$ in. Date 1668.

Hall marks. 1. Capital old English L in a plain shield. 2. Lion passant; 3. Leopard's head crowned, each within shaped lines. 4. M. interlaced in monogram, crowned, within a shaped oblong.

This large cup has a straight-sided bowl with a flat base, standing on a plain round stem swelling out into a foot, rounded off into a flat edge; at the top of the stem is a narrow disk. On the bowl is: "*Deo et Ecclesie pietatis ergo D.D. M.L. 1668.*"

* Parish Register.

† Page 124.

SILVER COVER PATEN with a foot. Weight 6.6 oz. Diam. $6\frac{1}{2}$ in. Diam. of foot $3\frac{1}{8}$ in. Height of foot 1 in. Date 1668.

Hall marks as on the cup.

This paten has a flat edge $\frac{1}{4}$ an inch wide, from whence the main part is sunk flat. The foot is a disk, attached to the paten by a stem swelling out at both ends. Round the top is the same inscription as that on the cup, minus the date.

SILVER FLAGON. Weight 40.8 oz. Height $10\frac{3}{4}$ in. Diam. at the top $4\frac{1}{2}$ in.; at the foot 7 in.

Hall marks as on the cup.

This is a straight-sided flagon, narrowing towards the top, standing on a wide, flat, sloping foot. It has a plain handle, and flat purchase pierced with a heart. Round the drum is: "*Deo Om. et Ecclesie parochiali de Thorpe Arnold, D.D. M.L. 1668.*"

The donor of this service of communion plate was Sir **Martin Lister**, Knt., who sprang from the **Listers**, of Midhope, co. York; the younger branch of this ancient family being the **Listers**, of Gisburne, now represented by Lord **Ribblesdale**. Sir **Martin** was the son of **Michael Lister**, Esq., of Frierhead-in-Craven, co. York, by his wife, **Mary Kebell**. In early life he was a distinguished officer of the Militia, and lived at Radcliff, co. Bucks. Subsequently he settled in this parish, the lordship of which he purchased from **Arthur Waring**, Esq., before 1640, as is shown by entries in the parish register. Sir **Martin**, who was knighted at Hampton Court on 9th July, 1625, was afterwards the owner also of Burwell Park, Lincolnshire, which he inherited from his uncle, Sir **Matthew Lister**, Physician to **James I.** and **Charles I.**, who died s.p. in 1656. There he lived during the latter part of his life, having given up his house at Thorpe Arnold to his eldest son, **Richard**. Sir **Martin** died at Burwell, and was buried there on 29th Aug., 1670, aged 70. He was twice married; first to **Mary**, daughter of **Richard**, Lord **Wenmam**, of Thame, Oxon., who died *circa* 1635; by whom he had a son, **Richard**, of Thorpe Arnold, born 10th June, 1628, whose son, **Richard**, obtained the **Pate** property at Sysonby, with his wife, **Frances Pate Smith**; their son, **John Pate Lister**, sold at the end of the last century his estates both in Thorpe Arnold and Sysonby. Sir **Martin Lister**, Knt., married secondly, **Susannah**, daughter of Sir **Alexander Temple**, of St. Mary's, Hoo, Kent, and widow of Sir **Gifford Thornhurst**, Bart.; by this lady, who was buried at Burwell on 28th Nov., 1669, he had several children, some of whom were born in Thorpe Arnold; the eldest son, **Michael**, born *circa* 1637, became his successor at Burwell Park, and the ancestor of **Matthew Henry Lister**, Esq., who sold that estate in 1882, to Mr. **Hornsby**. The second son of this marriage, **Martin**, became like his great-uncle, Sir **Matthew**, by whom he was brought up, a famous physician.

No monument exists in Burwell to the donor of this service, but there is one which his

daughter, **Jane** put up to her husband, **Hugh Alington**, Esq., on which are these arms: *Sable a bend engrailed between six billets Argent; Alington; impaling; Ermine on a fesse Sable three mullets* Or; Lister.* At Denton Hall, Lincolnshire, there is a picture of **Sir Martin Lister**, and also one of his second wife painted by **Cornelius Jansen** during the life-time of her first husband; both these were engraved by **R. White** in 1626. These pictures came into the possession of the **Gregory** family, owing to the marriage of **Sir Martin's** daughter **Susannah**, with **George Gregory**, of Nottingham, on Jan 21st, 1663.

BRENTINGBY.

SILVER CUP. Weight 4.3 oz. Height $5\frac{3}{4}$ in. Diam. of the bowl $3\frac{1}{2}$ in.; of foot $3\frac{1}{4}$ in. Height of stem $2\frac{7}{8}$ in. Date *circa* 1570. (PLATE II.)

No hall marks.

This pretty little cup has a short, bell-shaped bowl, resting on a thick, evenly-balanced stem, divided in half by a large round knob on a narrow fillet, from whence it swells out into vertical edges reeded. The foot is high, and rounded off into a flat sloping edge. Round the middle of the bowl is a band of extremely graceful foliage, which is undivided by curves.

PEWTER PLATE. Diam. $8\frac{3}{4}$ in.

Marks. 1. On the edge in three square shapes: (a) Imperial crown. (b) Star. (c) "T—" with a cinquefoil above. 2. On back: An anchor crowned, 16, to the left, two leaves below, much worn.

This plate has a flat edge, with narrow mouldings round edge.

PEWTER FLAGON. Height 8 in. Diam. at top $3\frac{3}{8}$ in.; at foot $4\frac{1}{2}$ in.

Mark, inside on bottom, S.B., in a diamond stamp.

This is a short, straight-sided flagon, narrowing to the top, with a few round mouldings round the drum. It has a flat lid, with its edge projecting into a point in front. The purchase is formed with two birds facing one another.



Fig. 16. *Circa* 1610. About $\frac{1}{2}$ of full size. M.P. del.

WALTHAM-ON-THE-WOLDS.

SILVER GILT CUP AND COVER. Weight of cup 10.8 oz. Height $9\frac{1}{2}$ in. Diam. of bowl $3\frac{3}{8}$ in.; of foot $3\frac{1}{2}$ in. Height of stem $4\frac{1}{4}$ in. Date *circa* 1610. (FIG. 16.)

Marks. On the lip. 1. N in a round stamp; Nuremberg mark. 2. L.T. in a plain oblong. On the foot, 1. Small pine apple; Augsburg mark. 2. Angular double hook between two pellets.

This cup has a deep and nearly straight-sided bowl, with a flat base, standing on a short baluster stem, supported by three brackets. The stem rises out of a high globular foot with a wide edge. The whole cup is repoussé with arabesques of fruit and flowers. Round the upper part of

* Not annulets as in *Nichols*, Vol. ii, p. 376

the bowl are three winged cherubs' heads, over each of which is what appears to be a baldichino.*

SILVER GILT COVER. Weight 8.9 oz. Height $4\frac{1}{2}$ in. Diam. 4 in. Date *circa* 1610.

Mark. L. T. in a plain oblong.

This rather shallow cover is surmounted by an evenly-balanced pedestal, on which stands a warrior holding in his right hand a tall halberd and in his left a shield, bearing a cross moline. The cover is repoussé in a similar style to the cup; three fleur-de-lis, and three groups of fruit, are placed on the top alternately.

SILVER GILT PATEN with a foot. Weight 7.5oz. Diam. $5\frac{3}{4}$ in. Diam. of foot $3\frac{1}{4}$ in. Height of foot $1\frac{1}{8}$ in. Date 1842.

London hall marks.

In the centre is the sacred monogram and "*Evermore give us this bread,*" in Greek.

SILVER GILT ALMS BASIN. Weight 16.3 oz. Diam. $9\frac{1}{2}$ in. Diam. at foot $4\frac{1}{4}$ in. Depth $2\frac{1}{4}$ in. Date 1843.

London hall marks.

In the centre is a cross in relief, bearing the symbols of the four evangelists; round which is; "*All things come of thee, and of thine have we given thee; 1 Chron. xxix. 14.*"

SILVER GILT FLAGON. Weight 39.9 oz. Height $12\frac{1}{2}$ in. Diam. at the top $3\frac{7}{8}$ in.; at the foot 6 in. Date 1842.

London hall marks.

This is a straight-sided flagon narrowing towards the top. Its lid is surmounted by a latin cross. Round the lower part of the drum is "*Of thine own have we given thee,*" in Greek. Under the foot is "*Parish Church of St. Mary Magdalene, Waltham, Dioc. of Peterborough, Deanery of Framland, co. Leicester, 1842.*"

These three modern pieces are each elaborately repoussé, with winged cherubs and arabesques in imitation of the ancient German cup and cover. The design, however, is in detail considerably coarser.

PEWTER FLAGON. Height $11\frac{3}{4}$ in. Diam. at the top 4 in.; at the foot $6\frac{1}{4}$ in.

Marks. 1. X crowned. 2. In four small shapes: (a) Lion passant. (b) Lion passant. (c) H. I. (d) Illegible mark.

This is a straight-sided flagon, narrowing to the top. It has an R shaped handle, and a raised lid narrowing into a round knob.

PEWTER BASIN. Diam. $9\frac{1}{2}$ in. Depth $3\frac{3}{4}$ in.

Mark. X crowned, with an indistinct mark below, repeated twice.

In the Waltham terrier at Lincoln for 1708, the communion plate is thus described; "one silver communion cup, weight $9\frac{1}{2}$ oz.: one pewter flagon and large plate of pewter."

An entry in one of the registers records the purchase of the present service. The covered cup was bought from Mr. Lambert, in 1842, for

* I am indebted to Mr. Cripps for the suggestion that this cup may possibly be made up out of two, the bowl being taken from a Nuremberg cup that had lost its stem, and the stem from some Augsburg piece of about the same date.

£14 10s., and the flagon from Mr. **Willmore**, for £31 11s. 6d. In the year following, the paten and alms basin were bought from the latter, for £13 10s. 6d., and £18 15s. respectively. The cost of this service was defrayed by offerings and donations, and the value of the old cup, which was sold to Chadwell church. This service was presented to the church during the incumbency of the Rev. **Gabriel Edwards Gillett**, M.A., who was rector here from 1831 to 1871; and, during whose time, many improvements were made in the fabric of the church. Mr. **Gillett** was elected in 1850 a Proctor in Convocation for the Diocese of Peterborough.

WYFORDBY.

SILVER CUP. Weight 5.9 oz. Height 6 in. Diam. of bowl $3\frac{1}{2}$ in.; of foot $2\frac{7}{8}$ in. Height of stem $2\frac{1}{4}$ in. Date *circa* 1570. (PLATE 10.)

Marks. A female head couped at shoulders? within a shaped shield, between G.N., mark and letters being all upside down.

This little cup has a bowl nearly straight-sided in the lower part swelling out higher up into a bell-shaped lip, standing on a plain round stem which swells out at each end into vertical edges round which run horizontal lines. The foot is of the usual shape with the egg and tongue ornament running round its edge. Some years ago the dints were beaten out of this cup.

SILVER FLAGON. Weight 41.5 oz. Height 12 in. Diam. at the top $4\frac{1}{2}$ in.; at the foot $6\frac{5}{8}$ in. Date 1676. (FIG. 17.)

Hall marks. 1. Capital old English L in a plain shield. 2. Leopard's head crowned. 3. Lion passant, each within a shaped line. 4. I.M. three pellets above and below within a dotted circle.

This is a large straight-sided flagon, having a purchase pierced with two triangles. In front is "*Deo et Ecclesie de Wyfordby, D.D. Tho: Briggs, LL.Dr. et Cancell Ciscestre. Filius Tho. Briggs, quondam Rectoris hujus ecclesie. Ano salutis 1677.*"

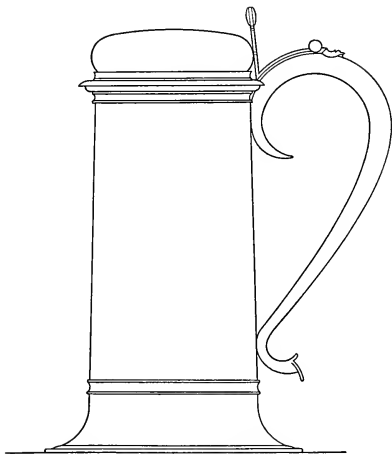

Fig. 17. Date 1676. About $\frac{1}{4}$ of full size. M. P. del.

SILVER PATEN with a foot. Weight 5.5 oz. Diam. $5\frac{5}{8}$ in. Diam. of foot $2\frac{3}{8}$ in. Height of foot $\frac{3}{4}$ in. Date 1676.

The same maker's mark as that on the flagon is the only mark on this piece.

In shape this paten is a shallow basin. Its foot is a disk attached to the paten by a round stem swelling out at each end. Round the top of the paten is the same inscription as that on the flagon.

PEWTER PATEN. Diam. $6\frac{7}{8}$ in.

Marks. 1. On the top in four small shapes: (a) Lion passant. (b) Crab. (c) Buckle. (d) Fleur-de-lis. 2. On the back W, interlaced within a heart-shaped shield.

This paten, which was evidently used as such before the silver one was given, is flat, with a raised edge.

The lord of the manor here, and at Brentingby in 1670, was **George Smith**, of Ashby Folville.

Thomas Briggs, the donor of the flagon and paten, was the eldest son of the Rev. **Thomas Briggs**, rector of this parish from 1625, till his death in Oct., 1644, by his wife, **Frisworth**, and was baptized here, on 8th Sep. 1633.* Having been educated at the Grammar School, Stamford, he was admitted as a sizar in St. John's College, Cambridge, in 1650: he became a fellow of his college, and took his degree of LL.D. from thence in 1669. Dr. **Thomas Briggs**, a lawyer by profession, settled in the city of Chichester, and was made Chancellor of the Diocese of Chichester, in 1672, which post he held till his death on 13th Oct., 1713. He was buried in the North aisle of the nave of Chichester cathedral, near the North West door, on the wall of which aisle a white marble monument was erected to his memory, which is now in the cloisters. This monument, inscribed with a short epitaph in latin, written by himself, is surmounted with a shield bearing these arms; *Barry of eight Gules and Or, on a canton Sable a crescent of the second*; **Briggs**. The donor of these two pieces of plate married **Elizabeth**, daughter and co-heir of Sir **John Stapeley**, Bart., of Patcham, Sussex; by this lady, who died in 1721, aged 63, he had an eldest son, **Thomas**, and a second son, **John**, who married **Mary**, daughter of **Henry Eedes**, Esq., of Chidham, a daughter **Barbara**, who died unmarried in 1735, aged 51, and another daughter **Elizabeth**, who married **John Shore**, M.D. Monumental slabs to some of these are still in the floor on the North side of the nave of Chichester Cathedral.

By his will dated 9th Jan., 1712, and proved P.C.C. 27th Oct., 1713, Dr. **Briggs** left £5 to the vicars and choir of Chichester Cathedral, and £5 to the poor of the sub-deanery. To his wife **Elizabeth**, and his daughter **Barbara**, he left his house in Chichester, and to the latter two houses in Bow Lane, and Doctors' Commons, London, and also the lease of the rectory of Pevensey; his wife receiving his property in Itchenor, Sussex, for life. All other houses and lands he left to his son **Thomas**, and his heirs male if any; if none, to his second son **John**, and his heirs male; if none, then to the heirs female of the former, and in default to heirs female of the latter: if neither son left heirs of either sex his daughters **Barbara** and **Elizabeth** were to succeed to his estates. His son **Thomas**, to whom he left his books, he

* Parish Register.

appointed his sole executor. The Doctor's sister, Mrs. **Holland**, and others, came in for legacies.

WYMONDHAM.

SILVER CUP WITH COVER PATEN. Weight of cup 10.2 oz. Height $7\frac{1}{2}$ in. Diam. of the bowl $3\frac{3}{4}$ in.; of the foot $3\frac{1}{2}$ in. Height of stem $3\frac{3}{8}$ in. Date **1568**. (PLATE II.)

Hall marks. 1. Small black letter **L**, in a plain pointed shield. 2. Lion passant. 3. Leopard's head crowned, each of the two last having an outer line following its outline. F.R. in monogram, within a shaped shield.

The bowl of this cup is an inverted truncated cone; its stem is evenly-balanced, with a round moulding on a fillet for a knob; the foot is as usual. Round the lip is a band, divided into four parts by hour-glass curves, within the straps of which is foliage of the usual style. Round the bottom of the bowl, at its junction with the stem, and also round both ends of the stem, is a chain ornament, formed by a row of circles, each joined to each by a horizontal line; round the edge of the foot is the more common egg and tongue ornament.

Apparently, at some former time, this cup has had a very slight piece taken off the edge of its lip; possibly this was done when its dents were beaten out.

SILVER COVER PATEN with a foot. Weight 3 oz. Diam. $4\frac{3}{8}$ in. Diam. of the foot $1\frac{3}{4}$ in. Height of foot 1 in. Date **1568**. (PLATE II.)

Hall marks as on cup.

This paten is of the usual shape. Its foot is a disk, attached by a round stem swelling out to the paten. Upon the foot is engraved: "*ANO DO 1568.*"*

SILVER CUP. Weight 9.7 oz. Height $7\frac{1}{2}$ in. Diam. of bowl $3\frac{3}{4}$ in.; of foot $3\frac{3}{8}$ in. Height of stem $3\frac{3}{8}$ in. Date **1845**.

London hall marks.

This is a perfectly plain cup, having a straight-sided bowl with a bell-shaped lip, a plain round stem swelling into the foot.

SILVER PATEN. Weight 7.5 oz. Diam. $7\frac{1}{2}$ in. Date **1845**.

London hall marks.

This paten is a plain round plate with a flat edge, and the middle part sunk.

SILVER PLATED FLAGON. Height $13\frac{3}{4}$ in. Diam. at top 4 in; at the foot $7\frac{3}{8}$ in.

Marks. 1. Leopard's head. 2. Fleur-de-lis, within a line of the same shape. 3. I.L., with a mark above.

This is a tall, straight-sided flagon, narrowing towards the top. It has an R shaped handle, and a round top to its lid, on which is a knob. It is made of copper, silver plated.

In 1845 the Rev. **Richard Cragg**, B.A., was incumbent of this parish; he served here as curate from 1796, and became rector in 1823, holding the living till his death on 27th Feb., 1849. It is highly probable that the modern silver cup and paten were provided by his bounty, assisted, perhaps, by the liberality of his nephew, **Edward Conder**, who in 1846 made a gift of church plate to Owston parish.

* For an illustration of this piece and notes on Elizabethan chalices, see *Church Plate*, by M. H. Bloxam, in *Associated Societies Reports*, Vol. viii., p. 365.

FRAMLAND. THIRD DEANERY.

AB KETTLEBY.
HOLWELL.
NETHER BROUGHTON.
BURROW.
LONG CLAWSON.
COLD OVERTON.

DALBY PARVA.
HARBY.
HOSE.
KIRBY BELLARS.
MELTON MOWBRAY.
BURTON LAZARS.

FREEBY.
SYSONBY.
WELBY.
SCALFORD.
SOMERBY.

 AB KETTLEBY.

SILVER CUP. Weight 6.2 oz. Height 6 in. Diam. of the bowl $3\frac{1}{4}$ in.; of the foot $2\frac{3}{4}$ in. Height of stem $2\frac{5}{8}$ in. Date 1719.

Hall marks. 1. Capital Roman D in a plain shield. 2. Britannia. 3. Lion's head erased. 4. Capital Roman L and small I, a pellet between, in a shaped stamp.

This cup has a straight-sided bowl rounded off below, with a bell-shaped lip. Its stem is thick, and divided in half by a plain round moulding, from whence it swells out to the bowl, and into a narrow foot ending in a round moulding and flat edge.

SILVER COVER PATEN with a foot. Weight 4.9 oz. Diam. $4\frac{7}{8}$ in. Diam. of foot $2\frac{1}{2}$ in. Height of foot $\frac{3}{4}$ in. Date 1634.

Hall marks. 1. Italic R in an oval shield. 2. Lion passant. 3. Leopard's head crowned, each being within an outer-shaped line. 4 R A., a quatrefoil below in an oval shield.

This paten clearly belonged originally to a cup of the same date, which from some cause or another was replaced by the present one in 1719. It has a flat edge $\frac{3}{4}$ of an inch wide, round the inside edge of which is a thick rim. The middle part is sunk in a shallow round. The foot is a disk attached to the paten by a stem swelling out considerably to both ends.

SILVER ELECTRO PLATED FLAGON. Height $9\frac{1}{2}$ in. Diam. at the top $2\frac{1}{4}$ in.; at the foot $3\frac{1}{2}$ in.

This is a plain jug-shaped flagon, its lid being surmounted by a double cross.

PEWTER FLAGON. Height 14 in. Diam. at the top $4\frac{1}{2}$ in.; at the foot $5\frac{3}{4}$ in.

No marks.

This is a very tall straight-sided flagon narrowing to the top. It has a narrow foot, a round top to its lid, surmounted by a round knob, and a tall purchase. Upon the lid is, in capital Roman letters, "*Ex dono Henrici Shepperson.*"

PEWTER PLATE. Diam. $8\frac{1}{2}$ in.

Marks. J. A., C. R., two maces below, within a circle.

This is a flat plate with a vertical edge. The upper surface is ornamented with sprays of conventional foliage cut in zigzag lines.

In the terrier for 1709 at Lincoln, all the notice that is made of the plate here is as follows: "there is one silver cup the value of it about 50s." Granting the cover paten was included in that notice, the cup of 1634, formerly here, weighed about 6 oz.

The silver plated flagon was the gift, at Easter, 1869, of the Rev. **John Fairbairn Johnson**, M.A., vicar of this parish from 1850 to 1880, and now of Bishopsdown Grange, Tunbridge Wells.

Of the donor of the pewter flagon I know nothing.

HOLWELL.

SILVER CUP AND COVER PATEN. Weight of cup 6.9 oz. Height $6\frac{3}{4}$ in. Diam. of the bowl $2\frac{3}{4}$ in.; of the foot 3 in. Height of stem $3\frac{3}{4}$ in. Date 1778. (PLATE 13.)

Hall marks. 1. Capital Roman M in a square shield shaped into a point. 2. Leopard's head crowned in a plain shield. 3. Lion passant in a plain oblong. 3. Three castles in an egg-shaped shield; the Newcastle mark. 4. I. L. above I. R., a gem-ring above the letters, in a plain oblong; *the mark of John Langland and J. Robertson.**

This cup has a straight-sided bowl rounded off below, having a raised lip. It has a narrow stem across which is a small cable moulding for a knob. The stem swells out a little towards its upper end, but it narrows below into a dome-shaped foot.

SILVER COVER PATEN. Weight 2.5 oz. Diam. $3\frac{1}{4}$ in. Height 2 in. Date 1778. (PLATE 13.)

This cover, stamped only with the lion passant and the Newcastle mark, has a flat edge, from which it rises up in a succession of round mouldings; its top being surmounted with a knob. Round its inside is a rim $\frac{1}{4}$ of an inch deep. It fits on to the cup both ways.

PEWTER PLATE. Diam. $8\frac{1}{2}$ in.

Mark. A seeded rose crowned between two leaves: an illegible name above.

NETHER BROUGHTON.

SILVER CUP. Weight 11.1 oz. Height $6\frac{1}{2}$ in. Diam. of the bowl $4\frac{1}{2}$ in.; of the foot $3\frac{1}{2}$ in. Height of stem $2\frac{1}{2}$ in. Date 1798.

London hall marks.

This cup has a deep hexagonal, egg-shaped bowl, and a round stem 1 in. thick in the middle, from whence it swells out towards the bowl and into a flat foot with an hexagonal edge. Upon one of the six sides of the bowl is the sacred monogram with a cross and three nails within a circle of glory; on the sides to the left and right of this is a candelabrum supporting seven lights. Upon the opposite side, is this coat of arms; surmounted by an earl's coronet: *Gyronny of three; 1. Per fesse Or and Argent, an eagle displayed with two heads Sable, on the*

* See *Church Plate in Dio. of Carlisle*, p. 185.

breast an escutcheon Gules charged with a bend vairé; Bouverie. 2. *Gules a bend vairé; De Bouverie, of Brabant.* 3. *Argent a bend gutté d'eau between two ravens Sable, a chief chequy Or and of the last; Pleydell: On an escutcheon of pretence over all, per chevron engrailed Gules and Argent, three talbots' heads erased counterchanged; Duncombe.* Upon the sides to the left and right of the arms is this inscription: "*Eucharistia Broughton inferioris in Ecclesia ευχαριστος agenda curam impendit Dominus manerii anno 1799.*"* The remaining portions of the bowl are ornamented with foliage, fruit, and musical instruments in relief.

SILVER PATEN with a foot. Weight 7.5 oz. Diam. $5\frac{1}{2}$ in. Diam. of the foot $3\frac{1}{2}$ in. Height of foot $1\frac{1}{8}$ in. Date 1798.

This paten has a flat hexagonal-shaped edge, the middle part being sunk flat. In the centre is the sacred monogram, round which is the same inscription as that on the cup. The foot is hexagonal.†

SILVER PLATED FLAGON. Height $9\frac{1}{2}$ in. Diam. at the top $\frac{3}{4}$ in.; at the foot 3 in.

This is a plain jug-shaped flagon.

In 1832 there was also here what Archdeacon **Bonney** describes as "an ancient silver cup, with a silver cover on the top:" against which he entered this: "Mem: I was asked whether it might be exchanged for a larger paten." At a later time the Archdeacon made also the following note in pencil: "Mr. **Scott** claims Lord **Radnor's** plate as his private property as rector of N. Broughton."

These two notes may be supplemented by the following tradition. A parishioner accused the Rev. **Thomas Scott**, whose incumbency began in 1831, of stealing the church plate, and undertook to prove the truth of his accusation at a meeting of the vestry. When all had assembled, and the charge had been publicly made, the plate, to the surprise of the meeting, was at once produced, which so confounded the accuser that he dropped down dead in the church. Whether this accusation would have proved a truthful one if it had been made a little later, cannot now be told for certain. Fortunately the modern cup and paten is still here; the ancient one, however, did not survive Mr. **Scott's** incumbency, which ended in 1847.

The modern silver cup and paten, were the gift of **Jacob Pleydell-Bouverie**, 2nd Earl of **Radnor**. This gentleman was the eldest son of **William**, 2nd Viscount **Folkestone** and 1st Earl of **Radnor**, by his first wife **Harriet**, only daughter of Sir **Mark-Stuart Pleydell**, Bart., of **Coleshill**, in **Berks.** and **Wilts.**, and was born on 4th March, 1750. Upon the death of his father in 1776, he succeeded to the **Bouverie** title and estates in **Wilts.** and **Kent**, and two years later inherited his maternal grandfather's property at **Coleshill**, adopting the name of **Pleydell**, in accordance with that relative's will. The Earl of **Radnor** married on 24th Jan., 1777, the Hon. **Anne**

* "For celebrating the eucharist of Nether Broughton 'decently' in the church, the lord of the manor made this provision in the year 1799."

† An illustration of this cup and paten is given in *Nichols*, Vol. iii., p. 257.

Duncombe, second daughter and co-heir of **Anthony**, Lord **Feversham**,* with whom he obtained a half share in the manors of Nether Broughton and Dalby-on-the-Wolds, which properties had been bought by his wife's great uncle, Sir **Charles Duncombe**, Knt. Upon a partition being made between the Earl of **Radnor** and his brother-in-law, **John Bowater**, Esq., in 1788, the estates in this parish were allotted to the former. The Earl was also the owner of a small estate in Asfordby, and of the principal part of the parish of Tilton, which latter had been brought into his family by **Mary**, daughter and heir of **Bartholomew Clarke**, first wife of his grandfather, **Jacob**, 1st Viscount **Folkestone**. The Earl of **Radnor** died on 27th Jan., 1828, and was buried in the mausoleum at Britford, Wilts, on 4th Feb. By his Countess, who died on 14th Oct., aged 70, in the year following, and was buried in the same place on the 23rd, he had four sons, the youngest of whom was the Hon. **Philip Pleydell Bouverie**, M.P., whose eldest son, **Philip Pleydell Bouverie**, Esq., of Bridgwater, Somerset, is the present possessor of the family estate in this parish.

The plated flagon was bought, and one of pewter sold, a few years ago.

BURROW.

SILVER CUP WITH COVER PATEN. Weight of cup 9.7 oz. Height $7\frac{3}{8}$ in. Diam. of the bowl $3\frac{3}{4}$ in.; of the foot $4\frac{3}{8}$ in. Height of stem $2\frac{3}{4}$ in. Date 1670.

Hall marks. 1 Capital old English N in a pointed shield. 2 Lion passant. 3 Leopard's head crowned; each of the two last having an outside line following their outline. 4 T K, a cinquefoil below, within a plain pointed shield.

In shape and construction this cup is the same as most others of this date. It has a deep straight-sided bowl with a bell-shaped lip and a flat base. It has a thick round stem without a knob, swelling out into a plain flat foot; under which the lion passant is repeated. Like others of this shape, this cup is of very simple construction, its bowl being beaten out of one piece of metal, its stem and foot out of another.

SILVER COVER PATEN with a foot. Weight 4.2 oz. Diam. $5\frac{1}{2}$ in. Diam. of the foot $2\frac{1}{4}$ in. Height of foot $\frac{5}{8}$ in. Date 1670.

Hall marks the same as those on the cup.

This paten has a flat edge $\frac{3}{4}$ of an inch wide, the middle part being sunk flat $\frac{1}{2}$ of an inch in depth. Its foot is a disk attached to the paten by a straight round stem. The lion passant is stamped on the foot.

SILVER CUP. Weight 8.2 oz. Height $6\frac{3}{8}$ in. Diam. of the bowl $3\frac{1}{4}$ in.; of the foot $2\frac{7}{8}$ in. Height of stem 3 in. Date 1869.

London hall marks.

This cup has an egg-shaped bowl, a thin round stem with a small knob and a plain

* For pedigree of Duncombe, see *Nichols*, Vol. iii, p. 255.

round foot. A beaded moulding runs round the little knob and also round the edge of the foot. Upon the bowl is the sacred monogram within a circle of glory. Underneath the foot is: "*In memoriam, Charles Frederick Peake, 1870.*"

SILVER FLAGON. Weight 20.3 oz. Height $10\frac{3}{8}$ in. Diam. at the top $2\frac{1}{4}$ in.; at the foot $3\frac{3}{8}$ in. Date 1862.

London hall marks.

This jug-shaped flagon has a short thick neck swelling into a deep middle, which rests on a small round foot. At the top attached to the neck is a small handle. In the middle in front is engraved the sacred monogram within a circle of glory. There is some engraved ornament round the upper and lower part of the middle. Beneath the foot is the same inscription as that on the last mentioned cup.

PEWTER FLAGON. Height $9\frac{1}{2}$ in. Diam. at the top $3\frac{1}{2}$ in.; at the foot $4\frac{5}{8}$ in.

Marks. 1 On the back of the handle "B," for Burrow. 2 Under the foot I S, four pellets above and four below, within a dotted circle.

This is a small straight-sided flagon narrowing a little to the top. It has a flat top to its lid with a round knob on it. The purchase is pierced in the shape of a heart.

PEWTER BASIN. Diam. $9\frac{1}{4}$ in. Depth $2\frac{1}{4}$ in.

No marks.

This is a plain basin with a projecting rim. Underneath is scratched: "*Burton Freeman, 1801, Clerk.*" This basin was formerly placed in the font: **Burton Freeman** was the name of the parish clerk at the end of the last century and beginning of this.

In a terrier at Lincoln, signed by **William Parker**, rector of Burrow from 1686-1723, the church plate here is mentioned thus; "A pewter flagon, a silver cup and cover cost £4 having no inscriptions."

In 1670 the lord of the manor and one of the principal landowners here was **Rowland Brown**, Esq., of Leesthorpe, high sheriff of the county in 1678, who died in 1712.

The modern silver cup and flagon were presented to this church by **Frederick Peake**, Esq., of Ashtead, Surrey, and 6, Bedford Row, London, and by his wife **Charlotte Mary**, who died on 19th March, 1888, aged 58; in memory of their second son, **Charles Frederick**, who died at the age of 16, in 1870, of a fever caught at Marlborough School, where he had gained prizes and shown promise of future distinction. **C. F. Peake** was buried in this churchyard, a small marble cross stands over his grave. **Mr. Frederick Peake** is the owner of an estate in this parish.

LONG CLAWSON.

SILVER PLATED CUP. Height $9\frac{1}{2}$ in. Diam. of the bowl 4 in.; of the foot $4\frac{1}{4}$ in. Height of stem $5\frac{1}{2}$ in.

This cup has a straight-sided bowl, a narrow stem, having a moulding below its middle for a knob, and a thick raised foot. Upon the bowl is engraved the sacred monogram with a cross and three nails within a circle of glory.

SILVER PLATED PATEN with a foot. Diam. $8\frac{1}{4}$ in. Diam. of the foot $3\frac{1}{2}$ in. Height of foot $1\frac{1}{2}$ in.

This is a plain paten with the sacred monogram in its centre.

SILVER PLATED DISH. Diam. 9 in.

SILVER PLATED FLAGON. Height $12\frac{1}{4}$ in. Diam. at the top $3\frac{3}{4}$ in.; at the foot $6\frac{1}{2}$ in.

This is a straight-sided flagon narrowing towards the top. On one side is the sacred monogram and on the other is this inscription: "*This communion service was presented to the parish church of Long Clawson by Thomas Mitchell, Esq., Patron: the Rev. Tho. Mitchell, M.A., Vicar, 1848.*"

The donor of this service of communion plate, which together with the box cost £15, was the father of the late vicar and a member of the corporation of the city of London. He died in the year 1855, at the age of 83. An ancient silver cup, which belonged to this church up till the time this new set was given, was then sold, the money being given to the poor of the parish.

COLD OVERTON.

SILVER CUP. Weight 12.7 oz. Height $8\frac{1}{2}$ in. Diam. of bowl and of foot $3\frac{7}{8}$ in. Height of stem $3\frac{3}{4}$ in. Date 1738.

Hall marks. 1. Capital Roman C in a square shield. 2. Leopard's head crowned in a plain shield. 3. Lion passant in a plain oblong. 4. I. W. in a shaped oblong. *Mark of John White.*

This cup has a straight-sided bowl with a raised lip, and a round stem, with a small moulding for a knob. The stem swells out into the bowl and the foot, the latter being finished off with round mouldings. Upon one side of the bowl is the sacred monogram with a cross and three nails within a circle of glory; and on the opposite side is this inscription: "*Dei Gloria et Servitio Altaris Sui In Parochiali Ecclesia de Coldoverton In comitat Leicestrens me dicabat Johannes Turner Arm Anno Domini 1738.*"*

SILVER PATEN with a foot. Weight 7.2 oz. Diam. $5\frac{3}{8}$ in. Diam. of foot $2\frac{3}{4}$ in. Height of foot $1\frac{1}{2}$ in. Date 1738.

Hall marks as on cup.

This is a flat paten with a raised edge. Its foot is a disk, attached by a stem swelling out at both ends. Upon the foot is engraved the sacred monogram as on the cup; the same inscription being in the middle of the paten.

SILVER FLAGON. Weight 27.9 oz. Height $10\frac{1}{4}$ in. Diam. at the top $3\frac{3}{8}$ in.; at the foot $5\frac{3}{4}$ in. Date 1738.

Hall marks as on cup.

This is a straight-sided flagon, narrowing to the top, with a round top to its lid. In front is the sacred monogram, below which is the same inscription as that on the cup.

* "To the Glory of God and for the use of His Altar in the Parish Church of Cold Overton, in the County of Leicester, John Turner, Esq., dedicated me in the year of our Lord 1738."

SILVER PLATE. Weight 12.9 oz. Diam. 8 $\frac{3}{8}$ in. Date 1738.

Hall marks as on cup.

This is a plain plate with the sacred monogram in its centre. On the back is the same inscription.

From the terrier of 1709 we learn that there was then here; "A silver cup with a cover about 6 oz.: one pewter flagon and one pewter plate." None of these pieces were here in 1832.

John Turner descended from the **Turners** of Atherstone-upon-Stour, was the only son of **Henry Turner**, Esq., of this parish, sergeant-at-law, by his wife **Mary**, only daughter of **Thomas Frewen**, Esq., of Brickwall, M.P. for Rye, and was born on 27th July, 1691. Upon the death of his father in 1724, he inherited the Cold Overton and Sapcote estates, a mortgage on which by their former owner Mr. **St. John**, had been effected with Mr. **Turner's** grandmother, **Martha Turner**, whose marriage portion had been so invested. Mr. **John Turner** married at Cold Overton on 15th Aug., 1727,* his first cousin, **Selina**, youngest daughter of Sir **Edward Frewen**, Knt., by **Selina**, daughter of **John Godschall**, of East Sheen. He was high sheriff of the county in 1739. He died without issue on 5th Aug., 1753, and was buried in Cold Overton church. Mrs. **Turner** survived her husband until 5th March, 1770.

Near to their graves is a large slab against the North wall of the North aisle on which together with a short inscription† are these arms within a circle; *Ermine on a cross Sable five millrinds Argent*; **Turner**; *impaling, Ermine four bars Azure, a demi lion rampant issuant Gules*; **Frewen**. Mr. **Turner** dying without issue his estates in this parish and Sapcote, passed after the death of his widow to his cousin, and his wife's cousin, Mr. **Laton Frewen**, of Brafferton, co. York, who took the name of **Turner**. Upon the death of which gentleman without issue in 1777, these estates came into the possession of his first cousin, the Rev. **Thomas Frewen**, rector of Sapcote, the great-grandfather of their present owner, **Edward Frewen**, Esq., of Brickwall, Northiam, Sussex.

DALBY PARVA.

SILVER CUP. Weight 5.2 oz. Height 5 $\frac{1}{8}$ in. Diam. of bowl 3 $\frac{1}{2}$ in.; of foot 2 $\frac{3}{8}$ in. Height of stem 2 $\frac{3}{8}$ in. Date 1567.

Hall marks. 1. Small black letter K, with annulet below, in a plain shield. 2. Lion passant. 3. Leopard's head crowned, each with a line outside. 4. Illegible.

This little cup has a bowl shaped into an inverted truncated cone, with a flat base. Its stem is evenly-balanced, being divided in half by a round moulding on a fillet. The stem swells out towards each end, finishing in a vertical edge, round which is the reed ornament. The foot ends in a round moulding and flat edge. This cup has been much repaired. At an inch from the lip a join has been made all round the bowl, to hide and strengthen which a small moulding has been placed upon it all round. The whole of the foot is new. The bowl shows signs of having originally been gilt inside.

* Parish Register.

† For which, see *Nichols*, Vol. ii., p. 141.

SILVER PATEN. Weight 4.7 oz. Diam. $6\frac{3}{4}$ in. Date 1851.

London hall marks.

This plain paten has in its centre the sacred monogram within a double triangle.

SILVER FLAGON. Weight 13.2 oz. Height $9\frac{1}{2}$ in. Diam. at the top $1\frac{3}{8}$ in.; at the foot $3\frac{1}{2}$ in. Date 1851.

London hall marks.

This is a jug-shaped flagon with an ornamental handle. Round the middle is; "*Gloria in excelsis Deo alleluia.*"

In 1832 there was here, in addition to the silver cup, a pewter flagon and basin, with two pewter plates.

The modern silver paten and flagon were the gift of the late **Edward Bouchier Hartopp**, Esq., of Dalby House, J.P. and D.L., who also defrayed the cost of the repairs effected upon the ancient cup. This gentleman was the representative of a junior branch of the **Hartopps**, of Burton Lazars, being the direct descendant of **George**, the second surviving son of **William Hartopp**, who owned land in this parish 300 years ago, which passed to his son **George**; his eldest son **Edward** was created a baronet, and was the ancestor of the senior line of this ancient Leicestershire family. **George Hartopp's** direct representative, **Mr. E. B. Hartopp**, was the eldest son of **Edward Hartopp**, Esq., of Little Dalby, by his wife **Anna Eleanora**, eldest daughter of **Sir Bouchier Wray**, Bart., and was born on 14th Dec., 1809. This gentleman succeeded early to the family estates in this parish, Burton Lazars, and Scraftoft, which were admirably managed by him during his long ownership, all living on his estates being treated by their landlord with great kindness and liberality. **Mr. Hartopp** was high sheriff of the county in 1832, and once M.P. for North Leicestershire. He married first, at Naples, on 18th Feb., 1834, **Honoria**, second daughter of Major-Gen. **William Gent**, who died in 1850, and by whom he had two sons and several daughters; secondly, **Miss Marie Hey**, of Hamburg, who survives her husband. **Mr. Hartopp** died at his house in Thurloe Square, London, on 31st Dec., 1884, and was buried in Little Dalby church in the North transept, on the wall of which is an oblong brass to his memory, bearing a short inscription ending with the text: "*He that believeth on me hath everlasting life.*" A painted window has also been placed in this church to his memory by his widow.

Mr. Hartopp made this gift of communion plate at the time when he took the principal share in rebuilding Little Dalby church in 1852. His uncle the Rev. **Samuel Hartopp**, for many years vicar of this parish, helped on the work by bequeathing £1000 towards the expense of rebuilding the tower. Both **Mr. Hartopp's** sons died before their father; the eldest only having married. This gentleman, **Capt. William Wrey Hartopp**, left by his wife, **Lina**, second daughter of **Thomas Howe**, Esq., two daughters, the eldest of whom, is now the sole owner of the family estates in Dalby Parva, Burton Lazars, and Scraftoft, as well as those in Kerry and Limerick.

HARBY.

SILVER CUP AND COVER PATEN. Weight of cup 7.5 oz. Height $7\frac{1}{2}$ in.; Diam. of bowl 4 in.; of foot $3\frac{1}{2}$ in. Height of stem $3\frac{3}{8}$ in. Date *circa* 1600.

No marks.

This cup has a nearly straight-sided bowl with a bell-shaped lip, a straight stem swelling a little at each end into a vertical edge, and a foot of the usual Elizabethan shape. The dints in this cup have been beaten out and the bowl repaired at the base. To all appearance there was formerly a knob on the stem which was possibly taken off when the cup was repaired.

SILVER COVER PATEN. Weight 3.6 oz. Diam. 4 in.

No marks.

This cover has a flat edge from whence the main part is sunk into a shallow round. The rim has been taken off, and the whole of the outer part seems to have been replaced with new metal. Upon the top has been replaced the remains of a portion of the old foot upon which is a round knob of modern make. At the time when this old cup and cover were repaired there was engraved on the former the sacred monogram with a cross within a circle of glory; and "*Harby Church*," which was also placed on the cover.

SILVER FLAGON. Weight 23.1 oz. Height $6\frac{3}{4}$ in. Diam. at the top $3\frac{3}{4}$ in.; at foot $4\frac{5}{8}$ in. Date 1773.

Hall marks. 1. Capital Roman G in a square ogee shield. 2. Three castles in pointed oval shield. 3. Leopard's head crowned in a plain pointed shield. 4. Lion passant in shaped oblong. 5. I I, script letters in plain oblong.

This a pretty little tankard of Newcastle make, originally a secular piece of plate in all probability. It has a straight drum narrowing towards the top. Both the lid and the foot have gadrooned edges. Underneath the foot is this inscription; "1773. *St. Mary's, Harby, 1873. M. O. Norman, Rector.*" "*Till He come.*"

SILVER PLATED DISH with a foot. Diam. $7\frac{1}{8}$ in. Diam. of the foot $3\frac{3}{8}$ in. Height of foot $3\frac{3}{8}$ in.

This is quite a plain dish having in its centre the sacred monogram with a cross and three nails within a circle of glory. On the back is "*Harby Church. The gift of W. E. Hartopp, Rector. 1842.*"

In 1832, there was here in addition to the cup and cover, a small pewter flagon inscribed "I.H. 1726," also a plate and basin of pewter. The flagon was stolen out of the church about ten years ago. The two other pieces have not been in existence in recent years.

The donor of the plated dish the Rev. **William Evans Hartopp**, was the second son of **Edward Hartopp Wigley**, Esq., of Little Dalby, by the Hon. **Juliana Evans**, daughter of **George**, 3rd Lord **Carbery**, and was born in 1793. He proceeded to the degree of B.A. from Trinity College, Cambridge, in 1817, and M.A. in 1831. Mr. **Hartopp** was rector of this parish from 1826, till the day of his death, 2nd Oct., 1852. He married **Eliza Georgiana**, daughter of **George Stamer Gubbins**, Esq., of Kilrush, co.

Limerick, by whom he had an only child, **Edward Samuel Evans Hartopp**. Mr. **Hartopp** was buried at Little Dalby.

The silver flagon was presented by the present rector of the parish the Rev. **Manners Octavius Norman**, B.A., who has also contributed largely towards the restoration of the church.

HOSE.

(a)

SILVER CUP. Weight 8.5 oz. Height $8\frac{5}{8}$ in. Diam. of the bowl and of the foot $3\frac{1}{4}$ in. Height of stem $4\frac{1}{2}$ in. Date 1847.

Sheffield hall marks.

This cup has a straight-sided fluted bowl and a narrow fluted stem swelling out to both ends, having a small knob. Upon the bowl is the sacred monogram and a cross within a circle of glory. Round the foot is "*Presented to Hose Church, Leicestershire, by Thos. Dickinson Hall, Esq^{re}. 1849.*"

SILVER PATEN. Weight 7.5 oz. Diam. $8\frac{1}{3}$ in. Date 1847.

Sheffield hall marks.

This is a pentagonal-shaped paten with a trefoil at each angle. In the centre is the sacred monogram with a cross in a circle of glory. Underneath is the same inscription as that on the cup.

(b)

PWTER FLAGON. Height $9\frac{1}{8}$ in. Diam. at the top $3\frac{7}{8}$ in.; at the foot $5\frac{1}{2}$ in. (PLATE 9.)

Marks. 1. On the lid, an acorn between two guttée in a shaped stamp, repeated four times. 2. Inside, on the bottom, is possibly T. C. in a circle.

This is a straight-sided flagon narrowing towards the top, having a flat top to its lid and a wide foot. In front is this coat of arms: *two bars engrailed impaling blank*. Above the arms is: "*1670 T. R.:*" and below is: "*The gift of Thomas Rowse to hose Church.*"

PWTER PLATE. Diam. $9\frac{5}{8}$ in.

Marks. On edge. 1. H. D. 2. In four small shapes, (a) R. E. (b) Leopard's face. (c) A buckle. (d) Lion passant. 3. On the back, a windmill between R. E., in a circle. 4. Rose crowned.

PWTER BASIN. Diam. $9\frac{1}{8}$ in. Depth $1\frac{1}{4}$ in.

Marks. 1. Eagle displayed, "Thomas" above, "Hodgkin" below, in a circle. 2. X crowned. 3. "London," in a shaped oblong.

This is a plain-shaped basin with a flat edge.

PWTER BASIN. Diam. $9\frac{1}{8}$ in. Depth $2\frac{1}{2}$ in.

Marks. 1. Seeded rose crowned between two sprays of foliage, repeated twice. 2. "London," on a scroll.

This is also a plain basin with a narrow flat edge.

There was formerly here "an ancient silver cup with a long thin stem or

stand," as described by Archdeacon **Bonney**. This was parted with when the new one was given, being melted down, as it is believed, and used in the manufacture of the new.

(a)

The donor of the two modern pieces was the only son of **William Henry Hall**, Esq., by **Harriet**, eldest daughter of **William Dickinson**, Esq., of Muskham Grange, Notts., and was born 18th Aug., 1808. Mr. **Thomas Dickinson Hall**, in 1835, inherited from his grandfather, **Thomas Hall**, Esq., of Nottingham, estates in this parish of Hose, and also in Broughton and Whatton in the Vale, co. Notts., being lord of the manor of the latter and patron of the church. He was a J.P. for the Belvoir division of Leicestershire, and a J.P. and D.L. for Nottinghamshire, serving the office of high sheriff for the latter county in 1843. Mr. **Hall** was a liberal benefactor to the church; one of his earliest works was the rebuilding of the chancel of Whatton church, a few years after he inherited his estates; the same church was, many years later, in 1873, thoroughly restored by him at a cost of £2000: amongst his other benefactions was the erection of a chapel of ease in Barnstone, co. Notts., at a cost of £600, and a donation of £2000 towards the endowment of the new district church of Scarrington, in the same county. He died upon 2nd May, 1879, and was buried in Whatton churchyard, where there is over his grave a recumbent monument on the top of which is a floriated cross and a short inscription, this text running round the edge; "*Having a desire to depart and be with Christ, which is far better.*" Mr. **Hall** married, at Langford, co. Notts., on 12th May, 1840, **Sophia Elizabeth**, daughter of **James Haffenden**, Esq., of Homewood, Kent, by **Catherine**, his wife, by which lady, who survives him, he had several sons and daughters, the second son being the Rev. **F. D. Hall**,* and the fourth the Rev. **Thomas K. Hall**, the owner of his father's property in Hose.

(b)

Thomas Rowse, the donor of the pewter flagon, came of a family which has been long settled in this part of Leicestershire: different members of which were freeholders in Bottesford, Stathern, and this parish. The registers of Hose record the burial of **Thomas Rowse** on 4th April, 1719, and of his wife **Elizabeth** on 23rd Feb., 1734. Several of their children were baptized here late in the 17th century, and early in the 18th.

KIRBY BELLARS.

SILVER CUP. Weight 10.1 oz. Height 6 $\frac{5}{8}$ in. Diam. of the bowl 4 $\frac{1}{8}$ in.; of the foot 4 in. Height of stem 2 $\frac{3}{4}$ in. Date 1638. (PLATE 8.)

* *Vide* Owston.

Hall marks. 1. Court hand A in a plain shield. 2. Lion passant. 3. Leopard's head crowned, each within an outer-shaped line. 4. G.S., a pellet above each letter and a crosier between them, within a plain shield.

This cup has a straight-sided concave bowl, rounded into a flat base. Its thick stem has near the top a disk, from whence it swells out into the foot, which is rounded off into a curved edge. The disk is really a flat ring slipped over the end of the stem, which, with the foot, is all of one piece: the bowl being also beaten out of one piece of metal.

SILVER PATEN with a foot. Weight 4.6 oz. Diam. $4\frac{7}{8}$ in. Diam. of the foot $2\frac{1}{2}$ in. Height of foot $\frac{7}{8}$ in. Date 1638. (PLATE 8.)

Hall marks as on the cup.

This paten fits on the cup with the foot downwards. It has a flat edge from whence the middle part is sunk flat. The foot is a disk attached to the paten by a stem swelling out at both ends.

SILVER DISH with a foot. Weight 9.5 oz. Diam. 8 in. Diam. of the foot $3\frac{1}{4}$ in. Height of foot $1\frac{7}{8}$ in. Date 1705.

Hall marks. 1. Court hand K in a plain shield. 2. Britannia. 3. Lion's head erased. 4. Capital Roman R and small O, three pellets above and below, within an oval. Mark of *Philip Rollos*.

This is a flat dish with a gadrooned edge, standing on a hollow foot with a similar edge. Underneath is "*March 4, 1705:*" and in the centre within an oval shield is this coat of arms; *Gules a bend Or, in the sinister chief a cinquefoil Argent*. Crest: *On a mount Vert a griffin sejant Or, holding in the dexter foot an eastern crown Argent*; *De la Fontaine*. (FIG. 18.)



Fig. 18.

PEWTER FLAGON. Height $13\frac{1}{4}$ in. Diam. at the top $4\frac{1}{4}$ in.; at the foot $6\frac{3}{8}$ in.

No marks.

This is a tall straight-sided flagon narrowing a little towards the top. Its lid has a round top surmounted with a knob. The purchase is a large one, and is pierced in the shape of a heart above a diamond.

In 1638, the principal landowner here was **Sir Erasmus De la Fontaine**, Knt., who early in the reign of **James I.** purchased a property here and in **Stonesby**, from **Edward Shelden**, Esq., and others. He also owned estates in the counties of **Bedford** and **Essex**. He was knighted at **Greenwich**, on 15th June, 1623.

The arms on the silver dish show the donor of it to have been **John De la Fontaine**, Esq., who was the only son of the above **Sir Erasmus De la Fontaine**, by his wife, **Mary**, second daughter of **Edward Noel**, 2nd Viscount **Campden**. Upon the death of his father on 15th March, 1672, Mr. **De la Fontaine** inherited the principal share of his estates in **Kirby Bellars** and **Stonesby**, together with a large mansion-house on the former property, standing on the site of the Priory. This house which had been almost entirely burnt down by the Parliamentarians in 1644, had been rebuilt by **Sir Erasmus**.

The only portion remaining at the present day, is the picturesque block of stabling with a gateway in the centre, over which, within a square stone frame, are the arms and crest of this family, similar to those already described. The donor of this dish married, first in 1663, **Frances**, the youngest daughter of Sir **Geoffrey Palmer**, 1st Bart., of East Carlton, co. Northants, and widow of **Henry Harpur**, Esq., of Swarkston, co. Derby; secondly, **Elizabeth**, whose maiden name I take to have been **Needham**, and who died on 6th Dec., 1729, aged 72, and was buried in the South transept of Melton church.* Mr. **John De la Fontaine**, who had no issue by either wife, died on 8th May, 1708.

A considerable portion of his estates passed to his fourth sister, **Anne**, wife of Sir **Thomas Meres**, Knt., in accordance with the will of their father, Sir **Erasmus De la Fontaine**. In his will dated 17th Jan. 1706, and proved P.C.C. May, 1708, **John De la Fontaine** left considerable sums to charitable objects, viz., £2000 to Chelsea Hospital; £2000 to Greenwich Hospital; £1000 towards the rebuilding of St. Paul's Cathedral; £20 to the poor of this parish, and the same sum to the poor of Stonesby. His bequest to this parish was apparently spent and not invested, as it does not now exist. The bulk of his estate he bequeathed to his cousin, **Andrew Noel**, Esq., of Scraftoft, and to his nephew **Nicholas Tyrwhitt**.†

MELTON MOWBRAY.

(a)

SILVER GILT CUP. Weight 25.2 oz. Height $8\frac{1}{4}$ in. Diam. of the bowl $4\frac{3}{4}$ in.; of the foot $4\frac{7}{8}$ in. Height of the stem $4\frac{3}{4}$ in. Date **1559**. (PLATE 12.)

Hall marks. 1. Small black letter B, within an outside line following its outline. 2. Lion passant. 3. Leopard's head crowned; each of the two latter having an outside line. 4. A stag's head, within a shaped shield.

This is a very handsome cup, and is exceptionally strongly made. Though it is the oldest Elizabethan piece in this county, it at first sight might seem to belong to a much later date, for it is in shape dissimilar in many ways to the usual Elizabethan cup. It has a short bowl, an inverted truncated cone in shape, with a flat base. Instead of a knob the stem has, near the top, a disk across it, from whence it swells out very slightly into a foot of the usual Elizabethan shape. For ornament, the egg and tongue moulding runs round the bottom of the bowl and the flat edge of the foot, while bands of lattice-work filled with tracery run round both ends of the stem, and round the vertical edge of the foot. On one side of the bowl is "*Calix Benedictionis*;" and on the other "*The gift of Robert Hudson Haberdasher of London, October, 1627.*" To all appearance this was always a communion cup, and so must have formerly belonged to some other church.

(b)

SILVER CUP. Weight 11.4 oz. Height $7\frac{3}{8}$ in. Diam. of the bowl $4\frac{1}{8}$ in.; of the foot 4 in. Height of the stem $3\frac{5}{8}$ in. Date **1630**. (PLATE 12.)

* *Nichols*, Vol. ii., p. 254.

† For extracts from will, *ibid.*, p. 362.

Hall marks. 1. Italic N in a pointed shield. 2. Lion passant. 3. Leopard's head crowned, each of the two latter having an outside line. 4. An escallop within a shield of the same shape.

This cup, in shape, may be called a plain copy of the former one. Upon one side of the bowl is "*Calix Benedictionis*:" upon the opposite side is "*Melton Mowbray, 1631.*" The lion passant is repeated under the foot.

(c)

SILVER GILT PATEN with a foot. Weight 8.2 oz. Diam. $7\frac{1}{4}$ in. Diam. of the foot $3\frac{1}{8}$ in. Height of foot $1\frac{3}{8}$ in. Date 1694. (PLATE 12.)

Hall marks. 1. Small black letter R, in a pointed shield. 2. Lion passant, in a plain oblong. 3. Leopard's head crowned, in plain shield. 4. T. T., a zigzag line between the letters and a quatrefoil below, within a shaped shield.

This paten is flat in shape, with a gadrooned edge. The foot is a hollow drum, swelling out towards the lower end, which is also gadrooned. In the centre of the paten is the sacred monogram, with a cross rising out of the middle letter, within a circle of glory. Below the monogram is: "*Escā de celo.*"* Underneath the paten is: "*Deo et Ecclesie. Ex dono S. Henley, A.M., Ecclesie Parochialis de Melton Mowbray Vicarii 1695;*" opposite to this is: "*Τά ΣΑ Εκ Τῶν Σῶν.*"† The lion passant is repeated under the foot.

(d)

SILVER FLAGON. Weight 37.1 oz. Height $10\frac{3}{4}$ in. Diam. of the top $4\frac{1}{8}$ in.; of the foot $6\frac{1}{4}$ in. Date 1638.

Hall marks. 1. Court hand A, in a pointed shield. 2. Leopard's head crowned. 3. Lion passant, each of the two latter having an outside line following its outline. 4. P. I., a heart below, within a shaped shield; the second letter is indistinct.

This is a straight-sided flagon, narrowing towards the top. The lid is flat on the top, and rounded off into a flat projecting edge. The handle is of the usual shape. In front of the flagon, within a laurel wreath, are these arms: *Sable a chevron between three otters passant Argent, a crescent for a difference; Hartopp.* (PLATE 12.) Below the arms is: "*The gift of Samuell Hartopp.*"

(e)

SILVER FLAGON. Weight 47.7 oz. Height 11 in. Diam. at the top $4\frac{1}{4}$ in.; at the foot 7 in. Date 1729.

Hall marks. 1. Capital Roman O in a pointed shield. 2. Leopard's head crowned in a plain pointed shield. 3. Lion passant in a plain oblong. 4. On the back of the handle A B, a horse shoe above the letters and a mullet of six points below, within a shaped shield. Mark of *Abraham Butoux.*

This is also a straight-sided flagon, narrowing towards the top. Its later make is shown by its having a raised rounded top to its lid. On the drum in front is the sacred monogram with a cross above and three nails below within a circle of glory. Below this is "*The gift of Mary Greene, 1730.*" Beneath the inscription are these arms within a lozenge; *Vert, three stags trippant Or in chief two sinister hands Gules; Greene: impaling; Sable, a chevron Gules between three bugle horns Or; Waite.* The lozenge bearing these arms is set within some very beautiful engraving. The maker's mark is repeated beneath the foot of this flagon.

* "Food from heaven." † "To God and the church. The gift of S. Henley, M.A., vicar of the parish church of Melton Mowbray, 1696." "Thine of thine own," see LXX. 1 Chron. xxix. 14. The engraver should have put "Τά."

SILVER ALMS DISH. Weight 26 oz. Diam. 12 $\frac{1}{8}$ in. Date 1734.
(PLATE 12.)

Hall marks. 1. Capital Roman T in a pointed shield. 2. Leopard's head crowned in a plain pointed shield. 3. Lion passant in a plain oblong. 4. G. S., a circular object below, within a shaped shield. Mark of *Gabriel Sleath*.

This perfectly plain alms dish has in its centre within a lozenge the same arms as those on the last-mentioned flagon, being also surrounded by a beautifully engraved design. Above the arms is "*The gift of Mrs. Mary Green, 1734.*"*

SILVER PLATED DISH. Length 12 $\frac{3}{4}$ in. Width 10 $\frac{1}{4}$ in.

This is a long-shaped salver, rounded at the ends, with four round feet underneath.

PEWTER BASIN. Diam. 14 in. Depth 2 $\frac{1}{4}$ in.

No marks.

This is a plain basin-shaped dish, having on its edge: "*Tho. Crane, Jno. Brewen, Churchwardens. 1721.*"

PEWTER ALMS DISH. Diam. 12 in.

Marks. Underneath. 1. Anchor crowned between "16" and possibly "75," a spray of foliage on either side, "*Tho. King*" above. 2. Rose crowned. 3. On edge in four small shapes; (*a*) Anchor. (*b*) Crown. (*c*) Star of six points. (*d*) T. K., cinquefoil below, rose above. Round the edge of this dish in rather rude Roman capitals is "*He that hath pitie upon the poor lendeth to the Lord. Pro: ye 19th Ver ye 17th.*"

TWO PEWTER DISHES. Diam. of each 12 in.

Marks. Underneath. 1. Out of a ducal crown a horses jamb, within an ornamental shape. 2. X crowned. 3. London. 4. In four small shapes; (*a*) Per chevron engrailed, three talbots' heads erased. (*b*) On a fesse three escallops. (*c*) Griffin's head erased. (*d*) I. L. On the edge of each is "*Jno. Darmen, Will. Underwood, Churchwardens. Melton. 1792.*"

PEWTER PLATE. Diam. 9 in.

Marks. 1. Out of ducal crown an eagle rising towards sun in splendour, in an ornamental shape. 2. X crowned. 3. London. 4. In four small shapes; (*a*) Per chevron engrailed, three eagles' heads erased. (*b*) Eagle's head on a wreath. (*c*) Sun in splendour. (*d*) B. and V.

About thirty years ago the churchwardens' accounts for this parish, ranging, with some gaps from 1547 to the end of the 16th century, were found in an old box in a cellar;† with them is an inventory of some of the church goods, made during the episcopate of **John Longland**, 1521-1547, and probably drawn up for the commissioners sent in the 37th year of **Henry VIII.** to survey the chantries and guilds of this country. In that inventory these pieces of church plate are thus mentioned;

"Sylver Juells of the Churchys.

"Itm^a a crosse of Selvyr and parsell geltt ij crewetts of selver psell gelt.

"Itm. ij paxes of selver psell geltt and a shyp of clene selver.

"Itm. a grett chalys gelt a grett pyx & ij sensys of sellver.

"Itm. remayning in the church a Cresmatary of selvyr & a Hooselyng Coppe selver & gelt a pexe on the hye auter."

* The engraver has not given this lady the e at the end of her name on this dish. † Printed by T. North, F.S.A., in *Transac. of Leicest. Archi. Soc.*, Vol. iii., p. 180.

Most of these pieces, and some others not there mentioned, were sold early in the next reign, as the following entries in the accounts show;

"Anno 1547 or 1548.		
"Itm. rec ^d of W ^m Adcock for y ^e rest of a chalisse sold by hym		vjs. viiij <i>d</i> .
"Itm. rec ^d ffor a pere silv ^r sensers & a pax weyng xxxiiij oz. & d. & d. a quart ^r at iiijs. viiij <i>d</i> . y ^e oun ^r Sm ^r ...	vij <i>li</i> . xvjs. xid.	
"Itm. rec ^d ffor a pix Sylv ^r & Gilt Sold att London	vi <i>li</i> . ix <i>s</i> . iiiij <i>d</i> .	
"Itm. ffor a pere Sensers Sylv ^r a ship ffor frankynsense of sylv ^r & ij cruytts of Sylv ^r psell gilt	xv <i>li</i> . xiiijs. ix <i>d</i> .	
"Itm. rec ^d ffor the crosse of silv ^r & gilt sold at london	xix <i>li</i> . xs. vj <i>d</i> .	
"Itm. ffor ij Images Mary & John a pix Sylv ^r & Gilt	lvjs. x <i>d</i> .	
"Itm. ffor a cheyn Silv ^r & psell gilt.....	iiijs."	

In Queen **Mary's** reign some of those articles thus sold were replaced by others, made probably of inferior metal; these were in existence in 1562, when a list of vestments, books, etc., was entered at the end of the accounts, in which are these items;

- "A Crosse, a Lampe, a payre of senes and a shipp."
 "Itm. dd them more a Coote armo^r of sylke, a Challys."

Most of the vestments were sold in 1565; the accounts of which year are endorsed thus;

- "Ornaments off y^e Church.
 "M^d y^t whe delever up to y^e towne wth thys ou^r Account one chall^r psyll gylt w^{owt} patterne one coot Armoure of sylk ij Rede capps."

That "one chall^r" was parted with in 1568-9, as is told by this partly worn out entry;

- "P^d for y^e exchaunge off y^e communion cupe"

The cup thus obtained was the sole piece of plate here in 1594-5, at the end of which year's accounts is another list of church goods, this being the first entry;

- "Itm. one sylver cupe with a cever."

This cup and cover had been parted with at any rate before 1718.

In the parish chest are two terriers dated 1718 and 1724, a copy of the latter being at Lincoln. Both mention the four oldest pieces of silver communion plate now here; "the pewter alm's dish and also a large pewter flagon holding about 3 quarts," and "a large pewter bason for the font." In both terriers mention is also made of "an ancient crucifix," "a wand for penance," and a large press to hold vestments formerly belonging to the chantry. The two former articles do not now exist. Several panels, bearing the folded linen pattern, were saved at the destruction of the press in recent years and put into the doors of the cupboards now in use in the vestry.

(a)

Robert Hudson, the donor of the silver gilt cup, though not of gentle blood, sprang from a family of some repute in Melton. One member of it,

Thomas Hudson, was a spinney-warden in 1547 and in 1549 one of the feoffees of the Grammar School property.* Many members of the family appear in the earlier entries of the Parish Register, which begins in 1546. **Robert Hudson** was the son of **Thomas Hudson**, and was baptized at Melton on the 15th Jan., 1569-70,† his mother being, according to *Nichols*, **Anne** the daughter of **Hugh Spenser** of Melton.‡ He was a cotemporary of **Sir W. Herrick**, and, like him, settled early in life in London, developed into a wealthy citizen, yet loved to the last his native town. As a haberdasher **Robert Hudson's** affairs prospered so well that he was able to acquire the manor of Melton,§ which was sold, however, by his son; his name has been handed down in his native town in a more lasting way by the alms-houses that he built and endowed for the benefit of six poor aged men. **Robert Hudson** died at Chiswick, on 11th Sep. 1641, and was buried at Melton in the same month.|| He seems to have been married three times: his first wife was **Ann**, daughter of — **Barrett**, of London, near Whittington College, merchant,¶ by whom he had no children; his second was **Jane**, daughter of **Thomas Bilton**, of London, by whom he had a son, **Thomas**, baptized at St. Mary Bothaw, on 1st May, 1604,** and other children: **Jane Hudson** was buried in that church on 13th March, 1633-4,†† after which **Robert Hudson**, as we gather from his will, married thirdly the widow of — **Cotton**, and daughter of **Mr. Walker** of Chiswick.

In his will, dated 1st Aug., 1638, and proved, with a codicil dated 29th June, 1641, P.C.C., on 20th Sep., 1641, **Robert Hudson**, "of St. Mary Bothaw, Esq^r," desired to be buried with "first wife" in church of St. Mary Bothaw; §§ and left; to his wife £1500 in accordance with marriage covenant; to her his hatband set with diamonds, a gold chain and hatband of pearle; also certain specified rooms in his house in Candleweek Street, for three years after his death, if she so long remains a widow; to Sir **Gervaise Elwes**, Knt., **George Abbot**, **Jeremie Elwes**, and **William Sherman**, Esq^r., for the use of granddaughter **Anne Brigham**, £80; to "my son" **Vynor** and his wife £5 each; to sister **Elizabeth Hubbert** £5, to her son **Roger Hubbert** £1, and her son **Hugh Hubbert** £10; to cousins **Anne Stilles** and **Jane Wyatt** £2 each; to brother **Longfoote** £3; to godson **Robert Longfoote** £3; to cousins **Thomas** and **William Measures** all their debts; to wife of former £3, and to wife of latter £2; to cousin **Thomas**, "son of my brother," **Henry Hudson**, deceased, £50; to brother **Humble** and his wife 50s. each; to cousin **Andrew Bilton** and his wife £1 each; to cousin **William Spenser**, widower, and his son **William Spenser** £2 each; to Co. of Haberdashers £25 for a dinner after his death, also a bowl and cover of silver gilt costing £20; to parson of St. Mary, Bothaw, £5 for a sermon on "Tuesday next after Twelfth day in Christmas after my death being my birthday;" to daughter, the wife of son **Henry Hudson**, £100; to grandchild **Henry Hudson** £1000 when 21; to **Edward Cotton** "my

* *Trans. of Leic. Archae. Soc.*, Vol. i., p. 255. Vol. iv., p. 331.

† Parish Register.

‡ Vol. ii., p. 264, for pedigree, which is in error in date of R. Hudson's birth. The wooden tablet in the chancel gives the year correctly.

§ *Ibid.* p. 246.

|| Parish Register, date illegible.

¶ Visit. London *Hart. Soc.* Vol. xv., p. 397.

** Parish Register.

†† "Mrs. Jeane the wife of Mr. Robert

Hudson, was buried," *ibid.*

§§ Burial of Ann Hudson not in this register.

wife's son" £10 when 21; to "my father and mother Walker" 50s. each; to sister Peinnston and sister Small 50s. each; to sister Francis Raynes for life £20 a year out of rectory of Melton; to parson and churchwardens of St. Mary Bothaw, £6 6s. od. a year for ten years after his death; to these trustees, John Longfoote of Melton, Hugh Hubbert, Henry Spenser of Boston, yeoman, James Brewin, nephew Thomas Hudson, and Michael Baylie, £4 14s. 6d., out of rectory of Melton, they to pay £1 to vicar of Melton for sermon on Tuesday after Twelfth day each year, 2s. 6d. to clerk, £1 to vicar and wardens for a dinner, £2 12s. od., by 12 pence each Sabbath day in bread to poor of Melton; to the same trustees £15 6s. 8d. a year, out of rectory of Melton, to six poor alms-men; also £200 for building an alms-house for them in Melton;* all other goods and lands to "only son" Henry Hudson, his executor.

In his codicil, R. Hudson desires to be buried in the chancel of Melton church, "because I was born there and the chancel belongs to me and my heirs;" he revokes the legacy of £25 to the Haberdashers' Co., the gift for sermon in St. Mary Bothaw, and the £200 for the bede-house which he has built himself, but leaves £3 a year more for benefit of the alms-men; he leaves to Mr. Walker, "my father-in-law," £5 for poor in Chiswick;† and orders no legacies to be paid to the executors of those who have died since his will was made.

Robert Hudson's only surviving son Henry was baptized at St. Mary Bothaw, on 11th July 1609: ‡ he was made a baronet on 3rd July, 1660.

Over the door of the bede-house built by R. Hudson are his arms; *Per chevron embattled Argent and Gules three escallofs counterchanged*; Crest; *a griffin's head erased Argent gorged with a mural crown Gules charged with three escallofs of the first*. These arms are also now in the window of the South aisle of the church nearest the West end.

In addition to the £18 6s. 8d. out of the rectory each year, R. Hudson's bede-house receives £5 a year for the rent of land at the back of the buildings, the same sum for rent of three acres in Ongar Lees, and £1 for rent of garden.

(b)

According to Mr. North, the old churchwardens' accounts do not extend to 1631, and therefore contain no entry relating to the purchase or gift of the second silver cup.§

(c)

The Rev. Simon Henley, the donor of the paten, was the son of the Rev. John Henley, M.A., vicar of Towcester, Northants., by Anna, his wife, and was born at Towcester on 12th Aug., 1664, being baptized on 9th Sep. || Simon Henley was admitted to Benet College, ¶ Cambridge, in 1679, from whence he took his B.A. degree in 1683, and M.A. in 1694. He passed most of his clerical life at Melton, for in 1687 he was curate to the Rev. John Dowell, vicar of Melton, who died in 1690, and was then appointed as his successor. This post he occupied for forty years so faithfully that he is "said to have been one of the best parish priests in England, a pattern of sanctity and of the pastoral care."** He died on 5th June, 1731. Mr. Henley

* Vide *Reports of Commissioners for Charities*, Vol. xvii., p. 441. † Registers of Chiswick begin in 1678.

‡ Parish Register. § I should mention that I have failed to find the original documents. || Parish Register.

¶ The common name until recently of Corpus Christi College.

** See *Nichols*, Vol. ii., p. 259.

married at Melton on 1st Nov., 1691,* **Arabella Dowell**, the daughter of his predecessor, by **Mary**, his wife; by this lady he had a son, **John**, the celebrated "orator **Henley**," born on 3rd Aug., 1692; a daughter, **Arabella**, baptized on 19th Feb., 1693-4, who married **Richard Saunders**, on 4th Nov., 1718;* a daughter, **Elizabeth**, who died unmarried in 1740, bequeathing the interest of £10 to as many poor widows in Melton; and another daughter, **Mary**, baptized on 23rd March, 1697-8, who was married on 4th Oct., 1720 to Mr. **William Wright**, of Melton.* The donor of this paten and his wife, who died on 17th Dec., 1734, aged 70, were buried in the South transept of this church, an inscribed slab marking their graves.

(d)

The first flagon was purchased in accordance with the following clause in **Samuel Hartopp's** will, made on 27th Jan., 1635, and proved in Leicester in 1638 "I give unto the church of Melton ten pounds to buy a piece of plate for the communion table." **Samuel Hartopp** was the second son of **Valentine Hartopp** of Burton Lazars, by his wife **Anne**, the daughter and heir of **William Goodman** of Goadby, and was baptized at Melton on 9th April, 1584.* He was descended from the same ancestor as the other members of this ancient Leicestershire family, and was first cousin to Sir **Edward Hartopp**, 1st Bart. of Buckminster and Freeby, and to his younger brother **George**, founder of the **Hartopps** of Little Dalby.† **Samuel Hartopp** married **Bridget**, the daughter of **William Mason** of Egmonton, Notts., who apparently died before her husband, leaving no surviving issue. He himself died without issue, on 15th March, 1635, and was buried on the 21st* in accordance with his wish, expressed in his will, next to his elder brother Sir **William Hartopp**, Knt.,‡ at the entrance to the South transept in Melton church: over his grave is a large slab bearing a short Latin inscription.§

Samuel Hartopp left to Mr. **Cawdrey**, vicar of Melton, £2; the same sum to the poor of Burton Lazars, and £5 to the poor of Melton. His lease at Kneesall, Notts.,|| he bequeathed to his nephew, Sir **Thomas Hartopp**, Knt.; and legacies in money or plate to his servants, and to the following members of his family: sister-in-law Lady **Mary Hartopp**; sister Mrs. **Streete**, and her children **Anna** and **Joane**; brother-in-law **Nicholas Stringer**, and his son **Nicholas**; nieces **Anna Jobson** and **Elizabeth**, wife of **John Cooperley**.

The arms which Mr. **Hartopp** bore were, without the difference, the same as those granted to his cousin the 1st Bart., of Freeby, by Sir **William Segar**, Garter; which were subsequently adopted by all branches of the family, the chevron being afterwards tinctured Ermine. Owing to the donor's will not having been proved until 1638, this church did not obtain his gift until three years after his death.

* Parish Register. † For pedigrees see *Nichols*, Vol. ii., pp. 128, 267; and *Publica. of Harl. Soc.* Vol. ii., pp. 9 and 196.

‡ Buried 20 Feb., 1622-3. § *Nichols* by mistake gives "Gulielmi" instead of "Samuelis."

|| Which perhaps came to him through his wife.

As far as I know this flagon is the oldest piece of church plate in Leicestershire, for the purchase of which money was bequeathed by will.

(c)

Mrs. **Greene**, the donor of the second flagon and the alms dish, was **Mary**, the daughter of **Roger Waite**, mercer, of this town, by **Anne**, his second wife, and was baptized at Melton on 30th July, 1671.* Her father, a man of some consequence, was churchwarden in 1656; ten years later we find him issuing a $\frac{3}{4}$ d. token bearing the device of three bugle-horns taken out of his arms. **Roger Waite** died on 10th July, 1693; his wife **Anne** on 11th May, 1717. Their daughter **Mary** was married, first, to **William Parker**, Esq., barrister-at-law: secondly, at Melton, on 24th Sep., 1699, to **Charles Greene**, widower, Lieut. in Col. **Bayley's** regiment,* afterwards Lieut.-Col. in the Earl of **Peterborough's** dragoons: he died at the disastrous battle of Almanza in 1707, when **Charles**, King of Spain, assisted by the English and Dutch, was defeated by his rival, King **Philip**, assisted by the French. After the death of her second husband, Mrs. **Greene** retired to this her native town, where she lived for the remainder of her life; which came to a close in 1739. She was buried on the 7th of May, in the nave of Melton church, where, in the middle of the large West window, a monument was placed to her memory, at the top of which are the same arms as those on her gift of plate: this monument was moved when the window was restored in 1850, to its present position on the West wall of the South transept.† This lady helped to pay for the third church bell here in 1728.

In her will dated 23rd Oct., 1738, and proved P.C.C. with a memorandum dated 25th Oct., on 15th Aug., 1739, Mrs. **Greene**, left to **John Brown**, of Melton, clerk, and **Will. Reeve**, gent., of Melton, £500 in trust, for the benefit of her cousin, **Phillis Waite**, for life, then to **Mary Hopkinson**, daughter of **Will. Hopkinson**, of Upton, Northants, gent.: £300 in trust for the benefit of her godson, **Charles Green Say**; £50 in trust for benefit of **Martha Taverner**, for life, then to poor of Melton, as her trustees and the minister for time being think well;‡ To **Phillis Waite**, silver salver with arms of late husband, **Will. Parker**, engraved upon it: To **Thomas Cave**, curate of Melton, £5 and all her books on divinity: To Mr. **Hardy**, minister, of Melton, £5 and a £5 piece of **William and Mary**. To new pew the parish church of Melton £200. Very many legacies in money, plate, and furniture. Trustees appointed executors.

BURTON LAZARS.

SILVER CUP. Weight 8 oz. Height $6\frac{3}{4}$ in. Diam. of the bowl $3\frac{1}{4}$ in.; of the foot $3\frac{3}{8}$ in. Height of stem $3\frac{3}{8}$ in. Date 1798.

* Parish Register. † For inscription vide *Nichols*, Vol. ii., p. 255. ‡ Subsequently invested in the purchase of £67 os. 7d. 3 per cents.; the interest being distributed by the vicar.

Hall marks. 1. Capital Roman C in a square shield. 2. Leopard's head crowned in a rounded shield. 3. Lion passant in a plain oblong. 4. Head of **George III.** 5. W B., a pellet between, in a shaped oblong.

This cup has a straight-sided bowl, rounded off below, with a bell-shaped lip: a straight round stem with a small moulding for a knob, and a plain round foot. Upon the bowl is: "*Drink ye all of it.*"

SILVER CUP. Weight 7.5 oz.

Just like the first.

SILVER PATEN with a foot. Weight 5.6 oz. Diam. $6\frac{1}{4}$ in. Diam. of foot 3 in. Height of foot 2 in. Date **1706.**

Hall marks. 1. Court hand L. 2. Lion's head erased, 3. Britannia. 4. C. O. a long object and three pellets above, a rose between two annulets below, in a shaped shield. The mark of *Robert Cooper.*

This paten is flat with a small raised edge. The foot is a hollow drum, swelling out into a plain moulding. In the centre is the sacred monogram with a cross, within a circle of glory. Underneath the paten is "*The gift of George Burton to Burton Lazars a Hamblett of Melton Mowbray.*"

SILVER PATEN with a foot. Weight 5.5 oz.

Exactly like the last.

SILVER FLAGON. Weight 41.7 oz. Height $10\frac{1}{2}$ in. Diam. at top $3\frac{3}{8}$ in.; at the foot $5\frac{1}{2}$ in. Date **1790.**

Hall marks. 1. Small Roman P in a square shield. 2. Leopard's head crowned in an oval shield. 3. Lion passant in a plain oblong. 4. Head of **George III.** 5. R S in a plain oblong. Mark of *Robert Sharp.*

This is a straight-sided flagon narrowing to the top, with a round top to its lid. In front is this inscription: "*The gift of Philip Burton, Esq^r., to the extra parochial church of Burton Lazars, Aug^t. 1790.*"

George Burton, the donor of the two patens, owned a property in this parish and was the lessee of the manorial rights of Burton Lazars under the Bishop of **Ely**.^{*} He died on 18th Jan., 1758, aged 73, and was buried in this church; on the South wall of which is a white marble tablet to his memory. By his wife **Elizabeth Campion**, who died on 24th April, 1739, aged 54, he had fourteen children, of whom the eldest surviving son was **Philip Burton**, the donor of the silver flagon, who inherited his father's property in this parish, but lived principally in Hatton Garden, London, and in Eltham, co. Kent. He practised for some years as a solicitor and died on 17th Nov., 1792, aged 81, and was buried in Eltham churchyard, where there is a large monument over his grave. By his wife **Felicia**, who died on 30th Jan., 1791, aged 78, **Philip Burton** had an only daughter, **Felicia Elizabeth**, the wife of **George Horne**, D.D., Bishop of Norwich.

* *Nichols*, Vol. ii., p. 268.

FREEBY.

SILVER CUP AND COVER PATEN. Weight of cup 7.1 oz. Height $6\frac{1}{2}$ in. Diam. of bowl $3\frac{3}{8}$ in.; of foot $3\frac{1}{8}$ in. Height of stem $2\frac{3}{8}$ in. Date 1568. (PLATE II.)

Hall marks. 1. Small black letter L in a plain shield. 2. Lion passant. 3. Leopard's head crowned; each within a line shaped to the stamp. 4. A globe showing lines of latitude and longitude.

This is a pretty cup with a deep bowl nearly straight-sided in the lower part, swelling out higher up into a bell-shaped lip. The stem is evenly-balanced, being divided in half by a round moulding on a fillet, from whence it swells out into vertical edges, the reed ornament being round the upper one. The foot, which is a low one, is rounded off into a flat sloping edge. Round the bowl is a narrow moulding and an engraved band divided by three hour-glass curves. This cup was originally parcel gilt; plain traces of gilding are still to be seen round the ornamental band and round the knob and vertical edges of the stem.

SILVER COVER PATEN with a foot. Weight 2.3 oz. Diam. 4 in. Diam. of foot $1\frac{1}{2}$ in. Height of foot $\frac{3}{4}$ in. Date 1568. (PLATE II.)

Hall marks the same as those on the cup.

This is a plain cover of the usual Elizabethan shape.

PEWTER FLAGON. Height $10\frac{1}{2}$ in. Diam. at the top 4 in.; at the foot $4\frac{3}{4}$ in.

No marks.

This is a straight-sided flagon narrowing towards the top. It has a rounded lid surmounted with a knob, a plain handle, and thick solid purchase.

PEWTER DISH with a foot. Diam. $8\frac{1}{4}$ in. Diam. of foot $4\frac{3}{8}$ in. Height of foot 3 in.

Marks. 1. On the top "F.C.," for Freeby church. 2. Underneath, out of a ducal crown a nigger's head side-face, "James Anderton" round it, within an oval, repeated twice.

This is a flat dish with a raised gadrooned edge, standing on a hollow stem swelling out into a foot with a gadrooned edge; the same ornament running round the top of the stem.

PEWTER BASIN. Diam. $9\frac{1}{2}$ in. Depth $1\frac{1}{8}$ in.

Marks. 1. On edge, "Freeby Parish 1816." 2. On back, X crowned. 3. "Superfine hard metal," in a scroll. 4. In four small shapes; (a) Illegible. (b) Lion passant. (c) Leopard's head crowned. (d) Illegible. 5. R.S.

This is a plain basin for alms.

In 1568 the lord of the manor of Freeby was Edward, 3rd Earl of Rutland; thirty years later the manor passed to Thomas Hartopp, and in the possession of the elder branch of this ancient Leicestershire family it remained until it was sold by the late Sir J. W. Cradock Hartopp, Bart., to Mr. Daniel Thwaites, upon whose death in 1888 it passed to his only daughter, the wife of R. A. Yerburgh, M.P.

SYSONBY.

SILVER CUP WITH COVER PATEN. Weight of cup 5.5 oz. Height 6 in. Diam. of the bowl 3 in.; of the foot $2\frac{7}{8}$ in. Height of stem $2\frac{3}{8}$ in. Date 1568. (PLATE II.)

Hall marks. 1. Small black letter L in a pointed shield. 2. Lion passant. 3. Leopard's head crowned; each of the two latter having an outer line following its outline. 4. An illegible maker's mark.

The bowl of this pretty little cup, though nearly straight-sided, must strictly be called an inverted truncated cone. Its stem is evenly-balanced, swelling out at both ends, and divided in the middle by a round knob, covered with little horizontal strokes. The foot is of the usual shape. Two engraved bands run round the bowl, both being divided into three parts by hour-glass curves. Round the bottom of the bowl, at its junction with the stem, and round the flat edge of the foot, is the egg and tongue ornament. To all appearance the stem has lost its lower vertical edge, this having been probably taken out and not replaced, at some time when the cup needed repair.

SILVER COVER PATEN with a foot. Weight 1.5 oz. Diam. $3\frac{1}{4}$ in. Diam. of the foot $1\frac{1}{4}$ in. Height of the foot $\frac{3}{4}$ in. Date 1568. (PLATE 11.)

Hall marks the same as those on the cup, the maker's being equally illegible.

This paten is of the usual shape. Upon the outside round its flat edge is engraved a band of foliage, part of which is much defaced through having been rather roughly used when the paten was repaired at some former time. I may mention that the engraving of the rest of this band, as well as that of the two bands on the cup, is unusually fresh and sharp.

SILVER FLAGON. Weight 33.7 oz. Height $9\frac{1}{2}$ in. Diam. at the top $4\frac{1}{2}$ in.; at the foot $6\frac{1}{2}$ in. Date 1690.

Hall marks. 1. Small black letter N in a pointed shield. 2. Lion passant in a plain oblong. 3. Leopard's head crowned within a circle. 4. R.L., a quatrefoil below in a plain pointed shield.



Fig. 19.

This flagon in shape resembles the older one belonging to Melton. Its drum is straight-sided, narrowing towards the top. The lid has a flat top with flat projecting edge; the purchase is pierced in the shape of a heart. In front of the drum are these arms: *Quarterly, 1 and 4, Azure, two bars wavy Ermine, on a chief Or a demi lion rampant issuant Gules; Smith, of Hatherton; 2 and 3, per pale Or and Gules, three fleur-de-lis counterchanged; Smith, of Cuerdoley; upon an escutcheon of pretence, Argent, three text R's Sable; Pate, of Sysonby: Crest; an ostrich Gules, holding in the beak a horse shoe Argent; Smith, of Hough.* (FIG. 19.) Beneath the arms is the *Pate* motto: "*Pietas nunquam moritur,*" and "*The gift of the Lady Smith, of Sysonby.*" On the edge of the foot the lion passant is repeated; and beneath the foot is the weight 33 oz. 18 dwts.

The silver flagon was provided in accordance with the following clause in Lady *Smith's* will, made on 17th March, 1686, and proved P.C.C. on 3rd Feb., 1691, O.S.; "*I bequeath unto John Dowell now present incumbent and vicar of the parish church of Melton Mowbray and to Zachary Fenton, Clerke, his curate, the sum of £10 of lawful money of England in trust for them to buy plate for the communion service at the chapel of Sysonby, and not elsewhere, so soon as conveniently they can after my decease.*"

The donor was *Abigail*, the eldest daughter and co-heir of Sir *John*

Pate, Bart., of Sysonby, by his wife **Elizabeth**, daughter of Sir **William Skipwith**, Bart., of Cotes, and was baptized on 19th Sep., 1625, the ceremony being registered at Melton. This lady was descended from **Edward Pate** who was settled at Eye Kettleby early in the reign of **Elizabeth**, and who, late in that reign purchased Sysonby Grange. She married Sir **Thomas Smith**, 1st Bart. of Hatherton, co. Chester, and being left a widow on 8th May, 1675, retired to her manor house in this parish, which came to her from her father, who died in 1652, leaving no male issue surviving him. At this house, of which a small but interesting portion is still in use as a farm house, Lady **Smith** died on Christmas Day, 1691. She was buried in the South transept of Melton church, in which on the East wall is a mural monument to her memory, on which are the arms of **Smith** of Hatherton impaling those of **Pate**, and a long latin inscription which speaks of her as one who "*Afflictis rebus et secundis, æquam servavit mentem.*" This monument was erected by Sir **Thomas** and Lady **Smith's** only child and heir, **Frances Pate**, who married **Richard Lister**, Esq., of Thorpe Arnold, grandson of Sir **Martin Lister**, Knt., donor of plate to that parish.*

In addition to this piece of plate Lady **Smith** left £5 to the poor of Melton, and £2 to the poor of Sysonby. She also left in trust to the vicar and churchwardens of Melton and Sysonby for the time being, a half part of a field in Sysonby called **Cuthbert Wright's** close, containing about eight acres, the income to be spent in apprenticing poor children of both parishes. To Mr. **Dowell** the vicar, she left a mourning cloth gown to preach her funeral sermon in and £5. To Mr. **Fenton** the curate, the same kind of gown and £55. Many legacies were left to friends and servants. Her daughter **Frances Pate Lister**, she appointed her sole executrix and residuary legatee.†

WELBY.

SILVER CUP AND COVER PATEN. Weight of cup 5.6 oz. Height 5 $\frac{5}{8}$ in. Diam. of the bowl 3 $\frac{1}{2}$ in.; of the foot 3 $\frac{1}{8}$ in. Height of stem 2 $\frac{1}{4}$ in. Date circa 1634. (PLATE II.)

The maker's mark only is on this cup, this being: R.M., a cinquefoil below, in a shaped stamp.‡

The bowl is shaped into an inverted truncated cone with a flat base. The short stem is divided in half by a small knob, and from thence swells out to the bowl and into a plain foot, which has a few mouldings running round its edge. Upon the bowl are these arms: *Quarterly*: 1. and 4. *Argent a lion rampant Vert.* 2. and 3. *Gules a bend Or.* Crest: *A sun in splendour Or.* Jones.

* Vide p. 143. † For pedigree of Pate, of Eye Kettleby and Sysonby, see a paper by the late Mr. Thomas North, F.S.A., in Vol. xii., page 275, of the *Associated Societies' Reports*, and *Nichols*, Vol. ii., p. 283. ‡ *Old English Plate*, p. 320.

SILVER COVER PATEN with a foot. Weight 2.4 oz. Diam. 4 in. Diam. of the foot $1\frac{3}{4}$ in. Height of foot 1 in. Date *circa* 1634. (PLATE II.)

Maker's mark as on the cup.

This paten has a flat edge, the middle part is sunk flat, having in its centre a further depression $1\frac{3}{4}$ inch in diameter. The foot is a disk attached to the paten by a round stem swelling out to both ends.

PEWTER FLAGON. Height $10\frac{1}{2}$ in. Diam. at the top $4\frac{1}{2}$ in. At the foot $6\frac{1}{2}$ in. Date *circa* 1670.

Marks. 1. On the lid: an acorn between two guttée in a shaped shield, repeated four times. 2. On the bottom inside: "T.C." in a circle. 3. On the back of the handle "S.B."

This is a straight-sided flagon narrowing towards the top, with a wide foot and a flat top to its lid. The marks show it to have been the work of the pewterer who made the flagon at Hose.*

The arms on the cup show the donor of it to have been Sir **William Jones**, Knt., who was connected with this parish through his wife. He sprang from the Shrewsbury family of that name, and was the eldest son of **Isaac Jones**,† merchant, of London, by **Elizabeth**,† daughter of **Richard Prince**, of Shrewsbury.‡ He was lord of the manor of Berwick, co. Salop, which his father had bought in 1619, and was knighted at Whitehall, on 12th March, 1616-17.§ In about 1633, Sir **William Jones** married **Susanna**, daughter of **Edward Cotton**, of London, Esq., and widow of **George Bennett**, "the younger," of Welby;|| it was perhaps on his wedding-day that he made this gift to Welby church. **George Bennett's** father, who was living at his son's death, had bought the manor of Welby, and also that of Cotesbach in this county:¶ in the latter place Sir **William** and his wife chiefly lived. **Susanna Jones** died in 1640,** leaving no issue by her second husband, Sir **William**, who survived her for rather more than two years.

In his will dated 29th June, 1642, and proved with two codicils on 6th Feb., 1642-3, P.C.C., Sir **William Jones**, Knt., "late of Cotesbach," left to his son-in-law, **George Bennett**, a ring, with one diamond, worth £30; to his daughter-in-law, **Susanna Bennett**, one bracelet of pearl; to his brother, **Samuel Jones**,†† three broad gilt bowls, and a bed to his wife; to his brother, **Isaac**, broad gilt cup and cover; to his sister, **Marie Jones**, ring set with diamonds; to his cousin, **Walter Prince**, two broad bowls, parcel gilt; to his cousin, **Henry Gray**, Esq., gilt basin and ewer; to **Thomas**, son of **Henry Gray**, one doz. gilt spoons; to godson, **Edward**, son of cousin **William Jones**, of Lincoln's Inn, parcel gilt ewer and basin, and silver flagon; mourning to father and mother, brothers, and sisters; Sir **William Middleton** and his lady; brother **Longe** and his man; leases which **John Jackson** made "unto me," and **John Spencer**, dead, of lands in Ashby Magna, to be delivered to said **John Jackson**; all other goods to cousin, **William Jones**, of Lincoln's Inn, executor.

* P. 159. † Married 14th Jan. 1608: *Blakeway's M.S. Hist. of Berwick*. ‡ *Visit. of London; Publica. of Harl. Soc.* Vol. xvii. p. 18. § *Book of Knights*, by W. Metcalfe, F.S.A., p. 169. || Will dated 16th and proved, P.C.C., 26th Nov. 1630. ¶ *Nichols*, Vol. ii., p. 285 and Vol. iv., p. 148. ** Admon. dated 20th May, 1640, P.C.C. †† Afterwards of Courteenhall, Northants., Knt. and founder of the almshouse at Shrewsbury.

SCALFORD.

SILVER CUP. Weight 15.8 oz. Height $8\frac{1}{2}$ in. Diam. of the bowl $4\frac{1}{2}$ in.; of the foot 5 in. Height of stem $4\frac{1}{4}$ in. Date **1655**. (PLATE 7.)

Hall marks. 1. Court hand S in a plain shield. 2. Leopard's head crowned. 3. Lion passant, each in an outer shaped line. 4. H. W., a mullet below, in an oval shield.

This handsome cup has a straight-sided bowl with a flat base, and an evenly-balanced stem, divided in half by a large round knob. Mouldings run round the edge of the foot. In front of the bowl is this coat of arms within a lozenge: *Argent two bars Gules on a canton of the last a maunch of the first, Bardsey; impaling, Ermine a lion rampant Gules crowned Or, a border Sable bezantée, Cornwall.* Crests: *A wolf sejant, Bardsey; 2. A Cornish chough proper, Cornwall.* The arms divide this inscription: "*Ex dono Sarah Bardsey Vid. E.B. Theologicæ D.*"*

SILVER PATEN with a foot. Weight 6.4 oz. Diam. $5\frac{5}{8}$ in. Diam. of the foot $2\frac{3}{8}$ in. Height of foot $\frac{3}{8}$ in. Date **1655**. (PLATE 7.)

Hall marks as on the cup.

This paten, which fits on the cup with the foot downwards, has a flat edge, from whence the middle is sunk flat. The foot is a disk, attached to the paten by a thick round stem swelling out to both ends. In the centre of the paten is the same coat of arms as that on the cup.

PEWTER PLATE. Diam. $9\frac{5}{8}$ in.

Marks. 1. Out of a ducal crown a dexter arm embowed vambraced, the hand holding a spear. 2. London. 3. X crowned. 4. In four small shapes: (a) S. H. (b) A fleur-de-lis. (c) A dexter arm holding a spear. (d) Per chevron engrailed three leopards' faces.

According to Archdeacon **Bonney** there was here in 1832 a "large pewter flagon" given by **Sarah Bardsey**, bearing the same arms and inscription as the silver cup. Nothing is now known of this.

The donor of these pieces I take to have been a daughter and co-heir of **Richard Cornwall**, of Haverhill,† co. Essex, another of whose daughters married **Thomas Fabian**, of London.‡ **Sarah Cornwall** married in 1613 the Rev. **Edmund Bardsey**, a member of a branch of the Lancashire family of that name, that had been settled in this parish for some years.§ He was a son of **Nevill Bardsey**, of Scalford, by his wife **Margery**, and was baptized here on 19th June, 1586.¶ He was admitted to Queen's Coll., Camb., on 26th May, 1602, and was elected a fellow of the college in 1608;¶ resigning his fellowship upon his marriage, he was soon after inducted into the rectory of Hickling, co. Notts., to which parish he presented the chalice and paten still there, in 1622, the same year in which he took the degree of D.D. Mr. **Bardsey** was presented to the

* "The gift of Sarah Bardsey, widow of E. B., D.D." † The early registers of Haverhill are not to be found

‡ *Visita. of London. Publica. of the Harl. Soc.* Vol. xv., p. 262. § *Nichols*, Vol. ii., p. 317.

¶ Parish Register.

¶ *Ex inform.*, W. G. Searle, author of *Hist. of Queen's Coll. Camb.*

vicarage of Scalford in 1617; here he principally lived, and in 1639 helped no doubt towards the rebuilding of the church tower, which had fallen down, on the South side of which are to be seen his arms; the arms of **Bardsey** are also cut in stone over the chancel arch of this church, on the East side. The Rev. Dr. **Bardsey** was buried here on 27th Feb., 1653-4*

In his will, made 2nd Feb., 1651, and proved 10th June, 1654, P.C.C., **Edmund Bardsey**, of Scalford, D.D., desired to be buried in the chancel of Scalford church, and left to his wife, **Sarah**, the advowson of Hickling, Notts; and also the impropriate portion of tithe or tenths growing and coming out of sixteen oxgangs of land in Hickling, "heretofore belonging to the Monastery of Thurgaton, Notts., which came to me by way of purchase from Master **John Duckett**." All personalty to wife **Sarah**, his sole executrix.

Sarah Bardsey, survived the Dr. for many years, and died without surviving issue, being buried here on 22nd Nov., 1676.*

In her will, made 7th May, 1672, and proved in Leicester, on 21st April, 1677, **Sarah Bardsey** of Scalford, widow, desired to be buried next her husband, and left to the poor of Scalford £2, and of Hickling £3: to nephew **Cornwall Hampton** the "house I live in," and homestead bought of **John flann**; also that portion of impropriate tithes "which I have in Hickling." Legacies to **Richard Frisby** of Grantham, and to the daughter of "cousin **Fancott** born to him by his first wife **Elizabeth Bardsey**." To cousin **John Hunt**, son of niece **Elizabeth Hunt**, silver spoon double gilt. Perpetual advowson of rectory of Hickling, to **Queen's College, Oxford**.† Niece **Sarah Fabian**, residuary legatee and sole executrix. Seal, arms of **Bardsey** single.

Sarah Bardsey was the last of her name to be connected with this parish. Her son, **James**, B.D., had died unmarried on 27th, Oct., 1651, aged 37; ‡ and, in the same year as her husband, his brother, **Anthony Bardsey**, gent., had also died unmarried, being buried here on 13th May. She was executrix and principal legatee under the wills of both, which she proved on the same day as the will of her husband.

SOMERBY.

SILVER CUP. Weight 11 oz. Height $7\frac{5}{8}$ in. Diam. of bowl and of foot $3\frac{3}{4}$ in. Height of stem $3\frac{1}{2}$ in. Date 1810.

London hall marks.

This cup has a straight-sided concave bowl, rounded off in the lower part, having a bell-shaped lip; a straight and narrow stem with a small moulding for a knob, and a plain round foot.

SILVER PATEN with a foot. Weight 11.3 oz. Diam. 8 in. Diam. of foot 3 in. Height of foot $1\frac{1}{4}$ in. Date 1736.

* Parish Register. † Will endorsed as having been sworn to in a cause in Chancery between President of Queen's Camb., and Sarah Fabian. A search would probably show this to have been a friendly suit, owing to Oxford having been by mistake inserted in the will instead of Cambridge. ‡ To whose memory is a brass plate in the chancel here.

Hall marks. 1. Small Roman A in a plain shield. 2. Leopard's head crowned in a plain shield. 3. Lion passant in a plain oblong. 4. F—a pellet between in a heart-shaped shield; second letter illegible.

This paten has a hollow flat edge 1 in. wide, the middle part being sunk flat $\frac{1}{4}$ in. depth. The foot is a disk attached by a thick round stem swelling out at both ends. In the centre of the paten are these arms within a lozenge. *Three cocks*; **Cox** of Clent? *Impaling*; **Barry of ten on a chief, three leopards' faces.** (FIG. 20.)



Fig. 20.

PEWTER FLAGON. Height $11\frac{3}{4}$ in. Diam. of the top $4\frac{1}{8}$ in.; of foot $6\frac{1}{8}$ in.

No Marks.

This is a conical shaped flagon. It has an R shaped handle and a round top to its lid, on which is an acorn-shaped knob.

PEWTER PATEN with a foot. Diam. $8\frac{5}{8}$ in. Diam. of foot $4\frac{3}{8}$ in. Height of foot $2\frac{7}{8}$ in.

Marks. 1. X crowned. 2. "London." 3. In four small shapes: (a) J. I. (b) On a wreath a griffin's head erased. (c) In an oval shield upon a fess three escallops. (d) Per chevron engrailed three talbots' heads.

This is a flat paten with a raised edge and a hollow foot, narrowing into the middle.

TWO PEWTER PLATES. Diam. of each $9\frac{1}{4}$ in.

Marks. 1. X crowned. 2. A ducal crown with a fleur-de-lis between two crosses pattée above and a cross pattée between two palm leaves below; above all is "Joseph," and below "Spackman." 3. A rose crowned, above is "Made in," below "London." 4. "Cornhill London." These are ordinary shaped plates.

PEWTER BASIN. Diam. of top $8\frac{1}{2}$ in.; of foot $4\frac{1}{2}$ in. Height $3\frac{3}{4}$ in.

Marks. 1. X crowned, under which is "I & I."

In a terrier dated 1708 at Lincoln, the Somerby church plate is said to consist of "two pewter flagons, one silver chalice the weight of which is about 7 oz. so nigh as we could prove it; there is no inscription on it." This ancient cup and also one of the flagons had gone before 1832.

The churchwardens' accounts, which begin in 1775, contain no entry relating to the purchase or gift of the silver cup now here.

I have failed to identify the donor of the silver paten.



"'Sir,' said Sir Launcelot, 'I go to seek the adventures of the Sangreal.' 'Well,' said he, 'seek it ye may well; but though it were here ye shall have no power to see it; . . . 'and that is long on your sin.'"

GARTREE. FIRST DEANERY.

BOWDEN MAGNA.
CRANOE.
FOXTON.
GLOOSTON.
GUMLEY.
HUSBANDS BOSWORTH.

CHURCH LANGTON.
THORPE LANGTON.
TUR LANGTON.
LAUGHTON.
LUBENHAM.

MARKET HARBOROUGH.
SLAWSTON.
STONTON WYVILLE.
THEDDINGWORTH.
WELHAM.

BOWDEN MAGNA.

SILVER CUP. Weight 6.9 oz. Height 7 in. Diam. of the bowl $3\frac{3}{8}$ in.; of the foot $3\frac{1}{4}$ in. Height of stem 3 in. Date 1715.

Hall marks. 1. Court hand V. 2. Britannia. 3. Lion's head erased. 4. E.A., fleur-de-lis below, in a shaped shield. The mark of *John Eastt*: excepting the first letter this mark is most indistinct.

This cup has a straight-sided bowl, rounded off below and raised round the lip. The stem being $1\frac{1}{2}$ in. thick in its middle swells out towards each end: it has a large round knob. Round the edge of the foot is a large round moulding, and a few smaller ones.

SILVER CUP. Weight 7.6 oz. Height $6\frac{3}{4}$ in. Diam. of the bowl $3\frac{5}{8}$ in.; of foot $3\frac{1}{4}$ in. Height of the stem 3 in. Date 1737.

Hall marks. 1. Small Roman B in a plain shield. 2. Leopard's head crowned in a plain shield. 3. Lion passant in a plain oblong. 4. R.B., in a plain oblong. The mark of *Robert Brown*.

This cup differs little in shape from the first with the exception of its stem being without a knob.

SILVER PATEN with a foot. Weight 12.2 oz. Diam. 9 in. Diam. of the foot $3\frac{1}{2}$ in. Height of foot $2\frac{3}{8}$ in. Date 1704.

Hall marks. 1. Court hand I. 2. Lion's head erased. 3. Britannia. 4. L.E., a pellet between the letters, a rose between two pellets both above and below, within a circle. Mark of *Timothy Ley*.^s

This is a plain flat paten with a gadrooned edge. The foot is a hollow drum swelling out a little into a gadrooned edge. The lion's head erased is repeated under the foot. Underneath the paten are the initials W. M. and this inscription; "*The gift of the Revd. Mr Wotton, late Minister of Great Bowden, 1759.*"

SILVER PLATED PLATE. Diam. $7\frac{7}{8}$ in.

This is a plain plate, with some small mouldings round the edge.

SILVER PLATED FLAGON. Height 12 in. Diam. at the top $3\frac{3}{8}$ in.; at the foot $4\frac{1}{2}$ in.

^s *Gilda Aurifabrorum*. W. Chaffers, p. 176.

This is a jug-shaped flagon standing on a narrow round stem, which swells into a plain flat foot. It has a spout, a round top to its lid, an ornamental purchase and round handle. It is a good specimen of old silver plated work; both it and the plate are copper, silver-plated.

Archdeacon **Bonney** mentions in 1832 that one of the silver cups had been recently purchased; in that case it must have been in use in some other church.

The donor of the silver paten, **Richard Mowse Wotton**, was the son of the Rev. **John Wotton**, vicar of Market Harborough, and rector of Little Bowden, co. Northants., by **Mary**, his wife, and was baptized in that parish in Jan., 1700.* He matriculated at Christ Church, Oxford, on 12th March, 1717-18, and took his B.A. from thence in 1721. Having taken orders, he succeeded his father, at his death in 1724, in the rectory of Little Bowden, and in about 1736 was appointed by his college to the charge of Bowden Magna, holding both livings till his death on 18th April, 1758. **Richard M. Wotton**, who died unmarried, was buried at Little Bowden, in which church, on the South side of the chancel, is a tablet to the memory of himself, his sister **Anne Wotton**, niece **Anne Bockett**, and latter's daughter, **Ann Frances**, wife of Prebendary **Thomas William Barlow**.

The initials, I. ^{W.} M., on Mr. **Wotton's** gift, show that this paten originally belonged to his parents. He gave a paten, bearing a similar inscription, to Little Bowden church; both pieces were probably bequeathed by will.

CRANOE.

SILVER CUP. Weight 4.7 oz. Height 6 in. Diam. of the bowl $3\frac{1}{8}$ in.; of the foot $2\frac{5}{8}$ in. Height of the stem $2\frac{1}{2}$ in. Date *circa* 1725. (PLATE 14.)

The only mark is the maker's; A capital Roman M, with a mullet above and below, in a round stamp.

The bowl of this cup is nearly straight-sided, being slightly bell-shaped at the lip. The stem is thick, and has a small round moulding in the middle for a knob. No notice of this cup is to be found in the registers.

SILVER CUP. Weight 7.9 oz. Height $6\frac{3}{4}$ in. Diam. of bowl $3\frac{1}{4}$ in.; of foot $3\frac{3}{4}$ in. Height of the stem $4\frac{1}{2}$ in. Date 1876.

London hall marks.

This cup has a bowl shaped into an inverted truncated cone. Upon its foot are six circles, the sacred monogram being within one, crosses of various shapes in the other five. Underneath the foot there is "*Presented to St. Michael's church Cranoe, by Adeline Louisa Maria, Countess of Cardigan, 1876.*"

* Parish Register

SILVER PATEN. Weight 2.5 oz. Diam. 5½ in. Date 1876.

This paten has within a circle in its centre the "Agnus Dei," and also the same inscription as that on the last cup.

SILVER FLAGON. Weight 12.4 oz. Height 10½ in. Date 1876.

This is a jug-shaped flagon with a cross in front, and the sacred monogram on either side.

PEWTER CUP. Height 7½ in. Diam. of bowl 4 in.; of foot 4½ in. Height of the stem 3¼ in. Date 1699. (PLATE 9.)

No marks.

In the front of the bowl of this plain cup is the sacred monogram, with a cross above and three nails below, within a circle of glory. Starting from the edge a crack runs partly through the monogram, caused by that device having been cut too deep into the pewter.

PEWTER PATEN with a foot. Diam. 6½ in. Diam. of foot 3½ in. Height of foot 1¾ in. Date 1699. (PLATE 9.)

Mark. A small seeded rose between two sprays of foliage, "Jonas R. Sonnant 1699," above, "Durand" below.

The centre of this paten contains the same device as is to be found on the cup.

PEWTER FLAGON. Height 10½ in. Diam. of top 4¾ in.; of foot 6¾ in. Date 1699. (PLATE 9.)

Mark. On bottom inside, small seeded rose "Jonas" above, "Durand" below.

This is a straight-sided flagon, narrowing towards the top, with an R shaped handle. In front is the sacred monogram as on the cup.

PEWTER DISH. Diam. 8¼ in.

Marks. 1. A rose crowned. 2. An eagle displayed, with "London" below.

This plain dish evidently did not originally belong to the pewter set: it is a later addition.

Archdeacon **Bonney** mentions in 1832, that there belonged to Cranoe in addition to the pewter service, a "cup of bell metal in imitation of silver." If he referred, as is probable, to the ancient silver cup he was mistaken; for it is undoubtedly of silver: the same silversmith made a paten for North Kilworth in 1723, and another for Garthorpe in 1726.

The following is a copy of a memorandum made in the register of Cranoe, with respect to the gift of the pewter set of vessels.

"Memorand."

"Given by the Right Honble Elizabeth Countess of Cardigan to the parish church of Cranoe 1728. Imprimis one fine large damask cloth & one fine large damask napkin, for the communion table. Item. one large fine pewter flagon. Item. one large fine pewter dish. Item. one large fine pewter chalice. Item. one fine pewter paten. Richd. Eastway Rectr."

The large "pewter dish," similar no doubt to the one at Stonton Wyville, has unfortunately at some time or other disappeared. It was lost to the parish before 1832, since no mention is made of it by Archdeacon **Bonney**.

Lady **Cardigan**, the donor of this pewter service, was **Elizabeth**, eldest daughter of **Thomas Bruce**, 3rd Earl of **Elgin**, and 2nd Earl of **Ailesbury**, by his first wife, **Elizabeth**, only surviving daughter of **Henry**, Lord

Beauchamp, son of the 1st Duke of **Somerset**. Lady **Elizabeth Bruce**, married *circa* 1710, **George Brudenell**, 3rd Earl of **Cardigan**, the direct descendant of Sir **Robert Brudenell**, Knt., Chief Justice of common pleas, *temp.* **Henry VIII.**, who acquired the manors of Deene, co. Northants, and Staunton Wyville, Cranoe, and Slawston, in this county.*

Their marriage, the fruit of which was four sons and two daughters, has had a somewhat unusual effect upon the fortunes of the families of **Brudenell** and **Bruce**. In the first place their youngest son, **Thomas Brudenell**, was adopted, for want of surviving issue, by his maternal uncle, **Charles Bruce**, 4th Earl of **Elgin**, who bequeathed to him his estates; he, taking the name of **Bruce**, was afterwards created Earl of **Ailesbury**. Henceforth the Earls of **Ailesbury** of the new creation, though calling themselves **Bruce**, were really a younger branch of the family of **Brudenell**; consequently when the late Earl of **Cardigan** died in 1868 without issue, the Earldom of **Cardigan** and Barony of **Brudenell** passed to his remote cousin the late **George William Frederick Bruce**, 3rd Earl, and 2nd Marquis of **Ailesbury**.

George, 3rd Earl of **Cardigan**, died on his way home from Bath, on 6th July 1732,† and was buried at Deene on the 11th.‡ His widow, the donor of this service, survived until 1745, being buried at Deene on 14th Dec.‡

The arms of **Brudenell** are; *Argent, a chevron Gules between three morions Azure*: those of **Bruce** being, *Or, a saltire and chief Gules on a canton Argent a lion rampant Azure*.

Lady **Cardigan**, the donor of the three modern silver pieces, is the widow of **James Thomas**, 7th Earl of **Cardigan**, K.C.B., leader of the Balaclava charge, who died on the 27th March, 1868, and whom she married as his second wife, on 28th Sep., 1858. Lady **Cardigan** married secondly on 28th Aug., 1873, **Antonia Manuelo**, Comte de **Lancastre**.

These pieces were given during the incumbency of the Rev. **J. H. Hill**, F.S.A., rector of this parish from 1837, and of **Welham** from 1841, till his death on 3rd Dec., 1886. Mr. **Hill** was for many years one of the most valued working members of the Leicestershire Archæological Society.

FOXTON.

SILVER CUP WITH COVER PATEN. Weight of cup 5.9 oz. Height 5 $\frac{3}{4}$ in. Diam. of bowl 3 $\frac{3}{8}$ in.; of foot 2 $\frac{7}{8}$ in. Height of stem 2 $\frac{3}{8}$ in. Date 1567. (PLATE 13.)

Hall Marks. 1. Small black letter K, with annulet below in plain shield. 2. Lion passant. 3. Leopard's head crowned; each of these last two within a shaped outline. 4. An oblong eight pointed mark, in shaped outline.

This cup is much the same in shape as those at Goadby Marwood and Kimcote by the same maker. Its bowl is an inverted truncated cone, somewhat ogee-shaped, with a small moulding round its upper part. The stem, which has no knob, swells out into the usual vertical edges with rude horizontal lines running round. Round the edge of the foot is the egg and tongue ornament.

* Vide *Bridges' Hist. of Northants.* Vol. ii., p. 301: and for pedigree *J. H. Hill's Hist. of Langton*, p. 186
 † *Gents. Mag.* Vol. ii., p. 876. ‡ Parish Register.

SILVER COVER PATEN with a foot. Weight 2.1 oz. Diam. $3\frac{3}{8}$ in. Diam. of foot $1\frac{3}{8}$ in. Height of foot $\frac{3}{4}$ in. Date 1567. (PLATE 13.)

Hall marks. As on the cup, with the exception of the annual letter having no annulet beneath it. This paten is of the usual Elizabethan shape.

SILVER PLATED PATEN with a foot. Diam. $7\frac{1}{2}$ in. Diam. of foot 4 in. Height of foot $2\frac{1}{4}$ in.

This is a modern paten, plain in shape.

PEWTER FLAGON. Height $13\frac{1}{2}$ in. Diam. of top $4\frac{3}{8}$ in.; of foot $5\frac{3}{4}$ in.

The only mark is that of "E. C." on the back of the handle. Possibly the "E" is really a badly struck "F;" the initials would then stand for "Foxton Church." This is a straight-sided flagon narrowing to the top, with a round top to its lid surmounted by a knob.

TWO PEWTER PATENS with feet. Diam. of each $8\frac{1}{8}$ in. Diam. of foot $3\frac{5}{8}$ in. Height of foot $2\frac{1}{2}$ in.

Marks. 1. X crowned. 2. Between two pillars a hare supporting an altar flaming, "Edward," above: the surname below being hid by the foot, but from a pewter dish at Frolesworth we learn that this is "Leapidge." These are plain dishes made in imitation of silver.

GLOOSTON.

SILVER CUP WITH COVER PATEN. Weight of cup 4.7 oz. Height $5\frac{1}{2}$ in. Diam. of bowl $3\frac{1}{2}$ in.; of foot $2\frac{1}{2}$ in. Height of stem $2\frac{3}{4}$ in. Date 1601. (PLATE 14.)

Hall marks. 1. Lombardic D, external cusps, in plain shield. 2. Lion passant. 3. Leopard's head crowned; each of these two latter has a line following outline of mark. 4. I.B., with pellet below in shaped shield.

The bowl of this cup is V shaped, standing on a baluster stem rising out of a plain sloping foot.

SILVER COVER PATEN with foot. Weight 1.3 oz. Diam. $3\frac{1}{2}$ in. Diam. of foot $1\frac{1}{2}$ in. Height of foot $\frac{3}{4}$ in. Date 1609. (PLATE 14.)

This paten has one indistinct mark only, which is possibly the maker's, I.B., with a pellet below. Underneath the foot is "*The parish Koope of Glooston, 1609.*" Round the straight stem of the foot there is a chain ornament, being a succession of long dotted ovals placed upright side by side; between the ends of these ovals both above and below, is a pellet. This cover has the usual edge round the inside.

This cup, with its cover, is of a very pretty shape, and is an unusually early example of a V shaped cup with a baluster stem. The cover is of much thinner metal than the cup. This may be accounted for by the fact of the cup having been probably made originally for secular use, the cover having been made for it a few years after when it was purchased for the use of this church.

PEWTER PLATE, recently electro-plated. Diam. $8\frac{3}{4}$ in.

Marks. 1. Rose crowned. 2. J. A.

PEWTER DISH with foot, recently electro-plated. Diam. $8\frac{7}{8}$ in. Diam. of foot $3\frac{5}{8}$ in. Height of foot $2\frac{5}{8}$ in.

Marks. 1. Rose crowned with "London" below. 2. Upon a rose, a dove, above "John," with illegible surname. 3. X with "S. Hone" below. 4. In two small shields (a) I. S. (b) a crown.

MODERN GLASS JUG, with silver plated fittings.

In a terrier of 1745, the only plate mentioned is "one silver cup with a cover about 3 or 4 oz.;" which entry shows that the weight of church plate as given in the terriers cannot be relied on for being perfectly accurate.

GUMLEY.

SILVER CUP. Weight 11.3 oz. Height $8\frac{7}{8}$ in. Diam. of bowl $3\frac{1}{2}$ in.; of foot $1\frac{1}{4}$ in. Height of stem $4\frac{1}{2}$ in. Date 1765.

Hall marks. 1. Capital old English K. 2. Leopard's head crowned. 3. Lion passant. 4. I.B.W.B. Mark of *William Bond and John Phipps*.

The bowl of this cup is straight-sided, being slightly bell-shaped towards the top. Round its upper part there is an ornament of arched foliage repoussé, and in front within a wreath of foliage is engraved St. Luke ii. verse 14, in Greek. The stem has a small knob below the middle. Upon the foot is this crest: *On a wreath a dexter cubit arm, vambraced lying fesswise holding a sword erect with a bear's head on point; Cradock.* (FIG. 21.) Underneath the foot is "*Novr. 1765.*"



Fig. 21.

SILVER COVER PATEN with foot. Weight 3.7 oz. Diam. $4\frac{3}{8}$ in. Diam. of foot $1\frac{3}{4}$ in. Height of foot $1\frac{1}{8}$ in. Date 1765.

This paten has had the hall marks carelessly stamped upon it close to the foot: they are quite illegible. In the centre of this plain paten is the crest of the donor, and under the foot is "*Novr. 1765.*"

SILVER FLAGON. Weight 25.8 oz. Height $9\frac{1}{2}$ in. Diam. of top $3\frac{1}{4}$ in.; of foot $5\frac{3}{4}$ in. Date 1765.

Hall marks the same as on the cup.

This is a straight-sided flagon narrowing towards the top. In front is the same text of Scripture as that on the cup, below which is the crest of the donor. There is the same embossed arched foliage round the top and middle of the flagon as there is round the cup. Under the foot is the same date.

SILVER FLAGON. Weight 27.2 oz.

This flagon is the same as the other, with the exception of its being slightly wider round the foot.

SILVER DISH. Weight 16.3 oz. Diam. $9\frac{1}{2}$ in. Date 1765.

Hall marks the same as those on the cup.

This dish has the same foliage ornament as the rest of this plate round the edge and round the centre. The donors crest is on the edge of the dish, and underneath is the same date.

PEWTER BASIN. Diam. $9\frac{1}{4}$ in. Height $2\frac{1}{2}$ in.

Mark underneath, rose crowned with "London" below.

In Archdeacon **Bickham's** inventory of 1778, nothing older than the above service is mentioned.

The donor of it was **Joseph Cradock**, Esq., F.S.A., the representative of a younger branch of a family connected for many years with the town of Leicester.* He was the only surviving son of **Joseph Cradock**, of Leicester, by his first wife, **Mary**, daughter of Alderman **J. Annice**, of that town, and was born in Leicester, on 9th Jan., 1742. Having taken his M.A. degree from Emmanuel College, Cambridge, in 1765, Mr. **Cradock** settled at Gumley, which he had inherited in 1759 from his father, who had purchased it early in that century: he had begun, in 1764, to build the principal part of the present house at Gumley. This gentleman gained considerable distinction for his knowledge of literature, music, and the drama. He was the friend of **Johnson**, **Goldsmith**, and **Garrick**, as well as of most of the other literary men of the day, many of whom he frequently entertained with great hospitality in his new house at Gumley. The following were some of his own works, "Zobeide," a tragedy performed at Covent Garden Theatre, 1773: "Life of **John Wilkes**, Esq.," an ironical pamphlet, 1773: "An account of some romantic parts of North Wales," 1777: "Fidelia, or the prevalence of Fashion," a novel, 1821: "Literary and Miscellaneous Memoirs," 2 vols. The memoirs appeared just before his death, which took place in his rooms in the Strand, London, where he had been living for a few years, on 15th Dec., 1826: he was buried on the 23rd, in St. Mary's Church, in the Strand. Mr. **Cradock** married in 1765, **Anna Francesca**, third daughter and co-heir of **Francis Stratford**, Esq., of Merivale Hall, co. Warwick, which lady died without issue on 25th Dec., 1816. Before his death, he had made over his estate at Gumley, to his cousin and heir, Sir **Edmund Cradock-Hartopp**, 1st Bart.,† whose grandson, Sir **J. W. Cradock-Hartopp**, sold it in 1867 to his brother-in-law the present possessor, **T. C. D. Whitmore**, Esq., formerly Captain in the Royal Horse Guards, who has made considerable additions to the house built by the donor of this service of communion plate. Mr. **Cradock** bore these arms; *Or, three boars' heads coupéd Sable, between nine cross crosslets Gules.*

HUSBANDS BOSWORTH.

SILVER CUP. Weight 22.8 oz. Height 10 in. Diam. of bowl $4\frac{3}{4}$ in.; of foot $4\frac{3}{8}$ in. Height of stem $4\frac{7}{8}$ in. Date 1812.

* See *Nichols*, Vol. iii., p. 1149; *Hist. of Langton*, by J. H. Hill, p. 265, and *Gents. Mag.*, Vol. xcvii., part 1, p. 17.

† *Ibid.* p. 109.

London hall marks.

This is a large, plain, solid cup; having in the front of its bowl the sacred monogram, with a cross above and three nails below, within a circle of glory. Round the edge of the foot is "*The gift of Samuel Cotton 1767*," and underneath is "*Richard Pearce Rector emendavit 1812*." "*Husbands Bosworth*."

SILVER PATEN. Weight 13.7 oz. Diam. 8½ in. Date 1812.

London hall marks.

In the centre of this plain paten is also the sacred monogram arranged as on the cup. Underneath is "*Richard Pearce Rector emendavit 1812*." "*Husbands Bosworth*."

SILVER DISH. Weight 13.5 oz. Diam. 8½ in. Date 1812.

London hall marks.

This dish has the same inscription upon it as the paten, but is without the sacred monogram.

GLASS FLAGON with ormolu fittings.

This is a jug-shaped flagon of modern make.

The gift to the communion service of this church made originally by **Samuel Cotton** was a secular piece of plate; as is shown by this clause in his will, dated 8th April, 1767, and proved P.C.C., with a codicil dated 20th April, on 17th Oct., 1767: "*I also give and bequeath unto the parish of Husbands Bosworth in the said county of Leicester my large silver tankard to be applied for the service of the Communion Table in the parish church of Husbands Bosworth aforesaid to be kept for the use of the said parish among other sacrament utensils, and that my arms and name may be engraved thereon at the expense of my executors*." **Samuel Cotton** was the eldest son of **Bernard Cotton**, of Dadlington, co. Leicester, who sprang from the **Cottons** of Laughton, by **Rebecca**, daughter of Sir **Thomas Halford**, of Wistow, 2nd Bart., and was baptized on 5th May, 1699.* According to *Nichols*,† **Samuel Cotton** sold an estate in Dadlington, in 1729, to **Elizabeth Wright**, for £4200, and emigrated to Philadelphia, buying in 1733, 11,308 acres of land on the Jersey side of the river Delaware for £105; of which about 2,500 acres remained after his death which were sold by his heirs, the descendants of his three sisters, in 1772. It will be noticed, however, that this American property is not mentioned in his will, and that his sisters' descendants were not made in it his heirs. **Samuel Cotton** ended his days at Wistow, with which place he was doubly connected, since his uncle, Sir **Richard Halford**, Bart., had married his father's cousin, **Mary**, the daughter of **Will. Cotton**, rector of Broughton Astley. The only link that can be found between him and Husbands Bosworth, is the marriage of his great-aunt, **Anne Cotton**, with **Roger Smith**, a younger son of the lord of the manor of that place, **Roger Smith**, of Edmondthorpe. **Samuel Cotton** died unmarried on the 27th

* For pedigree see *Nichols*, Vol. iv., p. 724.

† *Ibid.*

April, 1767, and was buried in the chancel of Husbands Bosworth church, where was formerly over his grave a flat stone bearing a short inscription,* not now in existence.

According to the visitation of 1619 his family bore these arms; *Quarterly*; 1. *Argent, a bend Sable between three pellets*: 2. *Azure, an eagle displayed Argent*: 3. *Gules, three birds Or*: 4. *Barry nebuly of six, Argent and Gules, a canton of the last*.† The second quarter, the same arms as Cotton, of Connington, co. Hunts., was the coat borne by his family in his day, being displayed on a hatchment at Wistow, and on his brother's monumental slab formerly in the church of this parish.

Samuel Cotton, "of Wistow, gent.," left to **Lebeus Humphrys**, of Kibworth Harcourt, and **Robert Haymes**, of Great Glenn, in trust, a message in Angel Row, Nottingham, and all tenements and lands elsewhere, to be sold to pay the following legacies; To **Sir Will. Halford**, Bart., £200: To **Elizabeth Smalley**, late of Leicester, widow, and her three daughters, **Elizabeth**, wife of **Tho. Vowe**, **Ann**, wife of **Lebeus Humphrys**, **Hester**, wife of **James Vaughan**, £100 each: To **Charles Halford**, of the Borough of Leicester, Esq., £100: To **Nicholas Heygate**, of West Hadden, Northants, apothecary, £150: To **Eliza Frances**, daughter of **Joe Francis**, of Daventry, apothecary, deceased, £150: To **Mrs. Smith**, widow of **Edward Smith**, late of Edmondthorpe, £30: To poor of Husbands Bosworth, £5: To poor of Newton Harcourt and Kilby, £2 10s. each: To **Henry Green**, "nephew of my sister, **Mary Cotton**, deceased," £20: To **Mr. Iliff**, vicar of Kilby, 5 Guineas: Legacies to servants and labourers of **Sir W. Halford**: To **Sir W. Halford**, 3 pictures, "my own, my brother's, my aunt **Vernon's**:" To cousin **Ann Cotton**, widow of late **Rev. Shuckburgh Cotton**: to cousin **Halford Cotton**, and **Elizabeth, Mary, Lydia Cotton**, the son and daughters of **Shuckburgh Cotton**, £5 each. Message and lands in lordship of Sutton, in parish of Granby, Notts., to cousin **Charles Cotton**. All rest of personalty to **Sir W. Halford**, latter's nephew **Charles Halford**, and sister **Elizabeth Smalley**, with her daughters, share and share alike. Executors **Lebeus Humphrys**, and **Robert Haymes**.

Richard Pearce, at whose expense the sacred vessels formerly here were exchanged for those now in use, was the son of **Richard Pearce**, of Westminster, Esq., and was born in 1759.‡ He matriculated into Magdalen Hall, Oxford, on 9th May, 1787;§ but took his degree of LL.D. from Queen's Coll., Camb., in 1795, having been instituted on 2nd Dec., 1790, to the rectory of Husbands Bosworth; (**Richard Pearce**, patron.)|| **Mr. Pearce** died here, unmarried, and was buried at Flamstead, Herts, on 5th Jan., 1814, aged 55.¶

From the will of the **Rev. Richard Pearce**, made 30th March, 1813, and proved with four codicils on 11th May, 1814, P.C.C., we learn that he owned house property in St. Margaret's, and St. John the Evangelist's, Westminster; the manor of Flamstead; advowson of Husbands Bosworth, and property in Rushden, Northants. His "cousin **Thomas Pearce**, late of Newgate Street, wine merchant," was one of his executors, and his principal legatee.

* *Nichols*, Vol. ii., p. 469. † *Pub. of Harl. Soc.*, Vol. ii., p. 191. ‡ Probably elder brother to **James Pearce**, son of **Richard** and **Ann**, born 22 March, baptized 13 April, 1760, at St. Margaret's, Westminster. § *Alumni Oxonienses*, J. Foster. || Bishop of Lincoln's Registers. ¶ Parish Register.

CHURCH LANGTON.

SILVER CUP WITH COVER PATEN. Weight of cup 8.8 oz. Height $6\frac{1}{2}$ in. Diam. of bowl $4\frac{3}{8}$ in.; of foot $3\frac{3}{8}$ in. Height of stem $3\frac{1}{4}$ in. Date *circa* 1575. (PLATE 13.)

Only one mark, a rose.

The bowl of this cup is an inverted truncated cone with concave sides, and flat projecting base: round its middle is a band of stroke ornament divided into six parts by hour-glass curves. Round both ends of the usual evenly-balanced stem, and round the edge of the foot is the vertical reed ornament.

SILVER COVER PATEN with foot. Weight 3.7 oz. Diam. $4\frac{1}{8}$ in. Diam. of foot $1\frac{1}{8}$ in. Date *circa* 1575. (PLATE 13.)

Upon the flat edge inside is stamped R M very roughly.

This cover is somewhat dome-shaped. It has a rim rather deeper than usual to cause it to fit on to the cup. The foot is a plain round button attached to the cover by a short stem.

SILVER CUP. Weight 10.5 oz. Date 1874.

This cup has a globular bowl bearing this text; "*I will take the cup of salvation and call on the name of the Lord.*" The stem is round with a large plain round knob. The foot is hexagonal, and has the sacred monogram engraved upon it.

SILVER PATEN. Weight 3.9 oz. Diam. 6 in. Date 1874.

Round the edge of this paten is engraved a trefoil ornament, and in the centre within a quatrefoil, a maltese cross. Underneath is "*Jesus said unto them I am the bread of life.*"

SILVER FLAGON. Weight 21 oz. Height $12\frac{3}{4}$ in. Date 1874.

This is a jug-shaped flagon, having within a quatrefoil in front this text, "*He that believeth on me shall never thirst,*" with the initials of the donor "J. E. O." below.

PEWTER FLAGON. Height $10\frac{1}{2}$ in. Diam. at top $4\frac{1}{2}$ in.; at foot $5\frac{1}{2}$ in.

Marks. 1. Lion passant, repeated twice. 2. Leopard's head, also repeated twice.

In shape this flagon is straight-sided, with a flat top to its lid.

In the terriers of 1712 and 1715, the church plate mentioned here is; "a silver cup with a cover weighing 13 oz. or thereabouts."

The new communion service, as well as the modern communion plate belonging to Tur Langton church, was given by Miss **Jemima Elizabeth Ord**, who owned and resided at West Langton Hall. This lady was the second daughter of the Rev. **James Ord**, of West Langton Hall, by **Barbara**, fourth daughter of **Charles Brandling**, Esq., of Gosforth House, Northumberland; she was born on 16th July, 1791. These two sets of communion plate, valuable though they be, are but small examples of the many gifts offered to God and the church, during her long life, by this benevolent lady. She contributed largely towards the restoration of the two churches in Church and Thorpe Langton, and was also one of the principal subscribers to the

fund for erecting the new church in Tur Langton. Miss **Ord**, succeeded to a life interest in the Langton estates at the death of her brother, **James Ord**, Esq., in 1863. Their father the Rev. **James Ord**, was the first of this name to possess the Langton property. He inherited it from two sisters, Miss **Pickering**, and Mrs. **Byrd**, who were his godparents and relatives, he being descended from the **Pickerings** through his mother, **Ann Dillingham**, who was the granddaughter of **Elizabeth Pickering**, who married **Thomas Dillingham**, master of Emmanuel College, Cambridge. The Rev. **James Ord**, was a younger son of **William Ord**, Esq., the representative of a Northumberland family, settled at Fenham, in that county.* His daughter, Miss **J. E. Ord**, died on 2nd Feb., 1876, after a long life spent in kindly benevolence. She was buried, by her own desire, in Tur Langton churchyard, on the North side of the new church; over her grave is an altar-tomb, on the top of which is a latin cross and a short inscription, concluding with the words; "*I know that my Redeemer liveth.*"

There has also been placed to her memory two painted windows, one in the East end of the North aisle of Church Langton church, in which the Christmas subject, the angels appearing to the shepherds, has been rendered in a striking and tasteful manner; another in the West end of Tur Langton church: which was "erected by her friends and neighbours, Dec. 25th, 1877." Miss **Ord** is now represented by her niece **Elizabeth Barbara**, the daughter of her younger brother the late Rev. **T. C. Ord**, rector of Gaulby, and the wife of **Francis E. Bigge**, Esq., who also springs from a Northumberland family. Mr. and Mrs. **Bigge**, who now reside at Hennapyn, Torquay, are the possessors of an excellent portrait in crayon of Miss **Ord**, and of an interesting collection of oil paintings of other members of their family. The arms of **Ord** are: *Sable three salmon haurient Argent.* Crest: *An elk's head couped Proper.*

THORPE LANGTON.

SILVER CUP. Weight 7 oz. Diam. of bowl $3\frac{1}{2}$ in.; of foot $3\frac{3}{8}$ in. Height of stem $2\frac{3}{8}$ in. Date 1731.

Hall marks. 1. Capital Roman Q in plain shield. 2. Leopard's head crowned. 3. Lion passant. 4. W.

The bowl of this cup is straight-sided in shape resting on a very thick stem which has a small moulding for knob near the top.

PEWTER PATEN. Diam. $8\frac{3}{8}$ in.

Marks. 1. Rose crowned. 2. Eagle displayed, below "London."

PEWTER DISH. Diam. $9\frac{1}{2}$ in.

Marks. Leopard's head repeated four times.

* See *The History of the Parish of Langton*, by the Rev. J. H. Hill, B.A., F.S.A., p. 44.

TUR LANGTON.

SILVER CUP AND COVER PATEN. Weight of cup 7 oz. Height $5\frac{7}{8}$ in. Diam. of bowl $3\frac{3}{8}$ in.; of foot $3\frac{1}{2}$ in. Height of stem 3 in. Date 1634. (PLATE 13.)

Hall marks. 1. Italic R in a plain shield. 2. Lion passant. 3. Leopard's head crowned, each of the two last being within a shaped outline. 4. An escalop shell within a stamp of same shape.

The bowl of this cup is an inverted truncated cone with a flat base, standing upon a round stem, across the upper part of which is a disk $1\frac{3}{8}$ of an inch in diameter. The lower part of the stem swells out into a foot ending in a vertical and flat edge; underneath which the lion passant is repeated.

SILVER COVER PATEN with a foot. Weight 1.9 oz. Diam. $3\frac{3}{4}$ in. Diam. of foot $1\frac{1}{2}$ in. Height of foot $\frac{5}{8}$ in. Date 1634. (PLATE 13.)

No hall marks.

This is a very plain cover; being nearly flat in shape with its edge turned up inside $\frac{1}{4}$ of an inch in depth to make it fit on to the cup. The foot is a disk attached to the paten by a thin round stem swelling out at both ends.

TWO SILVER CUPS. Weight of each 13.6 oz. Height $7\frac{7}{8}$ in. Diam. of bowl 4 in.; of foot $5\frac{1}{8}$ in. Date 1865.

The bowls of these cups bear this text in old English letters. "*I will take the cup of salvation and call upon the name of the Lord.*" The stem, knob, and foot of each is hexagonal in shape. Underneath the foot are the initials of the donor "J. E. O."

SILVER PATEN with a foot. Weight 8.6 oz. Diam. 7 in. Date 1865.

Round the edge of the paten is this text. "*Jesus said unto them I am the bread of life.*" Underneath is "*This service consisting of 5 pieces was a gift to Tur Langton church, from Jemima Elizabeth Ord, 1866.*"

SILVER ALMS DISH. Weight 10 oz. Diam. $8\frac{1}{8}$ in. Date 1865.

Round the edge of this dish is this text, "*God loveth the cheerful giver.*" In the centre is the sacred monogram and underneath the same inscription as on paten.

SILVER FLAGON. Weight 21.5 oz. Height $12\frac{1}{4}$ in. Date 1865.

This is a jug-shaped flagon having round the middle this text, "*He that believeth on me shall never thirst.*"

PEWTER FLAGON. Height $8\frac{1}{2}$ in. Diam. at the top $3\frac{3}{4}$ in. At the foot 5 in.

Mark. On the bottom inside: a stag courant, "H" above, "1714" below, within a dotted circle. This is a straight-sided flagon narrowing towards the top. It has a rounded top to its lid, and the usual handle and purchase. Round the foot run a few narrow mouldings.

PEWTER PLATE. Diam. $9\frac{3}{8}$ in.

Marks. 1. On the edge; leopard's head repeated four times. 2. On the back; a lion rampant between I. R. within an oval.

This plate has a flat edge $2\frac{1}{4}$ inches wide, the middle part is sunk flat $\frac{1}{4}$ of an inch in depth.

PEWTER PLATE. Diam. $9\frac{1}{2}$ in.

Marks. 1. Escalop shell, "Henry" above, "Joseph" below. 2. X crowned. 3. "Superfine hard metal made in London."

The modern silver service was presented by Miss Ord,* in the year the new church here was built on a different site to the ancient one, a small fragment of which latter still remains standing.

LAUGHTON.

SILVER CUP. Weight, including lead in stem 8.9 oz. Height $6\frac{3}{4}$ in. Diam. of bowl and of foot $3\frac{3}{4}$ in. Height of stem $3\frac{1}{2}$ in. Date 1781.

Hall marks. 1. Small Roman F in a square shield. 2. Leopard's head crowned in plain shield. 3. Lion passant in plain oblong.

This cup has an egg-shaped bowl standing on a very narrow plain stem without a knob which has been filled with lead, the probable cause of a crack in the stem near the top. There is a small beaded ornament round the edge of the foot. This was probably originally made for a secular cup.

SILVER PATEN. Weight 3.8 oz. Diam. 6 in. Date 1880.

London hall marks.

This paten has in its centre the sacred monogram gilt, within a circle of glory.

PEWTER DISH. Diam. $8\frac{3}{4}$ in.

Marks. 1. Rose crowned. 2. W.C. 3. London.

This was formerly used as the paten.

PEWTER FLAGON. Height $10\frac{1}{4}$ in. Diam. at top $3\frac{3}{4}$ in.; at foot $4\frac{3}{8}$ in.

No marks.

In shape this is a straight-sided flagon narrowing towards the top.

PEWTER BASIN. Diam. $10\frac{1}{8}$ in. Height $2\frac{3}{4}$ in.

Marks. 1. An indistinct coat of arms with "Birch," and another name beneath. 2. "London."

This is a perfectly plain basin.

TWO GLASS CRUETS.

One of these small modern pieces has silver, the other plated fittings.

In the terrier of 1724 we are told that there was then here; "A silver cup weighing about 4 oz. inscribed, 'For the town of Lowton;' a pewter flagon." The cup had ceased to exist by 1832.

The silver paten and glass cruets were presented to the church at its restoration in 1880.

* *Vide* p. 187.

LUBENHAM.

SILVER CUP WITH COVER PATEN. Weight of cup 5.8 oz. Height 6 in. Diam. of bowl $\frac{1}{2}$ in.; of foot $3\frac{1}{4}$ in. Height of stem $2\frac{3}{4}$ in. Date *circa* 1575. (PLATE 13.)

Only one mark, a rose.

This cup is very similar in shape to the one at Church Langton with the exception of its having a narrower stem, and round the bowl three bands of stroke ornament joined together, each band being divided into six parts by hour-glass curves.

SILVER COVER PATEN. Weight 2.8 oz. Diam. $4\frac{1}{8}$ in. Height $1\frac{1}{8}$ in. Date *circa* 1575. (PLATE 13.)

No marks.

This cover, which fits on to the cup both ways is dome-shaped, and is unusually high. It has a flat edge about $\frac{3}{8}$ in. wide at right angle to the dome, with the usual rim inside. The foot is broken off; no one now living can remember its existence. It was evidently a plain button about 1 in. diameter, with a short stem which, as may be seen by the broken part, was $\frac{1}{8}$ in. thick. When the dome-shaped cover is placed on the cup, the outline and proportions of both together are very good.

PEWTER DISH. Diam. $9\frac{3}{8}$ in.

Marks. 1. On edge 4 lions' faces in as many small plain shields. 2. On the back within a circle a lion rampant between I. B. or P.

This is a perfectly plain dish.

PEWTER FLAGON. Height $11\frac{1}{4}$ in. Diam. of top $4\frac{5}{8}$ in.; of foot $5\frac{3}{4}$ in. Date 1635. (PLATE 9.)

One mark, possibly a monogram, an I. between B. A. On the right hand side of this mark there is "35" with "B." below. The first part of the date and the first letter, have missed being struck. The date is no doubt 1635. As far as I know this is the oldest piece of pewter church plate in this county.

This is a round-bellied flagon with a plain handle and solid purchase, and is a late example of this particular shape. Mr. Cripps mentions 1615 as about the date when this shape was last in general use.*

MARKET HARBOROUGH.

SILVER CUP. Weight 14.3 oz. Height $9\frac{1}{4}$ in. Diam. of the bowl $3\frac{1}{2}$ in.; of the foot $4\frac{1}{4}$ in. Height of stem 5 in. Date 1753.

Hall Marks. 1. Small Roman S in a shaped shield. 2. Leopard's head crowned. 3. Lion passant. 4. T. W.

This cup has a bell-shaped bowl, resting on a baluster stem which rises out of a plain round foot. On the bowl is "*Deo et Ecclesiz.*"

* *Old English Plate*, p. 187.

SILVER PATEN. Weight 12.5 oz. Diam. 9½ in. Date 1753.

Hall marks as on the cup.

This is a plain paten with the same inscription in the centre as that on the cup.

SILVER DISH with a foot. Weight 15.8 oz. Diam. 9½ in. Height 2¾ in. Diam. of foot 3⅜ in. Date 1753.

Hall marks as on the cup; and the same inscription in the centre.

SILVER FLAGON. Weight 51.9 oz. Height 12⅜ in. Diam. of the top 3¼ in.; of the foot 7⅝ in. Date 1753.

Hall marks as on the cup.

This flagon is in shape straight-sided, narrowing towards the top. It has a large spreading out foot, and a round top to the lid. In front is the same inscription. This set of communion plate is a very good example of the plain and solid character of church plate made in the middle of the last century.

SILVER ALMS DISH. Weight 20.8 oz. Diam. 9½ in. Date 1882.

This is a perfectly plain dish with "*Deo et Ecclesie*" in the centre.

PEWTER DISH.

Marks. 1. "London" over a crown. 2. A thistle surrounded by "**Francis Pigott.**" 3. A rose crowned. 4. T.T., Britannia, and lion's head erased, each in a small shield.

The following extract from p. 20, of Mr. **Rowland Rouse's**, MS. history of Market Harborough will throw some light on the origin of the principal part of the communion plate belonging to this parish; this being an extract which Mr. **Rouse** himself took out of the churchwardens' accounts.

"1753. Paid **John Spence** for exchanging the old pewter flaggon and 2 old silver cups for a Dec. 30. new set of communion plate consisting of a silver flaggon 2 silver plates and a silver cup, on each of which is engraved this motto "*Deo et Ecclesie*;" their weight is 95 oz. at 7s. 2d. or 7s.—£33 10s. od. or about £34 os. od.

Received by the 2 old cups etc..... £10 os. od.

The gift of M^{rs} Elizth Walker exclusive of a very handsome table-cloth and 2 napkins £20 os. od.

Paid by the parish about £3 10s. od. or £4 os. od."

Elizabeth Walker, "a maiden lady" the donor of £20 towards the purchase of this communion service, sprang from a Market Harborough family of gentle birth, mentioned in the visitation of 1619.* She was the daughter of **Richard Walker**, Esq., of this place, and was baptized at Market Harborough on 29th July, 1696.† Here she lived, and dying unmarried was buried at Broughton, co. Northants, on 18th Jan., 1758, where her eldest brother, **Rowland Walker**, had been buried on 29th July 1743.‡

* *Harl. Soc. Publications*, Vol. ii., p. 137.

† Parish Register.

‡ Parish Register.

In her will, made 9th Nov., 1753, and proved P.C.C., with a codicil dated 22nd April, 1757, on 11th Feb., 1758, **Elizabeth Walker**, "spinster of Market Harborough," left a messuage in Market Harborough, with home close bought by her and her late sister **Katherine Walker** from **Richard Hatton**, gent., and also dovecot close bought by her from **Richard Hatton**, to her nephew **Christopher Hatton Walker**,* son of her late brother **Richard Walker**.† All land in Pytchley and elsewhere, to her sister **Anne**, wife of **Rev. John Mapletoft** for life, then to be sold and proceeds paid in equal shares to nephews **Richard**, **John**, **Nathaniel**, and **Francis Mapletoft**, nieces **Elizabeth Mapletoft**, **Elizabeth** and **Rebecca Walker**. Rings to nieces **Alice Farrer** and **Anne Burford**. Silver salver to great-niece **Mary Farrer**, daughter of the **Rev. Tho.** and **Alice Farrer**. Executors and residuary legatees, nephews, **Christopher Hatton Walker** and **Richard Mapletoft**, of Banbury, Surgeon.

The arms of **Walker** are: *Azure a chevron between three crosses patté fitchée Argent.* Crest: *out of a ducal coronet a bull's head.*

The alms dish was presented to this church by an anonymous donor in 1882.

SLAWSTON.

SILVER CUP. Weight 4.5 oz. Height 5 $\frac{3}{4}$ in. Diam. of bowl 3 in.; of foot 2 $\frac{1}{2}$ in. Height of stem 2 $\frac{5}{8}$ in. Date 1570. (PLATE 14.)

Hall marks. 1. Small black letter N, with a mark over the second stroke, in plain shield. 2. Lion passant. 3. Leopard's head crowned; each of the two last marks have a line following their outline. 4. E T in monogram, within a shaped shield.

The bowl of this cup is straight-sided in shape, being concave in the middle, and having a flat base. It has a band of foliage round the middle, very unevenly engraved, divided into four parts by hour-glass curves. Round the upper and lower edges of the bowl there is an engraved line rising into ogee arches, at four equidistant places. The stem shows itself to be a later addition; the lower half, which is thicker than the upper, swells into a plain round knob, out of which the narrower upper half rises. The upper half may possibly be a part of the original stem. Beneath the foot the erroneous date, 1690, has in recent times been scratched.

PEWTER DISH, recently electro-plated. Diam. 8 $\frac{1}{2}$ in.

Marks. X crowned, and four indistinct small marks.

PEWTER DISH, electro-plated. Diam. 8 $\frac{1}{2}$ in.

Mark. "London."

PEWTER FLAGON, electro-plated recently. Height 10 $\frac{1}{2}$ in. Diam. of top 4 $\frac{1}{4}$ in.; of foot 5 $\frac{3}{8}$ in.

No marks.

This is a straight-sided flagon, narrowing towards the top.

* Rector of Harrington, Northants., ob. 28th Sep. 1799. † Ob. 13th July, 1751, both buried in St. Mary in Arden.

STONTON WYVILLE.

(a)

SILVER CUP. Weight 5.6 oz. Height $5\frac{5}{8}$ in. Diam. of bowl and of foot $3\frac{1}{2}$ in. Height of stem 2 in. Date 1826.

Sheffield hall marks.

This cup has an acorn-shaped bowl, the upper part being straight-sided; the lower part fluted. The stem, which has no knob, and also the foot are quite plain. This cup was no doubt made originally for secular purposes, traces of an obliterated inscription are visible.

SILVER PATEN with foot. Weight 4.8 oz. Diam. $5\frac{1}{2}$ in. Diam. of foot $2\frac{1}{2}$ in. Height of foot $1\frac{1}{2}$ in. Date 1736.

Hall marks. 1. Hibernia. 2. Harp crowned. 3. Capital old English Q. 4. W. —, the second initial being illegible. The harp crowned is repeated on the stem of the foot.

This paten which is quite plain in shape, is of Dublin make.

(b)

PEWTER CUP. Height $7\frac{7}{8}$ in. Diam. of bowl 4 in.; of foot $4\frac{1}{2}$ in. Height of stem $3\frac{3}{8}$ in. Date 1699. (PLATE 9.)

No marks.

The bowl of this cup which is straight-sided, has in front the sacred monogram, with a cross above and three nails below, within a circle of glory. The stem is thick and has a plain round knob. Starting from the edge there is a crack about $1\frac{1}{2}$ in. down the bowl, caused in the same way as the one in the Cranoe cup, by the too deep cutting of the monogram.

PEWTER PATEN with a foot. Diam. $6\frac{3}{8}$ in. Diam. of foot $3\frac{7}{8}$ in. Height of foot $1\frac{3}{4}$ in. Date 1699. (PLATE 9.)

Marks. Underneath; a small seeded rose with "Jonas R. Sonnant 1699" above. "Durand," below. Inside the foot part of the same mark is imperfectly repeated. In the centre of this paten is the same sacred monogram.

PEWTER FLAGON, electro-plated. Height $10\frac{7}{8}$ in. Diam. at top $4\frac{3}{4}$ in.; at foot $6\frac{1}{4}$ in. Date 1699. (PLATE 9.)

Marks. On the bottom inside; a rose, with "Jonas" above, "Durand" below; but imperfectly struck, and not legible except with the help of the mark on the Cranoe flagon.

This flagon was unfortunately electro-plated two or three years ago. It is straight-sided in shape with an R shaped handle and the sacred monogram in front.

PEWTER ALMS DISH. Diam. 14 in. Date 1699. (PLATE 9.)

Mark. A rose, with "Jonas R. Sonnant 1699" above, "Durand" below.

This alms dish, though made of modest pewter only, has certainly a worthier look about it than many of our modern pretentious brass ones.

PEWTER PLATE. Diam. $9\frac{1}{2}$ in.

Marks. 1. Rose crowned. 2. Probably a hare supporting a flaming altar. 3. "E Leapidge" in an oblong. 4. Three small illegible marks.

This is a plain plate with this inscription on it; "Stonton. W. Dunmore, Churchwarden, 1714."

In 1832 the pewter service was the only communion plate belonging to this church.

(a)

The silver cup and paten were presented by the late Rev. **Thomas Burnaby**, rector of this parish. This gentleman, a descendant of a younger son of the Rev. **Andrew Burnaby**, rector of Asfordby,* was the eldest son of the Rev. **Thomas Burnaby**, vicar of Blakesley, Northants, by his wife **Sarah**, the daughter of **Andrew Mieres**, solicitor of Daventry, Northants, and was born at Misterton, on 19th July, 1820. He was sent to St. Paul's school, London, in which he eventually became head boy and gained a scholarship taking him to Trinity College, Cambridge, from whence he took his B.A. degree in 1843. Mr. **Burnaby**, after leaving Cambridge, was for a few years second master at the Grammar School, Richmond, co. York; taking orders in 1847, he became curate of Badby and Newnham, Northants, which post he filled until 1850, when he acted as curate to his father for a few years at Blakesley; after which he took the curacy of Gaulby and from thence was appointed to the living of Stonton Wyville in 1860. Here he worked with much industry both in his parish and with private pupils. Chiefly by his endeavours a sum of money was raised for the rebuilding of Stonton Wyville church which work was finished not very long before his death. He died unmarried on the 23rd Dec., 1870, and was buried in this churchyard; a painted window in the church records his memory.

(b)

Archdeacon **Bonney** has made this note about the pewter flagon: "This was stolen on the 29th of Dec., 1831, and afterwards found at Hallaton."

With the exception of the last mentioned small plate the pewter communion service was given to Stonton Wyville, by the same lady who gave a similar service at the same time, to Cranoe, viz., **Elizabeth**, wife of **George Brudenell**, 3rd Earl of **Cardigan**. And an entry recording that fact was made by Mr. **Eastway** in the Stonton Wyville register.†

Mr. **Eastway**, the rector of Cranoe, apparently had charge of the neighbouring parish of Stonton Wyville, the rector of that place being non-resident.

THEDDINGWORTH.

(a)

SILVER CUP WITH COVER PATEN. Weight of cup 11.8 oz. Height 8½ in. Diam. of the bowl 4 in.; of the foot 3½ in. Height of stem 3½ in. Date 1720.

* For pedigree see *History of Market Harborough*, by J. H. Hill, F.S.A., p. 334. † *Ibid.* p. 179.

Hall marks. 1. Capital Roman E in a plain shield. 2. Britannia. 3. Lion's head erased. 4. S L, a pellet below in a shaped shield: the mark of *Gabriel Sleath*.

This cup has a bowl shaped into an inverted truncated cone with a raised lip. Its stem is thick and evenly balanced, being divided in half by a round moulding for a knob; from whence it swells out towards both ends. Some mouldings run round the edge of the foot, under which is the lion's head erased. Upon one side of the bowl is the sacred monogram with a cross and three nails within a circle of glory; on the other side is "*Deo et huic Ecclesie de Theddingworth Sacrum esse Voluit hoc Poculum Griffith Davies M.D. hujus Manerii Dominus. Anno Salutis 1722.*"*

SILVER COVER PATEN with a foot. Weight 6.4 oz. Diam. $5\frac{3}{8}$ in. Diam. of the foot $2\frac{1}{4}$ in. Height of foot 1 in. Date 1720.

Hall marks as on cup.

This paten has a flat edge with a moulding running round it from whence the middle part is sunk flat. The foot is a disk attached to the paten by a stem swelling out at both ends. Upon the foot is engraved the sacred monogram; and in the centre of the paten the same inscription as that on the cup.

SILVER PATEN with a foot. Weight 6.7 oz. Diam. 6 in. Diam. of the foot 2 in. Height of foot 1 in. Date 1722.

No hall marks.

This paten is much the same in shape as the other. In the centre is "*Patina Ecclesie de Theddingworth 1722.*"

(b)

SILVER FLAGON. Weight 16.3 oz. Height $10\frac{1}{2}$ in. Diam. at the top $1\frac{3}{8}$ in. At the foot $3\frac{3}{8}$ in. Date 1863.

London hall marks.

This is a plain jug-shaped flagon with a flat shaped handle and a cross pattée for a purchase. Upon one side of it is engraved the sacred monogram with a cross. Under the foot is scratched; "*This flagon was used for the first time on Sunday, May the 6th, in the year of grace 1866. F. H. Sutton, Vicar.*"

(a)

Dr. **Griffith Davies** the donor of the three older pieces, was the son of **William Davies**, gent., of Drysloyl, Carmarthenshire; he matriculated into Jesus Coll., Oxford, at the age of 17, on 17th Dec., 1684,† from whence he took his B.A. and M.A. degrees, finally taking that of M.D. on 4th July, 1698. Dr. **Griffith Davies** lived in St. Phillip's parish, Birmingham, and practised in that town as a physician; there he died on 24th Jan., 1722. He had become connected with Theddingworth, by buying from Sir **R. Newdigate**, Bart., circa 1715, the manor and advowson. Dr. **Davies** married in 1710, **Elizabeth**, only daughter of Sir **John Burgoyne**, 3rd Bart.; which lady died on 29th July, 1726, aged 47, leaving a daughter **Elizabeth**, who inherited

* "To God and this church of Theddingworth, Griffith Davies, M.D., lord of this manor, purposed this cup to be sacred. In the year of salvation 1722." † University Register.

her father's estates in this parish and took them to Sir **Thomas Cave**, Bart., of Stanford, whom she married in Nov., 1735.*

Dr. **Davies** and his wife were buried in the chancel of this church, where was formerly the large marble monument to their memory, moved in 1858 into the South aisle, at the top of which are these arms: *Or a chevron between three mullets pierced Sable; Davies; impaling, Gules a chevron between three talbots passant Argent, on a chief embattled of the last three martlets Azure; Burgoyne.*†

In his will, made 24th Jan., 1720, and proved with two codicils P.C.C. on 1 July, 1723, Dr. **Davies** ordered his estates in Carmarthen to be sold for the payment of debts and legacies; and left his books on Physic to Jesus Coll., Oxford; to rector and wardens of St. Phillip's, Birmingham, £50 towards buying an organ; to poor Housekeepers of Birmingham £20, to poor of Theddingworth £5, to sister **Alice Lloyd** an annuity.

It would seem that Dr. **Griffith Davies** made this gift of communion plate in his life-time, the inscription being placed on each piece perhaps after his death.

(b)

The Rev. **Frederick Heathcote Sutton**, M.A., the donor of the silver flagon, was the eighth and youngest son of the famous sportsman Sir **Richard Sutton**, 2nd Bart., by his wife **Mary Elizabeth**, daughter of **Benjamin Burton**, Esq., of Burton Hall, co. Carlow, and was born on 30th Sep. 1833. Having passed through Eton, and Magdalen College, Oxford, Mr. **Sutton** received deacon's orders in 1861, and was appointed to the curacy of Ketton, Rutland, in which county he had spent much of his early years under the care of his relatives and god-parents, Mr. and Mrs. **H. Heathcote**, of North Luffenham. From Ketton he came to this parish in 1864, remaining its vicar till 1873, when he was presented by his brother to the rectory of Brant-Broughton, co. Lincoln, where he died unmarried on 2nd March, 1888. He had been made a prebend of Lincoln cathedral five years before. The Rev. **F. H. Sutton** had an admirable knowledge of ecclesiastical art, of which he may be said to have seen and remembered all that is best. His knowledge of that branch of art was of more service to others through the hints which he readily gave to them in their work, than in any written or wrought production of his own. Many are the professional and amateur workers that have profited by his advice and taste. His own direct work was confined chiefly to a small book on an ancient organ,‡ the execution of some painted glass in Ketton church and Lincoln cathedral,§ and the superintendence of the perfect restoration and adornment of the church at Brant-Broughton. There he will long be remembered as one of the best of parish

* *Genl. Mag.* Vol. v., p. 681. † *Nichols*, Vol. ii., p. 828. Inscription gives his age as 54. ‡ Some account of the mediæval organ at old Radnor. § These were painted by him and his brother the Rev. Prebendary Augustus Sutton.

priests, for it is well known that his devotion to ecclesiastical art was subsidiary to higher things.*

The arms of **Sutton** are; *Argent a canton Sable; Crest; a wolf's head erased Gules.*

WELHAM.

SILVER CUP WITH COVER PATEN. Weight of cup 6.4 oz. Height 6 in. Diam. of bowl $3\frac{3}{4}$ in.; of foot $3\frac{5}{8}$ in. Height of stem $2\frac{5}{8}$ in. Date *circa* 1575. (PLATE 14.)

Only one mark, a rose.

The bowl of this cup which is an inverted truncated cone, with a flat projecting base, has a band of foliage divided in 4 parts by large hour-glass curves, each of these parts being divided in half by smaller curves. The stem, which has no knob, has round its upper and lower edges, the reed ornament roughly done. The foot is of the usual shape and somewhat rudely made like the rest of the cup; a narrow reed ornament runs round its edge.

SILVER COVER PATEN with a foot. Weight 3 oz. Diam. $4\frac{1}{4}$ in. Diam. of foot $2\frac{1}{2}$ in. Height of foot $\frac{7}{8}$ in. Date *circa* 1575. (PLATE 14.)

No marks.

This paten has a narrow flat edge from which the middle part is sunk flat. It has no rim inside. The foot is a disk attached to the paten by a conical stem.

In addition to these two pieces, a pewter flagon belonged to this church in 1709. This was not here in 1832.

* The *Guardian*, March 14, 1888.

“‘*Et, Launcelot,*’ said she, . . . ‘anon there appeared the Sangreel unto the white knights, but thou was so feeble of good belief and faith, that thou might not abide it, for all the teaching of the good man, but anon thou turnedst unto the sinners; and that caused thy misadventure.’”

GARTREE SECOND DEANERY.

BURTON OVERY.
 CARLTON CURLIEU.
 ILSTON-ON-THE-HILL.
 EVINGTON.
 FLECKNEY.
 GAULBY.
 GLENN MAGNA.
 STRETTON MAGNA.

HOUGHTON-ON-THE-
 HILL.
 KIBWORTH.
 KILBY.
 KING'S NORTON.
 STRETTON PARVA.
 NOSELY.
 SADDINGTON.

SCRAPTOFT.
 SHANGTON.
 SMEETON WESTERBY.
 THURNBY.
 STOUGHTON.
 WISTOW.
 NEWTON HARCOURT.

BURTON OVERY.

SILVER CUP. Weight 13.2 oz. Height 8 in. Diam. of bowl $3\frac{7}{8}$ in.; of foot $3\frac{3}{4}$ in. Height of stem 4 in. Date 1777.

Hall marks. 1. Small Roman B in square shield. 2. Leopard's head crowned in a rounded shield. 3. Lion passant in an oblong. 4. Capital Old English W in an oblong.

The bowl of this cup is straight-sided in shape, rounded underneath, having a bell-shaped lip. It has a baluster stem. On the bowl is the sacred monogram, with a cross above, and three nails below, within a circle of glory; beneath is "*Burton Overy, 1777.*"

SILVER PATEN with foot. Weight 4.5 oz. Diam. 5 in. Diam. of foot 2 in. Height of foot 1 in. Date 1777.

Hall marks as on the cup.

This paten is quite plain in shape; having in the centre the sacred monogram, with "*Burton Overy, 1777,*" below.

SILVER ALMS BASIN. Weight 9.5 oz. Diam. $8\frac{3}{4}$ in. Depth $\frac{7}{8}$ in. Date 1777.

Hall marks. 1, 2, and 3, as on the cup. 4. T. D. in an oblong; the mark of *Thomas Daniell*.

In the centre of the basin is the sacred monogram, with "*Burton Overy, 1777,*" below.

SILVER DISH. Weight 6.4 oz. Diam. $7\frac{1}{8}$ in. Date 1852.

Sheffield hall marks.

This dish is plain and flat in shape, the middle of it being sunk in a six-lobed depression.

SILVER PLATED FLAGON. Height $10\frac{5}{8}$ in. Diam. of the top $4\frac{1}{2}$ in.; of foot 7 in.

This flagon is straight-sided in shape with a spout at the top, having the sacred monogram with a cross and three nails in a circle of glory, in front.

TWO PEWTER ALMS BASINS. Diam. $9\frac{1}{2}$ in. Depth of each 1 in.

Marks. 1. X crowned. 2. "Refined metal." 3. A lion passant with the sun in splendour above, between "**John Boteler.**" 4. "**Boteler.** London." 5. T. T. E.

Upon the cover of Vol. iii. of the parish registers of Burton Overy this entry was made on Christmas Day, 1777, by the Rev. **Samuel Topp**, rector; "Dec. 23rd, 1777, **John Weston**, Esquire, of Hatton street, London, gave to the parish of Burton Overy a silver chalice and paten, for the purpose of administering the bread and wine at the Holy Communion, and the parish having sent up to him the old silver chalice to change, which was insufficient, for the purchase of a silver plate for the collection of the alms at the Lord's Supper, the said **John Weston**, Esq^{re}. made up the deficiency, and sent the silver plate for the alms together with the chalice and paten for the use of the parish."

John Weston sprang from an old yeoman family of Burton Overy,* members of which are named in many entries in the parish register. He was not however born here, but in London where his father had settled. He was the son of **Richard** and **Catherine Weston**, and was baptized at St. James', Clerkenwell, on 19th April, 1724.† He lived for some years in St. John street, Clerkenwell, and then in Hatton street, St. Andrew's, Holborn. Having evidently prospered in his worldly affairs, he died in Hatton Street, and was buried in St. James', Clerkenwell, on 4th Jan., 1786, aged 61.† **John Weston** married at Tugby, co. Leicester, in 1751,‡ **Elizabeth**, daughter of the Rev. **Joseph Peppin**, vicar of Tugby, and **Frances**, dau. of **Edward Brudenell**, Esq., of Barton Seagrave, Northants, which lady was buried in St. James', Clerkenwell, on 19th Dec., 1761, aged 36;† having borne Mr. **Weston**, a daughter, **Frances Brudenell**, baptized at St. James', Clerkenwell, on 20th Oct., 1753.†

By his will, made 5th Feb., 1783, and proved P.C.C., 11th Jan. 1786, **John Weston** "of Hatton street, Esq.," left to Rev. **William Morice**, D.D., of Hatton street, and **John Ham** the elder of Spital square, all his freehold property in 5 Inkhorn court, Petticoat lane, in Boar's Head yard, Petticoat lane, with Meeting house in Boar's Head yard; also six leasehold tenements in St. John street and Sutton street, St. James', Clerkenwell; also leasehold premises in Old Nicoll street in St. Matthew's, Bethnal Green, and all other leasehold property held under the Duke of Chandos, in trust for the benefit of his daughter **Frances Brudenell**, "independently of any husband she may marry." To his brother the Rev. **Thomas Weston**,§ of Halesworth, Suffolk, Clerk, £100. To poor of Burton Overy and Tugby £5 each. To S.P.G. £5. Daughter, **Frances Brudenell**, residuary legatee and sole executrix.

The modern silver dish and silver plated flagon were given by some of the parishioners of Burton Overy.

* One of whom was Hugh Weston, Dean of Windsor, 1556. *Nichols*, Vol. ii., p. 537. † Parish Register. ‡ Parish Register. § Baptized at St. James', Clerkenwell, on 29th Nov. 1730, Born 22nd Nov.

CARLTON CURLIEU OR WEST CARLTON.

SILVER CUP. Weight 14 oz. Height 9½ in. Diam. of bowl 4¾ in.; of foot 4 in. Height of stem 4 in. Date 1686. (PLATE 16.)

Hall marks. 1. Small black letter I in plain shield. 2. Lion passant in oblong. 3. Leopard's head crowned, in a circle. 4. R.C. three pellets above and below, within a dotted circle.

The bowl of this cup is straight-sided in shape with a bell-shaped lip. The stem is plain and thick, with a small round moulding on a narrow fillet for a knob, from whence it swells out to the bowl and into the foot, which is quite plain in shape. Underneath the foot is; "*For West Cavellon Church in Leicestershire. Given by Frances Grantham, widow, mother to Mr. Palmer, and daughter of Sr. Georg Wentworth, of Wolley in York Shire.*" On the side of the bowl within a lozenge, is this coat of arms: *Ermine, a griffin segreant Gules; Grantham; impaling, Sable, a chevron between three leopards' faces Or; Wentworth.* The annual letter is repeated underneath the foot.

SILVER PATEN with foot. Weight 6.2 oz. Diam. 5¾ in. Diam. of foot 2½ in. Height of foot 1½ in. Date 1686. (PLATE 16.)

Hall marks as on the cup.

This paten, which fits on to the cup with the foot downwards, has a flat edge, from whence the middle part is slightly sunk. Underneath the foot there is the sacred monogram with a cross above and a heart below within a circle of glory.

PEWTER FLAGON. Height 12 in.

Marks. 1. X crowned. 2. Lion passant repeated three times. 3. H.G.

PEWTER DISH. Diam. 9¼ in.

Marks. 1. X crowned. 2. An eagle rising out of a ducal coronet towards the sun in splendour; repeated twice. 3. V. and W. 4. "Birmingham."

Frances Grantham was the second daughter and co-heir of Sir **George Wentworth**, Knt., of Woolley, and Notton, co. York,* by his second wife, **Everild**, second daughter and co-heir of **Christopher Maltby**, of Maltby, co. York. She married close to 1559, **Thomas Grantham**, of Goltho, co. Lincoln, and Meux Abbey, co. York, the representative of an ancient Lincolnshire family, who obtained his Yorkshire estate through his mother, **Dorothy**, third daughter and co-heir of Sir **William Alford**, of Meux.† **Thomas Grantham**, and his wife, **Frances**, seem to have lived a good deal at Fixby, co. York, the seat of their brother-in-law, **John Thornhill**, who married **Everilde**, eldest daughter of Sir **George Wentworth**: here they were within reach of Woolley, and also of Farsley, **Frances Grantham's** share of her father's estates. At Fixby **Thomas Grantham** died on 1st April, 1668, aged 34, and was buried in Elland church on the 3rd.‡

* His only son Michael died in his father's life-time, leaving a widow, Katherine. † For pedigree see *Miscell. Genea. & Herald.* Vol. i., 2nd series, p. 204. ‡ Parish Register.

By his will, made 30th March, 1668, and proved in the Prerogative Court, York, on 5th May following, **Thomas Grantham**, "of Meux," left the lordship of Goltho to his son **Vincent**, subject to the payment out of it of £1600 to his daughter **Dorothy**, and £1500 to his daughter **Elizabeth**; the said lordship to go to his brother **Vincent**, if his son **Vincent**, dies without heirs: To his mother **Dorothy Grantham**, ten pieces of guinea gold for a ring: To his brother **Francis**, an annuity of £20 charged upon the lordship of Wragby, co. Lincoln, if his son **Vincent** dies without issue before he is 21: To his wife **Frances**, the government of all his estates until his son comes of age; she sole executrix.

Vincent, only son of **Thomas** and **Frances Grantham**, died at the age of 12, and was buried in Elland church on 5th April, 1674;* consequently his two sisters became their father's co-heirs. The eldest† **Dorothy**, married **James Holt**, Esq., of Castleton, Lancashire, and eventually obtained the estate of Meux: the second, **Elizabeth**, married Sir **Geoffrey Palmer**, 3rd Bart., of East Carlton Park, co. Northants, and Carlton Curlieu, and inherited her father's estate at Wragby. This lady and her husband spent most of their married life at Carlton Curlieu, living in the charming old hall here,‡ that had been bought and enlarged by Sir **Geoffrey Palmer**, 1st Bart., attorney-general to King **Charles II.**; over the porch of which are the arms of **Palmer**; *Sable, a chevron Or, between three crescents Argent; impaling Grantham*. Crest: *a wyvern Or armed and langued Gules*. (FIG. 22.) Here no doubt Mrs. **Grantham** often visited her son and daughter. She died at the house of her eldest daughter, **Dorothy Holt**, at Castleton, on 12th March, 1692-3, and was buried next her husband in Elland church.*



Fig. 22.

By her will, made 28th May, 1692, and proved in the Prerogative Court, York, on 17th June 1693, **Frances Grantham**, left to her sister **Thornhill**, of the city of York, widow, all her share in the estates at Wadlings and Farseley, co. York, after the death of Lady **Kaye**, "now wife of **Henry Sandys**, of Downe, Kent," left to her by her father, Sir **G. Wentworth**, together with a sum of £500 charged on Meux, and all personalty, in trust, for the use of testator's two daughters equally, when they become widows: the said estates if the daughters leave no children, to pass to testator's nephews, Sir **Richard Osbaldeston**, of Humanby, Knt.,§ and **Bryan Thornhill**, of Fixby. In a codicil, she left; £52 to the poor of Elland and Fixby, the interest to be spent on Christmas Day as follows; 1s. each to 20 poor men, and as many poor women, and 12 poor boys: To the poor of Rochdale and Castleton £30; the interest, 30s., to be spent on Christmas Day, as "son **Holt** and daughter," shall think fit: To the poor of Wragby £20; the interest, 20s., to be given away on Christmas Day. Her sister, **Everild Thornhill**, sole executrix. Seal; "Wentworth," single on a lozenge, a crescent for difference.

In Elland church is a square marble monument, commemorating

* Parish Register. † There seems to have been an elder daughter, **Frances**, who must have died early. She was left an annuity of £5 by her grandfather Sir **G. Wentworth**, in his will proved at York 30th Oct. 1660.
‡ Rented from Sir **Geoffrey Palmer**, Bart. until recently, by my good friends and former neighbours Mr. and Mrs. **Francis E. Bigge**. § Son of Will. **Osbaldeston** and Anne third daughter of Sir **G. Wentworth**.

members of the **Thornhill** family, and also **Thomas, Frances, and Vincent Grantham**; this was moved from the chancel to the North wall of the nave some few years ago during a church restoration.*

ILSTON-ON-THE-HILL.

SILVER CUP. Weight 13.4 oz. Height 8 $\frac{3}{8}$ in. Diam. of bowl 3 $\frac{3}{8}$ in.; of foot 3 $\frac{3}{8}$ in. Height of stem 4 $\frac{1}{4}$ in. Date 1758. (PLATE 16.)

Hall marks. 1. Capital old English C in square shield. 2. Leopard's head crowned in rounded shield. 3. Lion passant in oblong. I. P. in script letters, a pellet between, in a shaped oblong; the mark of *John Payne*.

This cup has a straight-sided concave bowl, a plain round stem with a small moulding for a knob, and a raised foot with mouldings round its edge. In front of the bowl is this coat of arms: *Argent, a chevron between three hazel leaves Vert; Hazlerigg.*

SILVER PATEN with a foot. Weight 5.1 oz. Diam. 4 $\frac{1}{2}$ in. Height of foot 1 in. Diam. of foot 2 $\frac{3}{8}$ in. Date 1758. (PLATE 16.)

Hall marks as on the cup.

This plain paten fits loosely on to the cup both as a cover and also when placed on it with the foot downwards. In its centre are the donor's arms as on the cup.

SILVER DISH. Weight 12.1 oz. Diam. 8 $\frac{3}{4}$ in. Date 1759. (PLATE 16.)

Hall marks. 1. Capital old English D. 2, 3, and 4 as on cup.

There is the same coat of arms in the centre of this dish which is quite plain in shape, having a small moulding running round its edge.

SILVER FLAGON. Weight 32.9 oz. Height 10 in. Diam. at top 3 $\frac{1}{2}$ in.; of foot 6 $\frac{1}{4}$ in. Date 1759. (PLATE 16.)

Hall marks as on the dish.

This flagon is straight-sided in shape narrowing towards the top. It has a round top to its lid, a large plain handle and open purchase. In front, underneath the **Hazlerigg** coat of arms, is this inscription in Roman characters; "*This communion plate the gift of Sir Arthur Hesilrige,† Bart., to the parish church of Ilston-on-the-Hill in the county of Leicester 1759.*" This service is a very good example of church plate made in the middle of the last century. It is kept in an oak box, made at the same time as the plate, which has two different locks to it; the original intention being that each churchwarden should keep a key, so that the box could not be opened without the consent of both.

Sir Arthur was the only son of Sir Robert Hesilrige, Bart., by Dorothy, the second daughter of Banaster, Lord Maynard, and was born in 1705. He succeeded his father as 7th Bart. in 1721, and married four years later Hannah, the daughter of Mr. Sturges. It was from this lady that Richardson drew his character of "Pamela."‡ Sir Arthur rebuilt the greater part of the house at Nosely, making it what it now is; he also

* For inscription see *Yorkshire Archaeol. Journal*. Vol. x., p. 111. † One of the many different ways in which the name of this family was formerly spelt. The word "is" was probably omitted by the mistake of the engraver. ‡ See *Nichols*, Vol. xiv., p. 749.

bought back certain lands there, which had formerly been in the possession of his family. The oak reredos in Nosely chapel was erected by him, and also some oak panelled pews; but these have since been cut down and made into open seats. Though Sir **Arthur Hesilrige** did so much to improve the ancient inheritance of his family at Nosely he did not reside there much, but lived chiefly in Northampton, in which town and county his family had for some time owned property. He was high sheriff of that county in 1726, and died at Northampton on 23rd March, 1763; Lady **Hesilrige** dying there also on 27th Feb. 1765. They were both buried at Nosely, a mural oval tablet of marble being placed to their memory upon the North side of the chapel, surmounted by the arms of **Hazlerigg**; *Impaling; Azure a chevron between three cross crosslets fitchée Or*; **Sturges**. Sir **Arthur Hesilrige** and his lady were the great-grandparents of the present much esteemed owner of Nosely, Sir **Arthur Hazlerigg**, 12th Bart.

EVINGTON.

SILVER CUP. Weight 9 oz. Height $7\frac{1}{4}$ in. Diam. of bowl $3\frac{3}{8}$ in.; of foot $3\frac{1}{4}$ in. Height of stem $2\frac{3}{8}$ in. Date 1632. (PLATE 16.)

Hall marks. 1. Italic P in a plain pointed shield. 2. Lion passant. 3. Leopard's head crowned; each of these two latter having an outside line following its outline. 4. W. N. with a pellet between the letters and a cinquefoil below, within a shaped shield. The W is very indistinct.

This cup has a deep straight-sided bowl swelling out a little at the lip. Its stem is short and evenly balanced, having a plain round knob in the middle. Some lines and small mouldings run round the edge of the foot, underneath which the lion passant is repeated. In front of the bowl within a laurel wreath is "Evington 1632:" the whole design being engraved in dotted lines. The bowl has been recently gilt inside.

SILVER PATEN with a foot. Weight 4.3 oz. Diam. 5 in. Diam. of foot $2\frac{3}{8}$ in. Height of foot 1 in. Date 1632. (PLATE 16.)

No hall marks.

This paten has a flat edge $\frac{3}{8}$ of an inch wide, the part within being sunk flat to the depth of $\frac{1}{8}$ of an inch. Its foot is a disk attached to the paten by a plain round stem swelling out at both ends.

This paten fits on to the cup with its foot downwards, and was to all appearance made at the same time.

SILVER DISH. Weight 5.9 oz. Diam. $6\frac{1}{2}$ in. Date 1740.

Hall marks. 1. Small Roman E in a shaped shield. 2. Leopard's head crowned in a shaped shield. 3. Lion passant in a shaped oblong. 4. F. S. a pellet between the letters and a crown above, within a shaped stamp, the mark of *Francis Spilsbury*.

This dish is quite plain in shape, having a small moulding round its edge. Underneath is "*The gift of Mrs. Jane Tompson, widow, late of this parish, and daughter of Mr. Ben^r. Billers late of St. Margaret's Parish, Leicester, 1740.*"

SILVER DISH. Weight 5.7 oz.

In all other respects exactly like the first.

SILVER PLATED FLAGON. Height 13½ in. Diam. at top 3¼ in. ; at foot 6½ in. This is a straight-sided flagon narrowing towards the top.

In 1632 the lord of the manor of Evington and sole freeholder was **William Cavendish**, 3rd Earl of Devonshire.

The two little dishes were bought in accordance with this clause in the donor's will, made 23rd Oct., 1734, and proved at Leicester with a codicil dated 1st July, 1735, on 14th Oct., 1737: "*I give £5 to be laid out in a clock or silver salver at the election of the Vicar and inhabitants of Evington aforesaid for the use of the church there.*" This lady was **Jane**, the second daughter of Mr. **Benjamin Billers**, of the Bishop's Fee, Leicester, by his wife **Jane**, daughter of **George Allen**, of Dingley, Northants, and was born in 1660; her father being a younger brother of **Edward Billers**, she was first cousin to Mrs. **Barnes**, the donor of the flagons to St. Martin's, Leicester.* **Jane Billers** married circa 1688 Mr. **James Tompson**, of Evington, to whom she bore two daughters, **Jane** and **Elizabeth**, who both died unmarried in Nov., 1718, and were buried in the nave of St. Margaret's, Leicester. **James Tompson** died circa 1714.† His widow continued to live at Evington, and died there, leaving no surviving issue; she was buried in St. Margaret's, Leicester, on 9th March, 1735-6.‡ No monument was placed to either her or her husband's memory.

Mrs. **Tompson**§ left £5 to the poor of St. Margaret's, and £2 to the poor of Evington. Most of her personalty and all her lands in Glenfield, Leicester Forest and the Bishop's Fee, she left in equal shares to her younger sister **Elizabeth**, widow of **George Coulton** of Evington, and to her niece **Jane Alfounder** the daughter of her elder sister, whom she appointed her executors. Legacies were left to her nephew Rev. **Robert Alfounder**, niece **Mary**, wife of **Richard Hill**, and their children **Richard** and **Mary**, niece **Mary**, wife of **Edward Hooke**, cousin **Thomas Ludlam** the elder, godson **Robert Coulton**. Seal, a lion rampant, representing probably the arms of **Billers**; per pale Gules and Sable a lion rampant Argent. The arms of **Tompson** as cut on the monument formerly in St. Margaret's church, to this lady's two daughters, are a lion passant guardant.¶

It will be noticed that there was a delay in proving the will, and afterwards a further delay before Mrs. **Tompson's** bequest was carried out.

The silver plated flagon was bought about twelve years ago by the parishioners.

FLECKNEY.

SILVER CUP AND COVER PATEN. Weight of cup 5.9 oz. Height 6½ in. Diam. of bowl 3½ in. ; of foot 3¼ in. Height of stem 2⅔ in. Date 1567. (PLATE 15.)

* Page 91. † Inventory dated 1714. ‡ Parish Register. § Spelt Tomson in will. See also p. 83. ¶ See *Nichols*, Vol. i., p. 563, where the name is misspelt. For pedigree of **Billers**, *ibid.* Vol. iii., p. 188.

Hall marks. 1. Small black letter K with an annulet below, in a plain shield. 2. Lion passant. 3. Leopard's head crowned, each of these two latter having an outside line following its outline. 4. I R with a mullet having square ends above, within an ornamental shape; both these letters are indistinct.

The bowl of this cup is narrow and deep in proportion to its stem, and is nearly straight-sided in the lower part, gradually swelling out into a bell-shaped lip. Round its middle is a band of foliage, divided into three parts by hour-glass curves. The stem and foot are of much the usual shape, the egg and tongue ornament running round the edge of the latter.

SILVER COVER PATEN with a foot. Weight 2.4 oz. Diam. 4 in. Diam. of foot $1\frac{3}{8}$ in. Height of foot $\frac{3}{4}$ in. Date 1567. (PLATE 15.)

Hall marks the same as those on the cup with the exception of the maker's mark being omitted.

This cover paten is quite plain in shape with the usual rim inside. It fits on to the cup both ways.

SILVER PATEN with a foot. Weight 5.1 oz. Diam. $5\frac{3}{8}$ in. Diam. of foot 2 in. Height of foot $1\frac{1}{8}$ in. Date 1863.

London hall marks.

This paten is perfectly plain, having in its centre the sacred monogram with a cross above and three nails below within a circle of glory.

SILVER FLAGON. Weight 16.6 oz. Height $7\frac{1}{4}$ in. Diam. at the top $3\frac{1}{2}$ in.; at the foot 5 in. Date 1772.

Hall marks. 1. Capital old English R in a square shield. 2. Leopard's head crowned in a rounded shield. 3. Lion passant in a plain oblong. 4. I D with a pellet between, in a plain oblong. Mark perhaps of *John Darwall*.*

This is a good solid little flagon, straight-sided in shape, narrowing slightly towards the top. It has a plain round handle, a spout at the top and a flat lid rounded off. On its side is engraved the sacred monogram, with a cross above and three nails below, within a circle of glory.

PEWTER PATEN. Diam. 6 in.

This paten has been silver-plated on its upper surface, which is engraved. It has three feet below.

The flagon and modern silver paten were bought by the communicants of Fleckney in 1863, during the incumbency of the Rev. **Thomas Badcock**, vicar of this parish from 1854 to 1883, and now rector of Walgrave, co. Northants. The plated paten was bought for temporary use a few years previously.

GAULBY.

SILVER CUP. Weight 7.5 oz. Height $6\frac{3}{8}$ in. Diam. of bowl $3\frac{1}{4}$ in.; of foot $3\frac{1}{8}$ in. Height of stem $2\frac{1}{8}$ in. Date 1717. (PLATE 15.)

* *Gilda Aurifabrorum*. W. Chaffers, p. 189.

Hall marks. 1. Capital Roman B in a plain shield. 2. Britannia. 3. Lion's head erased. 4. S.P., a pellet between the letters, two pellets above and a bird below, within a shaped shield. Mark of *William Spackman*.

The bowl of this cup is in shape an inverted truncated cone rounded off below, resting on a baluster stem and plain foot, with the lion's head erased repeated underneath. On the bowl is; "*Wm. Bird, Tho. Billing, Churchwardens, 1717, Gaulby.*"

SILVER FLAGON. Weight 26 oz. Height $6\frac{3}{8}$ in. Diam. of top $4\frac{3}{4}$ in.; of foot $5\frac{1}{4}$ in. Date 1701. (PLATE 16.)

Hall marks. 1. Court hand F in plain shield. 2. Lion's head erased. 3. Britannia. 4. P. o., with two pellets above and two below, within an oval.

This is a short, wide, and straight-sided tankard, with an ornamental purchase, and a flat lid with its rim shaped in front into a point. In front of the drum is; "*The gift of Isabel Goosey, Virgin, to the church of Galby, 1701.*"

PEWTER PLATE. Diam. $9\frac{3}{4}$ in.

Marks. 1. X crowned. 2. Four small marks, the first being a leopard's face; the other three are indistinct.

This plate which is used as a paten has a raised edge one inch wide, on which is "*Galby Communion plate.*"

Money for the purchase of the flagon was bequeathed by **Isabel Goosey**, in her will, dated 18th July, 1700, and proved at Leicester, with these words; "*I give and bequeath to the church of Galby £8 to buy a silver flagon or some such convenient vessel for the blessed Sacrament for ever.*" She died unmarried upon 11th Jan., 1701, at the age of 71: and was buried in Gaulby churchyard, a small headstone still existing over her grave.

In addition to the above bequest, **Isabel Goosey** left £1 to the poor of Norton, and the same sum to the poor of Gaulby.

GLENN MAGNA.

(a)

SILVER CUP. Weight 10.4 oz. Height $8\frac{3}{8}$ in. Diam. of bowl and of foot $3\frac{3}{8}$ in. Height of stem 4 in. Date 1760.

Hall marks. 1. Capital Old English E in square shield. 2. Leopard's head crowned in rounded shield. 3. Lion passant in plain oblong. 4. F.W. in script letters within an oblong. The mark of *Fuller White*.

The bowl of this cup is straight-sided, with a bell-shaped lip. The stem is narrow and quite plain in shape, with a small flat moulding for a knob. In front of the bowl is; "*The gift of Mrs. Ann Hewett. Ob. 5 Apr. 1760. Æt. 56.*"

SILVER PATEN with a foot. Weight 4.8 oz. Diam. $4\frac{7}{8}$ in. Diam. of foot 2 in. Height of foot $\frac{7}{8}$ in. Date 1760.

Hall marks as on the cup.

This paten fits on to the cup as a cover, the centre being sunk, leaving a raised edge. Upon the foot underneath is the same inscription as on the cup.

SILVER FLAGON. Weight 38.4 oz. Height 12¼ in. Diam. of top 4¼ in.; of foot 7½ in. Date 1760.

Hall marks as on the cup.

This flagon is straight-sided in shape, narrowing towards the top. It has a wide foot, a plain round handle, and a round top to its lid. In front is the same inscription as that on the cup.

(b)

SILVER DISH. Weight 8.9 oz. Diam. 8 in. Date 1826.

London hall marks.

This dish is quite plain; it has the sacred monogram in the centre, and a raised moulding round the edge.

(c)

SILVER CUP. Weight 11.6 oz. Height 8 in. Diam. of bowl 4 in.; of foot 5½ in. Height of stem 5½ in. Date 1876.

London hall marks.

The bowl of this cup is an inverted cone rounded off below. The knob and foot are hexagonal in shape.

(d)

Though not exactly a piece of church plate, a large silver two-handled cup with a cover may well be mentioned here. This is an urn-shaped cup, and is in height, with the cover on, 18⅝ in. The diam. of the top is 7½ in.; and of the foot 5⅝ in. Date 1835.

London hall marks.

The cover is surmounted with a figure of St. Cuthbert, the patron saint of this church, holding his pastoral staff in his left hand, the head of King Oswald in his right. In front of the cup is "*This cup was given by the Rev^d. Henry Luke Dodds, to the church in Great Glenn, to be used for the Loving Cup at the feast of the dedication. A.D. 1859.*"

(a)

The following extract from the will of **Anne Hewett**, dated 4th March, 1760, and proved in Leicester, accounts for the first three pieces of plate; "*I give and bequeath the sum of £20 to be laid out on communion plate for the use of the church of Great Glenn.*" **Anne Hewett** was the youngest daughter of **George Hewett**, of Glenn Magna and Stretton Magna, by **Penelope** his wife, the second daughter of Sir **William Jesson**, Knt., of Coventry, and of Burleigh Park, Loughborough, and co-heir to her uncle Sir **William Villiers**, of Brooksby, last Bart.

The **Hewetts**, who were originally a Dunton Bassett family, obtained property in this parish through the marriage of **William Hewett**, great grandfather of **Anne**, with **Frances** the daughter of **Edward Nele**. One member of this family built Great Stretton Hall, now the property of **C. Packe**, Esq. **Anne Hewett**, whose name by the bye, is not mentioned in the pedigree given by *Nichols*, (Vol. 2, p. 581,) resided at Melton Mowbray, to be the churchwardens and overseers of which parish she bequeathed £20 to be

expended in coal every summer and sold at the same rate each winter to the poor of that place. To the poor of Glenn she left £5. She died unmarried on 5th April, 1760, aged 56, and was buried in the chancel of Glenn church, next her parents, in accordance with the wish expressed in her will; no memorial, however, was placed over her grave; but there was formerly hanging in this church a list of benefactions, on which her bequest was recorded, but not correctly, the sum being named as £50. The arms of **Hewett** are: *Sable a chevron between three owls Argent. Crest: An owl proper.*

(b)

Nothing certain is known about the origin of the silver dish.

(c)

The modern silver cup was presented to this church by a few friends of the late vicar's, the Rev. **H. L. Dodds**.

(d)

The Rev. **Henry Luke Dodds**, M.A., the donor of the large two-handled cup to the church in this parish, was the only son of **Luke Dodds**, Esq., of Woodford, Essex, and was born in 1811. Having graduated from Christ Church, Oxford, he received deacon's orders in 1838, and was appointed to the curacy of Freshwater, I.W. In 1855 he was presented to the vicarage of Glenn Magna and Stretton, which he retained till his death on 10th May, 1886. Mr. **Dodds**, who was unmarried, was known amongst his parishioners and neighbours as one of the most generous of men, the last person of whom he took any thought being himself. His wish, in presenting this covered cup, was, that the churchmen of Glenn should meet on St. Cuthbert's Day, 4th Sep., and keep the dedication day of their church as a village festival, first taking part in a thanksgiving service in church, and then sitting down together to a feast, at which this gift of his should be used as a loving cup.

STRETTON MAGNA.

SILVER PLATED CUP. Height 6 $\frac{3}{8}$ in. Diam. of bowl 3 $\frac{3}{8}$ in.; of foot 2 $\frac{1}{2}$ in. Height of stem 2 $\frac{1}{2}$ in.

This is a plain-shaped little cup, having a straight-sided bowl and a plain narrow stem. Upon the bowl is engraved the sacred monogram within a circle of glory.

SILVER PLATED PATEN. Diam. 7 $\frac{3}{4}$ in.

This is a plain round plate, having in its centre the sacred monogram within a circle of glory.

PEWTER FLAGON. Height 12 in. Diam. at the top 3 $\frac{3}{8}$ in. Diam. at the foot 6 in.

This is a straight-sided flagon of modern make, narrowing a little towards the top.

Archdeacon **Bonney** does not mention any communion plate in his inventory of the church goods of this parish.

This service was given, until something better could be procured, by Col. **John King**, J.P. and D.L. for this county, who at one time resided at Stretton Hall. This gentleman was lord of the manor of Ilston-on-the-Hill, having inherited from his relative, Miss **Mary Heard**, the manor-house and land in that parish which once belonged to the **Nedhams**. He was Lieut.-Col. of the Leicestershire Militia, in which regiment he had held a commission for 59 years. Col. **King** died on 27th July, 1869, aged 82. By his wife **Mary**, who died on 4th Oct., 1863, aged 76, he had three daughters, the present ladies of the manor of Ilston, one of whom is Mrs. **Corrance**, of Syston, her two unmarried sisters residing at Thurnby.

HOUGHTON-ON-THE-HILL.

SILVER CUP. Weight 5 oz. Height $6\frac{3}{8}$ in. Diam. of bowl and of foot $3\frac{1}{4}$ in. Height of stem $3\frac{1}{8}$ in. Date *circa* 1570.

No hall marks.

The bowl of this cup is in shape an inverted truncated cone, slightly bell-shaped. It has a band of Elizabethan stroke ornament round its middle, divided into six parts by hour-glass curves. The stem is modern, and quite plain and straight in shape, being simply a cylinder with a small moulding round the middle for a knob. The foot is the one that has always belonged to the cup, and is of the usual Elizabethan shape, with three or four horizontal lines drawn round its edge. The original stem was taken out about thirty years ago, and the present one put in, in order that this cup might stand as high as the one mentioned below.

(a)

SILVER CUP. Weight 8.4 oz. Height $6\frac{3}{8}$ in. Diam. of bowl $3\frac{1}{8}$ in.; of foot $3\frac{1}{4}$ in. Height of stem $3\frac{1}{4}$ in. Date 1636. (PLATE 15.)

Hall marks. 1. Small italic T in a plain shield. 2. Lion passant. 3. Leopard's head crowned, each of these two marks having an outside line following its outline. 4. I. H., with two pellets above and two below, within a shaped oblong.

This cup has a V-shaped bowl, baluster stem, and flat foot with its edge turned round inside. On the bowl is: "*Houghton. The gift of Joseph Birkhead, Rector, 1683.*"

(b)

SILVER PATEN. Weight 3.4 oz. Diam. 5 in. Date 1855.

London hall marks.

This paten is quite plain in shape, with the sacred monogram within a circle of glory in the centre.

SILVER PLATED DISH. Diam. 9 in.

SILVER PLATED DISH. Diam. $8\frac{1}{8}$ in.

This dish was used as a paten before the silver one was given.

PEWTER FLAGON. Height 11½ in. Diam. of top 4 in.; of foot 5½ in.

Marks. 1. X crowned. 2. Old English C in a circle, and three other small indistinct marks.

This flagon is straight-sided in shape, narrowing a little towards the top. It has an R shaped handle, and a round top to its lid, which has a knob.

(a)

The donor of the second cup was the son of **John Birkhead**, maltster of Leicester, by his wife **Elizabeth**, and was baptized at All Saints' in that town on 9th Oct., 1636.* **Joseph Birkhead** took his M.A. degree from Magdalen College, Cambridge, in 1661, and was ordained deacon by the Bishop of **Lincoln**, on 7th Aug., 1662, and priest in St. Martin's, Leicester, on 10th Aug., 1668, he having meanwhile served the curacy of Welby, co. Leicester; on 28th Oct., 1678, he was instituted to the rectory of Houghton, on the presentation of **St. John Bennet**.†

The Rev. **Joseph Birkhead** died without issue, and was buried on the South side of the chancel of Houghton church on the 14th Oct., 1705.‡ His widow, **Anne**, the daughter of Mr. **Thomas Price**, was buried on the North side in 1713. A slab with a simple inscription§ is placed over the grave of each.

By his will dated 16th July, and proved in Leicester on 29th Nov., 1705, Mr. **Birkhead** left to his wife for life certain lands in Barlestone, Osbaston, Newbold Verdon, Houghton, and a house in All Saints' Leicester: after her death the land to go to nephew **John Pratt**; the house in Leicester to niece **Elizabeth Smith**. To nephew **John Pratt**, half part of Angel Inn in Leicester, subject to an annuity to testator's sister **Hannah Skrimpton**. Legacies to **John Needham**, son of **John Needham**, clerk: to niece **Jane Birkhead** and nephew **John Buxton**. To servant **Mary Abbott**, a house in Houghton for life and silver porringer. To **John Pratt**, a half-yard of land in Houghton, charged with the payment of 10s. a year each to the Hospitals of the Newarke, and St. John's Leicester. To his wife, a house and piece of land in Barlestone absolutely; she to be residuary legatee and sole executrix.

Anne, widow of **Joseph Birkhead**, by will dated 6th April, and proved in Leicester 2nd June, 1713, leaves legacies to **Mary**, daughter of nephew **John Needham**, clerk, deceased: sister **Skrimpton** and others. To niece **Elizabeth De la Fontaine**, widow, property in Barlestone, she to "dispose of the said message and lands according to my private directions given to her for that purpose." Legacy of £40 to same object. **Anne Needham**, sister of Mrs. **De la Fontaine**, to execute that trust if the latter predeceases testator. **Anne Needham** sole executrix. Will sealed with crest of **Price**: *Out of a mural coronet On a lion's face proper.*

It will be noticed that the communion cup given by Mr. **Birkhead**, was made in the year he was born. It was perhaps originally given to him at his baptism. Mr. **Birkhead** gave £10 to the poor of this parish, the interest from which they still have the benefit of.

* Parish Register. † Bishop of Lincoln's Registers. ‡ Parish Register. § *Nichols*, Vol. i., p. 614

(b)

The silver paten was presented by Mrs. **Freer**, the mother of the present rector. This lady was **Elizabeth Walker**, the daughter of Mr. **Thomas Wood**, of Leicester, and was born on the 23rd Dec., 1799. She married on the 23rd Dec., 1825, **William Freer**, Esq., solicitor, of Stoneygate, Leicester, and clerk of the peace for the county, and bore him an only son, **William Thomas**, the rector of this parish. Mr. **William Freer** died on the 2nd. Oct., 1873, and was buried at Houghton near to the donor of this paten, who died on the 21st Dec., 1869.*

KIBWORTH HARCOURT AND KIBWORTH BEAUCHAMP.

SILVER CUP. Weight 22.5 oz. Height $8\frac{3}{8}$ in. Diam. of bowl $3\frac{7}{8}$ in.; of foot 4 in. Height of stem 5 in. Date **1825**.

London hall marks.

The bowl of this cup is rather short in proportion to the stem, and is straight-sided in shape. The stem is thick and square-shaped, being formed of four small columns with a hollow moulding between each. Round the stem towards the top there is a wide moulding, serving the purpose of a knob, a similar moulding being placed round the bottom of the stem, at its junction with the foot. This latter is in the shape of a quatrefoil, rising up to the stem with a succession of mouldings one above the other. On the bowl is the sacred monogram, with a cross above and three nails below, within a circle of glory.

SILVER PATEN. Weight 8 oz. Diam. $7\frac{3}{4}$ in. Date **1825**.

London hall marks.

This paten is a quatrefoil in shape, having a wide raised moulding round its edge. The sacred monogram is in the centre.

SILVER DISH with foot. Weight 28.3 oz. Diam. $8\frac{3}{8}$ in. Diam. of foot $3\frac{1}{2}$ in. Height of foot $3\frac{5}{8}$ in. Date **1825**.

London hall marks.

This dish is a pentagon in shape, with a wide raised moulding round the edge, and the sacred monogram in the centre. The foot and stem have the same mouldings, and are of the same quatrefoil shape as the foot and stem of the cup.

SILVER FLAGON. Weight 64.4 oz. Height 13 in. Diam. of top $4\frac{1}{2}$ in.; of foot $6\frac{5}{8}$ in. Date **1825**.

London hall marks.

This flagon is perfectly straight-sided, its sides being in the shape of a quatrefoil, with a hollow moulding in each corner. The foot is of the same shape, and rises up to the drum by mouldings placed one above the other. The handle is shaped like a bundle of reeds bound together, terminating at each end in a vine leaf. In front is the sacred monogram. The lid is surmounted with a cross. Underneath the foot is: "*This set of communion plate is*

* For pedigree of Freer see *Leicestershire Pedigrees*, by W. G. D. Fletcher, p. 139.

presented to Kibworth church by the Rev. Thomas Thomas, B.D., of Kibworth Harcourt, Leicestershire, 1825."

In the terriers of 1724 and 1745 the church plate here is said to be: "A silver cup and salver weighing together about 30 oz., without inscription."

Kibworth is partly indebted for its service of communion plate to the good offices of the late Mr. **John Marriott**. At the time when Mr. **Thomas** was wishing to make a gift to the church and was in doubt as to what it should be, Mr. **Marriott** advised him to present this gift of plate. The donor of it was the son of **George Thomas**, and was born at Gorwyn Castle, near Trelech, Carmarthenshire, on the 19th Nov., 1741, and was baptized at Trelech on the 24th. He was ordained deacon by the Bishop of **Hereford** on the 23rd Sep., 1764, and priest by the Bishop of **Llandaff** on the 29th June, 1766. His first introduction to this neighbourhood seems to have been in 1774, when he was presented to the living of Isham, co. Northants, by **Thomas Rokeby, Esq.*** In 1788 he, in addition to that preferment, accepted the curacy of East Farndon, under the non-resident rector, Mr. **Brook**, head master of Coventry Grammar School; here he occupied a couple of rooms in the old manor-house when he paid his weekly visits to the parish. Not content with the care of these two parishes, Mr. **Thomas** actually served as curate to Kelmarsh from 1813 to 1814. The living of Isham and curacy of Farndon he held till his death, on 1st Dec., 1825; he was buried in Kibworth church; on the East wall of the North aisle of which is a plain marble tablet to the memory of his wife and himself. Mr. **Thomas** married in 1796 **Elizabeth**, the daughter of Mr. **George Foxton**, the owner of a good property in Kibworth, part of which was held under a lease from Merton College, Oxford; through this lady, who died without issue on the 2nd Sep., 1797, her father's property in this parish passed to her husband.

Here in the manor-house he resided from his marriage till his death; walking over to serve his curacy at Farndon, seven miles off, nearly up to the last, even after he was turned 84; but going only occasionally to Isham. And here he formed a good collection of books chiefly on antiquarian subjects of which he had considerable knowledge; these were somewhat hastily sold a few years ago on the death of his nephew and heir **Capt. Phillips**; whose widow Mrs. **Phillips** of Fernleigh, Leicester, possesses various account books kept by Mr. **Thomas** which show him to have been a liberal contributor to all parochial objects in any parish with which he was connected: one entry records a gift of £100 made by him in 1824 to St. David's College, Lampeter, then being founded.

The manufacturers of this service, were Messrs. **Green, Ward, Green, and Ward**, of 1, Ludgate Street, London. A few years ago, two letters written by that firm, one to the Rev. **James Beresford**, the then rector of this parish, and the other to the donor of the plate, were discovered in a bookseller's shop and placed in the chest with the documents of

* *Gent. Mag.*, Vol. xcvi., p. 92.

this parish. The first of these letters contains a bill for the plate; the second is an acknowledgment for the money received in payment thereof. The following is a copy of the bill.

“Sep^r. 13th 1825

A large gothic shaped and fluted service of communion plate, chased and finished in the best style of workmanship, viz :—

	oz.	dwts.	£	s.	d.
A large silver flagon.....	64	10	48	12	10
“ “ “ chalice	19	4*	17	6	0
“ “ “ salver	28	8	19	5	9
“ “ “ plate	8	1	4	10	0
Engraving on each of the above articles the glory, I.H.S., etc.			1	18	6
Engraving underneath the foot of the flagon an inscription				16	0
A wainscot case, partitioned and lined			2	18	0
Paid for matting and cording the case					3 0
					C ^r
By old silver salver and chalice, 19oz. at 5s.†			95	10	1
			4	15	0
					90 15 1”

Messrs. **Green, Ward, Green, and Ward**, conclude their letter to the rector, with these words; “It gratifies us to state, that altho’ each article is abundantly strong and heavy, yet the total amount is *considerably within our estimate.*”

KILBY.

SILVER CUP. Weight 10.2 oz. Diam. of the bowl $3\frac{1}{2}$ in.; of the foot $2\frac{3}{4}$ in. Height of stem $3\frac{1}{4}$ in. Date **1814**.

London hall marks.

This cup has something of an acorn-shaped bowl, its lower part being fluted. It has a narrow stem with a plain round knob and foot. On the bowl is the sacred monogram with a cross above and three nails below, within a circle of glory, and round the lip is “*Kilby church Janry 1st, 1815. The gift of Sir Henry Halford, Bart., of Wistow Hall.*”

SILVER PATEN with a foot. Weight 9.6 oz. Diam. 6 in. Diam. of the foot $3\frac{1}{4}$ in. Height of the foot 1 in. Date **1814**.

London hall marks.

This very solidly made paten is quite plain in shape. In its centre and also on its foot is the sacred monogram with the cross and nails, within a circle of glory. Underneath is the same inscription as that on the cup.

While Wistow church has communion plate given to it by the last baronet of the old line of **Halford**,† of Wistow, Kilby has these two pieces given by the first baronet of the new creation. The donor of them was **Henry**, the eldest son of **James Vaughan**, of Leicester, M.D., by **Hester**,

* This is an unaccountable mistake. After obtaining possession of the bill I carefully weighed the cup again. † Here apparently is another mistake unless the old cup had been changed between 1745 and 1825.

‡ *Vide* p. 225.

second daughter of Alderman **Smalley** of that town; he was born on 2nd Oct., 1765; he was distantly related through his mother, to Sir **Charles Halford**, Bart., of Wistow; **Hester Smalley's** mother being **Elizabeth**, youngest daughter of Sir **Richard Halford**, 5th Bart. **Henry Vaughan**, the eldest of five brothers who all rose to be distinguished men in their several callings, was educated at Rugby School, and Christ Church, Oxford, from whence he graduated as B.A. and M.A., in 1788, M.B. in 1790, M.D. in 1791. Destined for his father's profession, he went to Edinburgh to study medicine. In due time he began to practice as a physician in London, where he speedily rose to a high position in his profession, becoming at last the principal court physician and leading London doctor of his day; he was created a baronet by King **George III.**, on 27th Sept. 1809.

In addition to being at the head of his profession, Sir **Henry Vaughan** was distinguished as a courtier, politician, and man of letters; gaining a reputation in the latter calling by writing "*Oratio Harveiana habita*," 18 Oct., 1800: "*Account of the opening of the coffin of King Charles I.*," 1813: "*Essays and Orations read at the Royal College of Physicians*," 1831, and again in 1842: "*The deaths of some Eminent Persons of modern times*," 1835: "*Nuge Metrice*," 1842.

Upon the death of Lady **Denbigh**, widow of Sir **C. Halford**, Bart., in 1814, Sir **Henry Vaughan** succeeded to the Wistow estates, and took the name and arms* of **Halford**, in accordance with the will of his distant cousin Sir **Charles Halford**. In 1820 he was chosen president of the Royal College of Physicians, which post of honour he held till his death on 9th March, 1844. He was buried in Wistow church, on the North wall of which is a marble monument to his memory bearing an inscription in Latin,† with a sculptured panel below, representing a physician giving medicine to a sick man. Sir **Henry Halford** married on 31st March, 1796, **Elizabeth Barbara**, second daughter of **John**, 11th Lord St. **John**, of Bletsoe, by which lady, who died 17th June, 1833, aged 71, he had a son, Sir **Henry**, 2nd Bart., the father of Sir **Henry Halford**, 3rd Bart., and present owner of Wistow.

KING'S NORTON.

SILVER CUP WITH A COVER PATEN. Weight of cup 17.2 oz. Height 9 in. Diam. of bowl $4\frac{1}{2}$ in.; of foot $3\frac{3}{8}$ in. Height of stem $4\frac{1}{2}$ in. Date 1728. (PLATE 16.)

Hall marks. 1. Capital Roman N in a square pointed shield. 2. Leopard's head crowned in a rounded shield. 3. Lion passant in a plain oblong. 4. G.F.,‡ with a dove above within a trefoil.

* To which by royal warrant he received in 1837 an augmentation, *Burke's Baronetage*. † See *History of Market Harborough*, by J. H. Hill, F.S.A., p. 321. ‡ The F in the maker's mark on both the cup and paten is indistinct; it may possibly be an E.

This cup has a straight-sided bowl with a narrow raised band round the lip. The stem is a thick and plain round one, with a small moulding below the middle for a knob. The foot slopes down from the stem in a succession of small round mouldings. Round the bowl is; "*The gift of Bernard Whalley, the son of Bernard Whalley, to Norton church, 1728.*"

SILVER COVER PATEN with a foot. Weight 8.6 oz. Diam. $5\frac{1}{4}$ in. Diam. of foot $2\frac{1}{4}$ in. Height of foot $1\frac{1}{2}$ in. Date 1728. (PLATE 16.)

Hall marks as on the cup.

This paten has a flat edge, from whence the middle part is sunk flat. The foot is a disk, connected to the paten by a thick round stem.

SILVER DISH. Weight 11.1 oz. Diam. $8\frac{1}{2}$ in. Date 1729.

Hall marks. 1. Capital Roman O in a square pointed shield. 2 and 3. As on cup. 4. E. P., a lion rampant above within a shaped oblong: the mark of *Edward Pocock*.

This is a plain dish sunk in the middle, having a flat edge with a small moulding round it. Underneath is; "*The gift of Bernard, son of Bernard Whalley, of Norton.*"

The cup and paten, which were given to this church a year at least before the dish, are kept in a cylindrical case, covered with leather, made at the same time as the plate.

In the terrier of this parish for 1709, this plate is mentioned; "a silver cup, weight 6 oz., one pewter flagon, and two pewter plates." None of this was here in 1832.

The donor of this communion plate was the last representative of an ancient family, which sprung originally from Whalley, in Lancashire,* a younger branch settling subsequently at Bunny, in Nottinghamshire. From that branch sprung the **Whalleys**, of Norton, who took up their abode in this parish in the last half of the 16th century. Here they lived, owners of the manor of Norton, and other property, until the time of Mr. **Bernard Whalley**, the donor of the above-mentioned communion plate; who was born on 24th July, 1683, being the eldest son of **Bernard Whalley**, by **Lucy**, daughter of **John Baldwin**, of Geashill, Ireland: he was twice married, first on 20th July, 1712, to **Ann**, the daughter of **Charles Manning**, of Dartford, Kent, who died 28th June, 1734, aged 45: secondly to **Elizabeth Nicholas**, but died without issue, being buried in Norton churchyard, under the East end of the chancel. Over his grave is a slab of Swithland slate, with "*Ann Whalley*" at the top, below which are these words; "*Beneath this stone is likewise interred the body of Bernard Whalley, Esq^r. who died the 23rd of May, 1752, in the 69th year of his age, universally lamented.*"

Mr. **Bernard Whalley** dying childless, his property eventually passed into the hands of his first cousin, Mr. **William Fortrey**; who, when he rebuilt Norton church at great cost, did not pay much respect to the monuments of his ancestors, the **Whalleys**, who were buried inside the old church. Some of the slabs of blue marble over their graves were cut up to help to form the present diamond-shaped pavement within the sanctuary of the church; others

* For the pedigree of this family and other information, see *Nichols*, Vol. ii., p. 731.

were placed in their present position outside between the buttresses. **Bernard Whalley** being buried just outside the church, the slab to his memory is in its original position. The monument however which he had put up to his first wife, **Anne Manning**, against the East wall of the chancel, was taken down, the slab containing a long inscription to her memory being preserved, and placed on the ground by the side of her husband's monument mentioned above. The slab over the grave of his second wife, **Elizabeth**, was taken out of the floor of the church, and placed outside under the North side of the church. In addition to the Leicestershire property, Mr. **Whalley** inherited the manor of Billesley, co. Warwick, from his father: this estate he sold. (*Dugdale*, 1730, p. 718.) The arms of **Whalley** are; *Argent, three whales' heads erased, Sable*; Crest; *a whale's head erased, Sable*.

By his will, made 26th Jan., 1740, and proved at Leicester on 1st June, 1752, **Bernard Whalley** "of Norton Esq'" left to his wife **Elizabeth** all manors of Norton and Galby lately bought of Mrs. **Lætitia Street**; all land in Norton held by lease of the chaplain and poor of Wigston Hospital; all other freehold lands in England and all personalty, subject to the payment of his debts. She sole executrix. No one else mentioned.

STRETTON PARVA.

SILVER CUP. Weight 13.5 oz. Height 9 in. Diam. of bowl and of foot $4\frac{1}{4}$ in. Height of stem $4\frac{1}{2}$ in. Date 1782.

Hall marks. 1. Small Roman G in a square shield. 2. Leopard's head crowned in a rounded shield. 3. Lion passant in a plain oblong. 4. C. W. within a plain oblong. Probably mark of C. *Wright*.

This cup has a straight-sided bowl with a bell-shaped lip. In front is the sacred monogram within a circle of glory. The stem is a round thin one, with a small knob.

TWO PEWTER PLATES. Diam. of each $8\frac{1}{2}$ in.

Marks. 1. A rose of four petals crowned, with some illegible name above, repeated twice. 2. T. Letherbarrow. 3. In four small squares: (a) Lion passant. (b) Leopard's head. (c) A cock. (d) I. H.

The terrier of 1709 makes no mention of the church plate here. In 1832 the communion service consisted of a pewter cup and flagon and the above-mentioned pewter plates.

The silver cup was bought by subscription about sixteen years ago.

NOSELY.

In the chapel at Nosely, the seat of Sir **Arthur Hazlerigg**, Bart., is a **SILVER CUP.** Weight 10.7 oz. Height 8 in. Diam. of bowl $3\frac{1}{2}$ in.; of foot $3\frac{1}{4}$ in. Height of stem 4 in. Date 1835.

London hall marks.

This is a plain-shaped cup with a straight-sided bowl, and a baluster stem resting on a plain round foot. In front of the bowl is the sacred monogram, with a cross above, within a circle of glory.

SILVER PATEN with a foot. Weight 12.8 oz. Diam. $7\frac{1}{4}$ in. Diam. of foot $3\frac{1}{4}$ in. Height of foot $3\frac{1}{4}$ in. Date 1835.

London hall marks.

This paten is octagonal in shape, with the sacred monogram and a cross within a circle of glory in its centre. It has a plain round stem and foot.

SILVER DISH. Weight 13.8 oz. Diam. $9\frac{3}{8}$ in. Date 1835.

London hall marks.

This dish is octagonal like the paten, and has also the sacred monogram in its centre.

This communion service was given to Nosely chapel by Sir **Arthur Grey Hazlerigg**, the present baronet, and Lady **Hazlerigg**, his late wife. It has the additional interest of having been given for the celebration of the holy communion in the private chapel of Nosely in 1835, the year in which Sir **Arthur** and Lady **Hazlerigg** were married.

The communion plate in use at Nosely before this, was sold, it has been thought, several years ago.

SADDINGTON.

SILVER CUP. Weight 6.6 oz. Height $7\frac{1}{4}$ in. Diam. of bowl $3\frac{3}{8}$ in.; of foot $3\frac{1}{2}$ in. Height of stem $3\frac{1}{4}$ in. Date 1570. (PLATE 18.)

Hall marks. 1. Small black letter N in pointed shield, with small mark above. 2. Lion passant. 3. Leopard's head crowned, each of these two marks having an outside line following its outline. 4. An orb surmounted by a cross pommel.

The bowl of this cup is straight-sided below, swelling out into a bell-shaped lip. Round its middle is a band of foliage, divided into four parts by hour-glass curves. The stem is evenly-balanced, divided in half by a plain round knob. Underneath the bowl and round the edge of the foot is the egg and tongue ornament,

SILVER PATEN. Weight 4.5 oz. Diam. $6\frac{1}{2}$ in. Date 1844.

London hall marks.

In the centre of this plain paten is the sacred monogram, and on the back: "*A tribute of gratitude to Almighty God on her recovery from sickness, from Ann Dowell, 1844.*"

PEWTER FLAGON. Height $11\frac{1}{2}$ in. Diam. of top $3\frac{3}{8}$ in.; of foot $5\frac{1}{4}$ in.

Marks. 1. X crowned. 2. Lion passant repeated three times. 3. H. J.

This flagon is straight-sided in shape, narrowing towards the top.

PEWTER DISH. Diam. 9 in.

Mark. "London."

PEWTER BASIN. Diam. $9\frac{5}{8}$ in. Height 4 in.

No marks.

Upon the side is: "*J. Cooper, Saddington, 1744, Churchwarden.*"

There was formerly here what Archdeacon **Bonney** describes as a

"broken silver paten." This was parted with when the present paten was given.

The donor of this piece was **Ann**, the daughter of **Thomas Walker**, of Shearsby, by **Mary**, his wife, and was baptized at Shearsby on 8th June, 1783.* She was married at Shearsby to Mr. **William Dowell**, widower, of Saddington, on 29th Feb., 1816.* Mrs. **Dowell** was buried in the churchyard of this parish on 25th April, 1850.† No monument was erected to her memory.

It is interesting to notice that representatives of the two families of **Walker** and **Dowell** have been for many years Leicestershire yeomen. The former name has been long connected with Shearsby, and the latter with this parish and Bitteswell.

SCRAPTOFT.

(a)

SILVER CUP. Weight 10.5 oz. Height $8\frac{3}{8}$ in. Diam. of bowl 4 in.; of foot $3\frac{3}{8}$ in. Height of stem $4\frac{1}{8}$ in. Date 1740.

Hall marks. 1. Small Roman E in a shaped shield. 2. Leopard's head crowned in a shaped shield. 3. Lion passant in a shaped oblong. 4. F. S. with some object above, within a shaped shield; the mark of *Francis Spilsbury*.

This cup has a straight-sided bowl, swelling out towards the lip; a thick round stem, with a small moulding for a knob, and a small foot sloping down from the stem by a succession of small round mouldings.

(b)

SILVER PATEN with a foot. Weight 9.9 oz. Diam. $7\frac{7}{8}$ in. Diam. of foot $3\frac{1}{4}$ in. Height of foot $2\frac{1}{4}$ in. Date 1712.

Hall marks. 1. Court hand R in a pointed shield. 2. Lion's head erased. 3. Britannia. 4. L. O. in monogram, within an oval; the mark of *Matthew E. Lofthouse*.

This paten is quite plain in shape, with a plain round foot having a few mouldings running round its edge. In the centre within a lozenge are these arms: a stag's head caboshed between two flaunches, a crescent charged with a mullet for a difference, **Parker**. (FIG. 23.) Underneath the paten is "The gift of Mrs. Lucy Bradgate wido of the Rev^d Mr. Rich^d Bradgate, late Vicar of this parish, daughter of Mr. Parker, late citizen of London 1740."



Fig. 23.

(c)

SILVER DISH with a foot. Weight 9.9 oz. Diam. 9 in. Diam. of foot $3\frac{3}{8}$ in. Height of foot $2\frac{1}{4}$ in. Date 1705.

* Parish Register.

† Parish Register

Hall marks. 1. Court hand K in a pointed shield. 2. Lion's head erased. 3. Britannia. 4. Capital old English L and small o, a mullet below, within a plain shield. The mark of *Seth Lofthouse*.

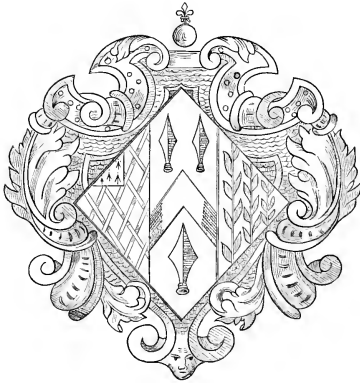

Fig. 24.

This dish is quite plain in character, being of the same shape as the paten. In the centre are the arms of the donor impaling, on the dexter and sinister sides the arms of her second and first husbands; these being, *Sable, a chevron between three spear heads Argent; Armston; impaling, on the dexter side; Or, fretty Gules, a canton Ermine; Noel. On the sinister side; paly of six* embattled Argent and Gules; Wigley.* (FIG. 24.) Round the coat of arms is "*Ex dono dominae Noel Andræ Noel militis relicta Scriptoft.*"

(a)

SILVER FLAGON. Weight 52.7 oz.

Height $12\frac{1}{2}$ in. Diam. at top $4\frac{1}{2}$ in.; at foot $7\frac{5}{8}$ in. Date 1745.

Hall marks. 1. Small Roman K in a shaped shield. 2. Leopard's head crowned in a shaped shield. 3. Lion passant in a shaped oblong. 4. W. W., with a pellet between, an annulet below and a cinquefoil above, within an oval; mark of *William Williams*.

This is a straight-sided flagon narrowing towards the top, having a large foot, a plain round handle and a lid with a round top. In front is: "*The gift of Letitia, Lady Wigley, relict of Sr Edward Wigley, Kt. 1746.*"

In the terrier for 1712 for this parish we are told that the "communion plate is one cup with a cover and one salver about five pounds value given by the Lady Noel." We may conclude that the cup and cover were Elizabethan, and were parted with when the present cup was bought; they at any rate did not exist when Archdeacon **Bickham's** inventory of the church plate of this parish was made in 1780.

(b)

The silver paten, originally a secular piece of plate, was bequeathed by Mrs. **Bradgate** in a codicil to her will dated 21st July, 1740, and proved in Leicester the same year, with these words; "*My largest silver salver shall be given for the use of the communion at the church of Scriptoft. and to have my name engraved upon it.*" Of the parentage of this lady I know no more than what is recorded in the inscription on her gift. She seems to have been connected before her marriage in some way with the borough of Leicester, for she is described in her marriage bond as of St. Martin's.† **Lucy Parker** married

* Paly of eight is the right bearing.

† *Transac. of Leic. Archæo. Soc.*, Vol. vii.

the Rev. **Richard Bradgate**, as his second wife, at St. Margaret's, Leicester, on 30th Sep., 1718.* His first wife had been **Ann**, eldest daughter of **George Purefoy**, of Woolvershill, Warwick, whom he married at Scraftoft, on 12th August, 1701,† and who died on 4th May, 1710, aged 46, leaving one child **Edward**, afterwards rector of Bruntingthorpe. **Richard Bradgate**, who sprang from the Peatling Parva family, was vicar of this parish from 1694, and rector of Foston from 1704, till his death on 30th April, 1733, aged 77. His second wife, **Lucy**, died leaving no issue, and was buried here on 15th Aug., 1740.†

In her will **Lucy Parker** leaves a legacy to her "son-in-law," **Edward Bradgate**, clerke; and 30s. to the poor of Scraftoft. Seal: *stag's head caboshed between two flaunches, crescent for difference.*

(c)

The donor of the silver dish was **Ann**, the daughter of **James Armston**, Esq., of Burbage, by **Anne** the daughter and co-heir of **George Wale**, of Walcote, and was baptized at Burbage on 19th Dec., 1637.‡ She married first at Burbage, on 5th Feb., 1656,‡ **Edward Wigley**, Esq., the representative of a family resident in Scraftoft since the time of **Henry VIII.**, who died on 22nd Feb., 1660, and secondly in 1665, **Andrew Noel**, of Whitwell, co. Rutland, the son of **Alexander Noel**, by **Mary**, sister to Sir **Geoffrey Palmer**, 1st Bart., to whom are slabs in Whitwell church. Sir **Andrew Noel**, who was knighted on 6th Aug., 1681, was buried at Exton on 27th Sep., 1689. Lady **Noel** survived her second husband and died upon 24th Dec., 1706. She was buried in the chancel of Scraftoft church, a flat stone being placed over her grave, the inscription on which tells that by her first husband "she had three sons, two dead, and Sir **Edward Wigley**, knight, now living; by her last husband she had likewise three sons, two dead, and **Andrew Noel**, Esq., now living." Lady **Noel** became heir to her brother, **James Armston**, at his death on 27th Sep., 1704.

This gift must have been made by **Ann**, Lady **Noel**, either just before her death or else by her executors in accordance with her verbal instructions. In her will made 7th Dec., 1706, and proved on 25th Jan., 1706, O.S. in Leicester, this lady left 5 guineas to Mr. **R. Bradgate**, rector, and £2 to each of these parishes for their poor, Scraftoft, Walcote and Burbage; to her granddaughter **Catherine Wigley**, £50 at age of 16; residuary legatees and executors, her sons Sir **Edward Wigley**, and **Andrew Noel**, Esq. Seal: arms of **Noel**.

(a)

The silver cup and flagon were bought for this church in accordance with the following clause in **Lætitia Lady Wigley's** will, dated 20th June, 1740, and proved in Leicester in 1746. "Unto the parish church of Scraftoft a silver flagon, silver cup and a silver plate, which I wish and desire my executor may

* Parish Register.

† Parish Register.

‡ Parish Register.

buy and purchase within six calendar months next after my decease as large and neat as to him shall seem most meet and convenient to be used at the celebration of the most holy sacrament there for ever." Lady **Wigley's** executors probably thought it unnecessary to buy a silver plate since the church had meanwhile inherited Mrs. **Bradgate's** gift.

This lady was the daughter and heir of **Arthur Cressy**, Esq., of Brigsley, Lincolnshire, and married in 1694 Sir **Edward Wigley**, knighted at Windsor 14th Aug., 1683, thus becoming the daughter-in-law of **Ann**, Lady **Noel**. Sir **Edward Wigley** died on 8th March, 1711, aged 52; his widow, **Lætitia**, on 23rd April, 1746, in the 76th year of her age. They were buried within the sanctuary of Scraptoft church, blue slate slabs being placed over their graves.

There is also upon the North wall of the chancel a marble monument to their memory containing their busts, and in the upper part the arms of **Wigley**, and, on an escutcheon of pretence, *Argent, a lion rampant Sable, on the dexter canton a cinquefoil Gules*; **Cressy**; this monument was erected by **Lætitia Lady Wigley**, in her life-time.

Lætitia Lady Wigley, left £60 to the poor of Scraptoft, Keyham, Humberstone, Thurnby, Bushby, Burbage, and Walcote in this county, and Brigsley, Grainthorpe, Skidbrooke, Somercotes, and Kirmington in the county of Lincoln; also £400 towards augmenting, with the help of Queen **Anne's** Bounty, the livings of Great Randle* and Kirmington; and £200 to repair and alter the church in the former parish. Legacy to godson **Richard**, son of her cousin **Richard Cressy**, clerk, of Great Randle.

Sir **Edward** and Lady **Wigley**, had an eldest son **James Wigley**, M.P., who died s.p. in 1765, and a daughter **Lætitia**, married to **Samuel Hartopp**, of Little Dalby, whose grandson **Edward Hartopp**, eventually inherited the **Wigley** estates in this parish, now owned by his descendant Miss **Hartopp**, of Little Dalby.†

SHANGTON.

SILVER CUP WITH COVER PATEN. Weight of cup 10.9 oz. Height 6½ in. Diam. of bowl and of foot 4¼ in. Height of stem 2¾ in. Date 1669.

Hall marks. 1. Capital old English M in plain pointed shield. 2. Lion passant. 3. Leopard's head crowned, each of these two marks having an outside line following their outline. 4. R. S., a mullet above and below, in a shaped shield.

The bowl of this cup is straight-sided, very slightly bell-shaped. It has a plain round stem without a knob, and a flat foot.

SILVER COVER PATEN with foot. Weight 5.7 oz. Diam. 5¾ in. Diam. of foot 2¾ in. Height of foot ⅞ in. Date 1669.

Hall marks as on the cup.

The edge of this plain paten, to the width of ¼ in., is raised above the middle part, thus allowing the cover to fit on to the cup. On the foot is engraved a radiated star. The lion passant is repeated underneath the feet of both cup and cover.

* Ravendale.

† For pedigree of **Wigley**, vide *Nichols*, Vol. ii., p. 788.

At the time this cup and cover paten were purchased the lord of the manor and principal landowner in Shangton was Sir **Justinian Isham**, 2nd Bart., of Lamport, Northants, the ancestor of the present baronet, Sir **Charles Edmund Isham**.

SMEETON WESTERBY.

SILVER GILT CUP. Weight 10.5 oz. Height $7\frac{1}{8}$ in. Diam. of bowl 4 in.; of foot 5 in. Height of stem $4\frac{7}{8}$ in. Date **1847**.

London hall marks.

The bowl of this cup is hemispherical in shape, the stem, knob and foot being hexagonal. The sacred monogram is engraved upon one side of the foot.

SILVER GILT PATEN. Weight 4.3 oz. Diam. $6\frac{5}{8}$ in. Date **1849**.

London hall marks.

This paten has a wide flat edge, within which is sunk a six-lobed depression, with the Vernicle in the centre.

SILVER GILT FLAGON. Weight 12.6 oz. Height $10\frac{3}{8}$ in. Date **1848**.

London hall marks.

This is a small and narrow "round-bellied" flagon, with a tall and narrow pipe for a spout, rising up from the middle. Round the middle is "*Te laudamus tibi benedicimus.*"

This service of communion plate was bought for Smeeton church at the time when it was built, in 1849, under the auspices of the then rector of Kibworth, the Rev. **H. A. Bathurst**.

THURNBY.

SILVER CUP. Weight 6.5 oz. Height $5\frac{3}{4}$ in. Diam. of bowl $3\frac{3}{4}$ in.; of foot $3\frac{1}{4}$ in. Height of stem $2\frac{5}{8}$ in. Date *circa* **1575**. (PLATE 14.)

Mark. A rose, very indistinct.

This cup has a bowl, an inverted truncated cone in shape with a flat base, round which is a band of stroke ornament divided into six parts by hour-glass curves. The stem, which is evenly-balanced, is divided in half by a low knob, from whence it swells out a little towards its upper and lower ends, round each of which is the vertical reed ornament. The foot is a wide one, the vertical reed ornament running round its edge.

SILVER PLATED CUP. Height $7\frac{3}{4}$ in. Diam. of bowl $3\frac{5}{8}$ in.; of foot 4 in. Height of stem 4 in.

Marks. 1. An orb with a cross on it. 2. W. F.

This cup has a straight-sided bowl and a baluster stem.

SILVER PLATED PATEN. Diam. $5\frac{5}{8}$ in.

SILVER PLATED DISH with a foot. Diam. 9 in. Diam. of the foot $4\frac{3}{8}$ in. Height of the foot $3\frac{1}{2}$ in.

Mark. Cross keys.

SILVER PLATED FLAGON. Height $11\frac{3}{4}$ in. Diam. at top $3\frac{3}{4}$ in. Diam. of foot 6 in.

Same marks as on cup.

In shape straight-sided, with a spout at the top.

In an undated terrier, probably of 1709, for Thurnby and Stoughton, the church plate is recorded to be in this parish, "one old silver cup about half a pound in weight, no inscription; a pewter flagon and a pewter plate. Same at Stoughton."

The silver plated pieces were the gift of Mrs. Jackson, of Thurnby Court.

STOUGHTON.

SILVER CUP. WEIGHT 10.4 oz. Height $6\frac{5}{8}$ in. Diam. of bowl $3\frac{7}{8}$ in.; of foot $3\frac{3}{8}$ in. Height of stem $3\frac{1}{2}$ in. Date 1640. (PLATE 14.)

Hall marks. 1. Court hand C in a plain pointed shield. 2. Lion passant. 3. Leopard's head crowned; each of the two latter having an outside line following its outline. 4. R. G. with three pellets below, within a shaped shield.

The bowl of this cup is in shape an inverted truncated cone having a flat base. A baluster stem, with flat foot, completes its description. The edge of the foot is turned round underneath. This cup, like most of this shape, is strongly made of thick metal.

SILVER PATEN with a foot. Weight 8.2 oz. Diam. $6\frac{1}{2}$ in. Diam. of foot $3\frac{1}{2}$ in. Height of foot 2 in. Date 1866.

London hall marks.

Round the edge of this paten, which is quite plain in shape, is "*That they all may be one as Thou Father art in Me and I in Thee, that they also may be one in Us.*" Underneath is, "*Offered to Stoughton church by Maria, widow of Major the Honble Henry Littleton Powys Keck, of Stoughton Grange, 1866.*"

SILVER FLAGON. Weight 17.1 oz. Height $10\frac{3}{4}$ in. Diam. at the top $2\frac{7}{8}$ in.; at the foot $3\frac{3}{8}$ in. Date 1865.

London hall marks.

This is a jug-shaped flagon with a flat lid rounded off at the edge, and a purchase in the shape of a cross. Round its middle is, "*If we walk in the light as He is in the light we have fellowship one with another, and the blood of Jesus Christ His son cleanseth us from all sin.*" Underneath the foot is the same inscription as that under the paten.

SILVER DISH. Weight 13.4 oz. Diam. $9\frac{1}{4}$ in. Date 1732.

Hall marks. 1. Capital Roman R in a plain pointed shield. 2. Leopard's head crowned in a pointed shield. 3. Lion passant in a plain oblong. 4. I. S. in monogram, in script letters, within a square; mark of *Joseph Sanders*.

This dish, which is quite plain in shape, has round its edge this text, "*That in the dispensation of the fulness of times He might gather together in one all things in Christ, both which are in Heaven, and which are on earth.*" Underneath this dish in the middle is "*E D., H C., 1732.*" And on the edge there is the same inscription as that under the paten. Perhaps this dish formerly belonged to some other church: if so, the letters and date underneath may have been the initials of the churchwardens of that church, and the date at which they bought the dish.

PEWTER PLATE. Diam. $9\frac{3}{4}$ in.

Marks. 1. In three small shaped squares on the edge. (a) Lion passant. (b) Leopard's head crowned. (c) A lily. 2. On back, "London." 3. On a shield, three anchors; some illegible name above. 4. A rose, very indistinct. On the edge of this plain plate is "*Stouton W.F.*"

PEWTER PLATE. Diam. $9\frac{1}{4}$ in.

Marks underneath. 1. X crowned. 2. Rising out of a crown, a dexter arm embowed, vambraced, the hand holding a spear. 3. "London." 4. In four small shaped shields; (a) Per chevron engrailed, three leopards' faces. (b) A dexter arm embowed, vambraced, the hand holding a spear. (c) A fleur-de-lis. (d) S.I. On the edge is "*Stoughton 1780. Neal Cobby, churchwarden.*"

PEWTER BASIN. Diam. 8in. Height $2\frac{1}{8}$ in.

Marks. 1. A rose crowned. 2. "London."

Sir **Henry Beaumont**, Knt., of **Stoughton Grange**, was lord of the manor and sole landowner of **Stoughton** in 1640.

The Hon. Mrs. **Powys Keck**, the donor of the silver paten, flagon, and dish, is the youngest surviving daughter of the late Admiral Sir **John Gore**, G.C.B., G.C.H. She married on 16th July, 1862, as his second wife, Major the Hon. **Henry Littleton Powys Keck**, of **Stoughton Grange**, fifth son of the 2nd Lord **Lilford**, who died on 10th July, 1863.

WISTOW.

SILVER GILT CUP. Weight 10.8 oz. Height $7\frac{7}{8}$ in. Diam. of bowl, of foot, and Height of stem $3\frac{1}{2}$ in. Date 1777.

Hall marks. 1. Small Roman B in a square shield. 2. Leopard's head crowned in an oval shield. 3. Lion passant in a plain oblong. 4. Capital Roman S and indistinct letter in oblong.

This is a strongly made cup, with a straight-sided bowl, baluster stem, and plain round foot. Upon the bowl is the sacred monogram with a cross above and three nails below, within a circle of glory.

SILVER GILT PATEN with a foot. Weight 4.5 oz. Diam. $4\frac{1}{4}$ in. Diam. of foot $1\frac{3}{8}$ in. Height of foot 1 in. Date 1777.

Hall marks as on the cup.

This paten is quite plain in shape, with the sacred monogram in its centre.

SILVER GILT DISH. Weight 12.3 oz. Diam. $8\frac{1}{2}$ in. Date 1777.

Hall marks as on the cup.

This is a perfectly plain dish with the sacred monogram, cross, and nails, within a circle of glory in the centre.

It is not very likely that any one else except either Sir **Charles Halford**, 7th Bart., or his lady presented this service of communion plate to **Wistow church**. Sir **Charles** was the fourth son of **Thomas Halford**, Esq., by

Elizabeth, daughter of **Thomas Palmer**, Esq., of Leicester, and was born on 15th April, 1732. Since his brothers had all died leaving no issue, he succeeded at the death of his uncle Sir **William Halford**, 6th Bart., on 3rd Feb. 1768, both to the baronetcy and also to the estate at Wistow, which had been owned by this family since 1603. **Sir Charles**, who filled the office of high sheriff of the county in 1769, married on 3rd May in the same year, **Sarah**, youngest daughter of **Edward Farnham**, Esq., of Quorndon, by **Easter Lake**, of Canterbury. He died without issue on 21st July, 1780. He was the last known heir male of the Wistow branch of this ancient family. The parent stock, the **Halfords** of Welham, who had been settled in that parish from the time of Queen **Elizabeth**, had disappeared early in the eighteenth century; and another branch of the same family, the **Halfords** of Edith Weston, co. Rutland, had also ceased to be represented in the male line, at the death of **Richard Halford**, Esq., in 1742.* **Sir Charles Halford's** widow, who had a life interest in the Wistow estates, married secondly, on 21st July, 1783, **Basil**, 6th Earl of **Denbigh**; upon her death on 2nd Oct., 1814, this property in accordance with her first husband's will, passed to Sir **Henry Vaughan**, Bart., whose maternal grandmother was **Elizabeth Halford**, aunt to Sir **Charles Halford**, and wife of Alderman **John Smalley**, of Leicester.† **Sir Charles Halford**, Bart., was buried in the transept of Wistow church, upon the West side of which is a marble monument to his memory with these arms in the upper part; *Argent a greyhound passant Sable; on a chief Azure three fleur-de-lis Or; Halford; impaling: Quarterly, Or and Azure; in the two first quarters two crescents counterchanged; Farnham.*‡

NEWTON HARCOURT.

SILVER CUP. Weight 4.9 oz., including a little lead in the foot. Height 4 $\frac{3}{8}$ in.; Diam. of bowl 3 in., of foot 2 $\frac{3}{8}$ in. Height of stem 1 $\frac{3}{8}$ in. Date 1568.

Hall marks. 1. Small black letter **L** in pointed shield. 2. Lion passant in a plain oblong. 3. Leopard's head crowned with an outside line following its outline. 4. R. D. in monogram within a plain pointed shield.

This little cup has a bowl shaped like an inverted truncated cone, its sides being slightly concave, and base flat; there are traces of the inside of the bowl having been gilt. Round the outside, close to the lip, runs a band of Elizabethan foliage $\frac{1}{2}$ an inch wide, a similar narrower band running round the lower part of the bowl; each is divided into four parts by hour-glass curves. The stem has every appearance of having been formerly cut in half

* This branch of the Halford family is now represented in the female line by George Vere Lucas Braithwaite, Esq., of Edith Weston Hall. † See Kilby, p. 214. ‡ For inscription, see *History of Market Harborough*, by Rev. J. H. Hill, F.S.A., p. 320.

through the middle of the knob, the upper half being left forming the stem as it now is; below this half knob is the original lower edge of the stem, round which as well as round the upper edge runs a very small lozenge ornament. The foot, which is of the usual shape, has round its edge the egg and tongue ornament.

SILVER PATEN with a foot. Weight 1.6 oz. Diam. $3\frac{3}{4}$ in. Diam of foot 1 in. Height of foot $\frac{5}{8}$ of an inch. Date 1568.

Hall marks as on the cup, with the exception of the maker's mark being a fleur-de-lis in a plain pointed shield.

This cannot be called a cover paten since it does not fit on to the cup as such; there are no signs of any rim ever having been round its inside; it fits however on to the cup with the foot downwards. It has a flat edge $\frac{1}{4}$ an inch wide, the middle part within being sunk in a hollow. Round the top of the paten is a band $\frac{3}{8}$ of an inch wide formed by two straps enclosing three rows of little horizontal strokes, the straps being connected together in four places by a couple of short straps placed diagonally across the band. The foot is a plain button attached to the paten by a straight round stem.

PEWTER PLATE. Diam. $8\frac{7}{8}$ in.

No marks.

This is a plain flat plate with a vertical edge $\frac{3}{4}$ of an inch high.



“‘What are ye?’ said the good man.

“‘Sir,’ said Sir Hoes, ‘I am a knight that fain would be counselled in the quest of the Sangreal; for he shall have much earthly worship that may bring it to an end.’

“‘Certes,’ said the good man, ‘that is sooth, for he shall be the best knight of the world, and the fairest of all the fellowship.’”

GARTREE THIRD DEANERY.

ALEXTON.
BILLESDON.
GOADBY.
ROLLESTON.
BLASTON ST. GILES.
BRINGHURST.

GREAT EASTON.
HALLATON.
BLASTON ST. MICHAEL.
HORNINGHOLD.
LODDINGTON.
MEDBOURNE.

NEVILL HOLT.
SKEFFINGTON.
STOCKERSTON.
TUGBY.
EAST NORTON.



ALEXTON.

SILVER CUP. Weight 6.5 oz. Height $6\frac{3}{8}$ in. Diam. of bowl $3\frac{3}{8}$ in.; of foot $2\frac{1}{2}$ in. Height of stem $2\frac{3}{8}$ in. Date *circa* 1570. (PLATE 18.)

One mark only, the leopard's head crowned, with an outside line following the outline of the mark.

This cup is very similar to the one at Stonesby,* made by the same maker; its bowl is an inverted truncated cone, with a bell-shaped lip, the lower part being nearly straight-sided. Its short stem has no knob. Round the edge of the foot is the egg and tongue ornament.

SILVER PATEN. Weight 10.4 oz. Diam. $8\frac{1}{2}$ in. Date *circa* 1652.

Hall marks. 1. An angular circle with three vertical lines rising out of the top, within a plain pointed shield: perhaps court-hand O, mis-struck. 2. Leopard's head crowned. 3. Lion passant; each of the two latter having an outside line following its outline. 4. R.E., with a mullet below, in a heart-shaped shield.

This paten is flat in shape, the middle part, to the extent of 5 inches in width, being slightly sunk; leaving a wide flat edge.

SILVER PLATED ALMS BASIN. Diam. 10 in.

In the centre there is the sacred monogram.

SILVER PLATED FLAGON. Height $10\frac{1}{4}$ in.

This flagon is jug-shaped, and was with the basin, bought a few years ago.

PEWTER FLAGON. Height $9\frac{3}{4}$ in. Diam. of top $3\frac{1}{4}$ in.; of foot 4 in.

Marks. 1. X crowned. 2. Four small marks, (a) An ornamental R. (b) I. (c) Lion passant between four pellets. (d) A flower between two leaves.

This flagon is straight-sided in shape, narrowing a little towards the top. It has an R shaped handle and a lid rising up in mouldings with a tall knob at the top.

PEWTER DISH. Diam. $9\frac{1}{4}$ in.

Mark. X crowned; and one or two illegible marks.

The following is a copy of a memorandum made in the parish register relating to the silver paten;

* Plate 10.

"Memorandum that **Richard Verney**, Esquire, did freely give at his coming to live at the hall in this parishe a silver plate for carriage of the consecrated bread in the time of the administration of the Lord's supper. Anno Domini 1652. **Mountjoy Cradock**, Rector."

The donor was the second son of **Sir Greville Verney**, Knt., of Compton Verney, Warwickshire, by **Catherine**, daughter of **Sir Robert Southwell**, Knt., of Woodrising, Norfolk, and was born at Kingston, Warwickshire, on 28th Jan., 1621. From the above entry in the register we learn that it was in 1652, or shortly before, that Mr. **Richard Verney** bought the entire lordship of Alexton from **Mountjoy Blount**, Earl of Newport. He was high sheriff of Rutland in 1682, and of Warwickshire in the year following; in which year he moved from Alexton to Compton Mundac, upon succeeding to the old family property there, owing to the death of **William Verney**, the only son of his eldest brother **Sir Greville**. In 1685, Mr. **R. Verney** was returned to parliament for Warwickshire, and knighted by King **James II.**, on 1st April; his eldest son **John** being elected member of the same parliament for Leicestershire. **Sir Richard** was again returned for Warwickshire in 1688; soon after which date he began to prefer his title to the barony of **Willoughby de Broke**, which he claimed owing to his descent from **Robert, Lord Willoughby de Broke**, through his grandmother **Margaret**, sister and heir of **Fulk Greville, Lord Broke**; this title was allowed him on 13th Feb., 1695. **Lord Willoughby de Broke** was evidently in his day a leading man in the three counties of Rutland, Leicester, and Warwick: **Dugdale** speaks of him as a man who was "highly honoured and beloved by all that knew him;"* and praises his antiquarian knowledge, which praise we find echoed in **Wright's** antiquities of Rutland. The donor of this patent died upon 28th July, 1711, and was buried in Compton Mundac church. He was twice married; first to **Mary**, the eldest daughter of **Sir John Pretzman**, Knt., of Loddington, who died on 17th August, 1663, aged 30, and was buried on the North side of the chancel of Alexton church; by her he had six children, of whom the second son, **George**, succeeded his father, and is the ancestor of the present **Lord Willoughby de Broke**. **Richard, Lord Willoughby de Broke**, married secondly **Frances**, the daughter of **Thomas Dove**, of Upton, Northants, by his first wife **Frances**, daughter of **William Becke**, of Castleacre, Norfolk; by her he had a son who died young, and a daughter, **Diana**, married to **Sir C. Shuckburgh, Bart.**

There was formerly over the grave of **Lord Willoughby de Broke's** first wife a black marble slab bearing an inscription, and these arms at the top; *Gules three crosses recercellé Or; a chief vairé ermine and erminois; Verney; with a crescent for a difference; impaling Gules, a lion passant guardant in fesse between three mullets Or; Pretzman. Crest: An antelope sejant Argent*

* *History of Warwickshire*, Vol. i., p. 565, Ed. 1730.

guttée de sang, armed Or. On the opposite side of the chancel a brick vault was prepared by Lord Willoughby for himself, over which he placed a slab bearing the same arms but no inscription. These slabs are in their original condition but not position; they were both placed in the North aisle when this church was restored in 1862.

There is no monument in Compton Mundac church either to Lord Willoughby de Broke or to his second wife.

BILLESDON.

SILVER CUP. Weight 6.7 oz. Height $6\frac{1}{8}$ in. Diam. of bowl $3\frac{7}{8}$ in.; of foot $3\frac{1}{2}$ in. Height of stem $2\frac{5}{8}$ in. Date *circa* 1575. (PLATE 15.)

There is only one mark on this cup—a rose.

This cup is of the same shape as others of this series, having a bowl shaped into an inverted truncated cone, with a flat base. Round the bowl is a band of stroke ornament, divided into six parts by hour-glass curves. The stem is evenly-balanced, swelling out at both ends, having in its middle a small round moulding for a knob. Round both ends of the stem and round the edge of the foot is a vertical reed ornament.

SILVER CUP, parcel gilt. Weight 12.1 oz. Height $6\frac{1}{2}$ in. Diam. of bowl 4 in.; of foot 5 in. Height of stem $4\frac{1}{4}$ in. Date 1874.

London hall marks.

This cup has a globular-shaped bowl with an hexagonal stem and foot. In the middle of the stem is a large hexagonal knob, on the edge of which are six diamond-shaped bosses with lions' faces upon them. The edge of the foot is shaped into six cusps, over one of which is the sacred monogram.

SILVER PATEN, parcel gilt. Weight 4.6 oz. Diam. $5\frac{1}{2}$ in. Date 1874.

This paten fits on to the cup. It is sunk in the middle in a six-lobed depression, the sacred monogram being in the centre within a hexagonal design.

SILVER DISH with foot, parcel gilt. Weight 9.5 oz. Diam. 7 in. Diam. of foot $4\frac{1}{2}$ in. Height of foot $1\frac{1}{2}$ in. Date 1874.

This dish is just the same in shape as the paten, its foot being of much the same shape as the foot of the cup.

SILVER FLAGON, parcel gilt. Weight 24.5 oz. Height 12 in. Diam. at the top $1\frac{3}{4}$ in.; at the foot $4\frac{7}{8}$ in. Date 1874.

This is a jug-shaped flagon, with a cross on its lid and a cross for a purchase. It has an R-shaped handle; its foot is the same in shape as the foot of the cup. Round its neck is an ornamental band, and in front, in the middle, the sacred monogram within a hexagonal shape.

SILVER ALMS DISH, parcel gilt. Weight 22.3 oz. Diam. $12\frac{1}{2}$ in. Date 1874.

This alms dish is the same in shape as the paten, being sunk in the middle in a six-lobed depression, having the sacred monogram in its centre.

PEWTER FLAGON. Height 12 $\frac{1}{4}$ in. Diam. at the top, 4 $\frac{1}{2}$ in.; at the foot 6 $\frac{3}{8}$ in.

Mark on the back of the handle. I. N., a pellet being above each letter, one fleur-de-lis below, within a shaped shield. This is a wide, straight-sided flagon, narrowing towards the top. Its lid rises up to a round knob on its top. The foot projects only a little. In front of the flagon is: "1713 B. W. C. I. N." B. being for Billesdon, the other initials for the two churchwardens.

TWO PEWTER PLATES. Diam. of each 9 in.

Marks. 1. A rose crowned, with "Tho." above, and an illegible name below, beginning with L. On one side of the rose is I., possibly N. is on the other side. 2. "London."

This plate has a flat edge 1 $\frac{1}{4}$ in. wide, the middle being sunk to the depth of $\frac{3}{8}$ in. On the edge is: "C. W. I. N."

The five silver pieces, parcel gilt, form a good modern communion service. Each piece is of frosted silver, and of thicker metal than usual. It was bought for this church in the year 1874, costing £60 7s. 6d., that sum of money being the amount of the offerings made by the communicants of the church for this purpose during the year preceding.

GOADBY.

SILVER CUP WITH COVER PATEN. Weight of cup 6 oz. Height 5 $\frac{1}{8}$ in. Diam. of bowl 3 $\frac{3}{8}$ in.; of foot 2 $\frac{3}{8}$ in. Height of stem 2 $\frac{1}{8}$ in. Date *circa* 1570. (PLATE 15.)

Mark. Capital Roman G N, between the letters a female head within a shaped shield; both the letters are stamped backwards; the G is on the right and the N on the left of the shield containing the head.*

This cup has a deep and nearly straight-sided bowl with a flat projecting base. The stem is a plain round short one without a knob. The foot is of the usual shape with the egg and tongue ornament round its edge.

SILVER COVER PATEN. Weight 1.4 oz. Diam. 3 $\frac{1}{8}$ in. Date *circa* 1570. (PLATE 15.)

No marks.

This paten is somewhat dome-shaped. Its foot and also the rim inside have been broken off, apparently several years ago: the former was a small button attached to the paten by a short stem $\frac{1}{4}$ of an inch thick.

SILVER PATEN. Weight 3.9 oz. Diam. 6 in. Date 1864.

London hall marks.

This is a flat paten with a raised moulded edge. In the centre within a hexagon is the sacred monogram.

PEWTER FLAGON. Height 10 $\frac{1}{2}$ in. Diam. at the top 3 $\frac{1}{2}$ in.; at the foot 4 $\frac{1}{2}$ in.

No marks.

This is a small straight-sided flagon narrowing a little to the top. Which has a round top with a knob on the top.

* *Vide* Wyfordby, p. 147., Plate 10.

PEWTER PLATE. Diam. $9\frac{5}{8}$ in.

Marks; on the edge. 1. A large crown surrounded with conventional foliage. 2. In three small squares, (a) leopard's head crowned; (b) a bird; (c) a buckle. 3. On the back, a rose crowned. The crown was probably the mark of some former owner.

In an undated terrier for this parish at Lincoln, signed **T. Smith**, Vicar, **Tho. Woodcock**, Churchwarden, there is said to be "in the chappel a silver cup with a cover, the flagon pewter." This terrier was probably made in 1709.

The modern silver paten was purchased with money from the offertory fund in 1885.

ROLLESTON.

SILVER CUP. Weight 7.8 oz. Height $8\frac{3}{8}$ in. Diam. of bowl 4 in.; of foot $3\frac{5}{8}$ in. Height of stem $3\frac{5}{8}$ in. Date 1737.

Hall marks. 1. Small Roman B in a plain pointed shield. 2. Leopard's head crowned in a plain pointed shield. 3. Lion passant in a plain oblong. 4. F. S., a pellet between the letters and a fish below, within a heart-shaped shield. The mark of *Frances Spilsbury*.

The bowl of this cup is in shape an inverted truncated cone, having a bell-shaped lip. The stem is a plain, thick, round one, swelling out to the bottom of the bowl and to the foot; it has below its middle a plain round moulding for a knob. The foot is of the ordinary kind, with some mouldings running round it.

SILVER PLATE. Weight 9.8 oz. Diam. $9\frac{1}{4}$ in. Date 1737.

Hall marks as on the cup.

This is a perfectly plain plate, with a flat edge, the middle part being sunk.

SILVER PLATE. Weight 9.5 oz.

Just like the last.

SILVER FLAGON. Weight 23.1 oz. Height $10\frac{1}{4}$ in. Diam. at the top $2\frac{7}{8}$ in.; at the foot $3\frac{7}{8}$ in. Date 1737.

Hall marks as on the cup.

This is a jug-shaped flagon with a short thick neck, having a spout at the top covered in half-way. It has a thick round handle and a plain round foot. Its lid has a flat top surmounted with a knob.

In all probability this parish owes its service of communion plate to the generosity of **Richard Greene**, Esq., who, according to *Nichols*, completely repaired Rolleston church both inside and out, in about the year 1740. This gentleman was born on 5th July, 1704, being the only son of **Henry Greene**, of Rolleston, by his wife and cousin **Elizabeth**, one of the daughters and co-heirs of **Richard Greene**, of Wykin. The donor of this service married at Blaston St. Giles, on 20th Nov., 1726, **Catherine**, the daughter of **William Fortrey**, Esq., of King's Norton, by whom he had a son **Henry**, in holy orders, who succeeded to the **Fortrey**, and formerly **Whalley**, estates in Norton and Gaulby. Mr. **Richard Greene**, who was high sheriff for the

county in 1731, died in January, 1781; his wife **Catherine**, who was born on 2nd July, 1702, died in May, 1778. Mr. **Greene** bore these arms: *Vert three bucks trippant Or within a bordure of the last.* Crest: *Out of park pales a stag's head proper, attired Or.**

BLASTON ST. GILES.

SILVER CUP, parcel gilt. Weight 6.8 oz. Height 5½ in. Diam. of bowl 3½ in.; of foot 4½ in. Height of stem 3½ in. Date *circa* 1500. (FIG. 25.)



Fig. 25, circa 1500, about full size. M.P. del.

* For pedigree see *Nichols*, Vol. ii., p. 446.

No hall marks.

This little pre-Reformation chalice is of great interest in spite of its having been much "restored." It closely resembles a communion cup at Hornby, Lancashire, described and figured by Mr. W. H. St. John Hope.* It has a hemispherical bowl, hexagonal stem, knob and foot. On the knob are six bosses bearing daisies in relief; in between the bosses is tracery on both sides of the knob, much worn. On one division of the foot is engraved a figure of the Saviour on the cross, in the midst of ivy-leaved foliage, "I.N. R.I." above. The edge of the foot is reeded, and at each of the six angles is a fleur-de-lis-shaped knob, bearing a daisy similar to those on the bosses of the stem. Beneath the foot, in the middle, is a plate thus inscribed: "*St. Giles' Chapel, Blaston, Leicestershire.*" In 1842 this chalice was sent to Messrs. Hardman, who repaired it at a cost of £14 14s.† I take the bowl to date only from that time; it has every appearance of being completely modern, and is probably shallower than the original one. The engraving of the crucifix and foliage on the foot is so clear and sharp that there must have been a good deal of "touching up" done here, if the whole device has not been renewed. The inscribed plate under the foot was inserted at that time.

It may be that this chalice survived the exchange of communion plate in the reign of Elizabeth, through the chapel of St. Giles being a donative, exempt from the jurisdiction of the Bishop.

SILVER PLATED PATEN. Diam. $6\frac{3}{4}$ in.

This is a plain paten, with a fluted moulding round the edge.

PEWTER PATEN. Diam. $6\frac{1}{8}$ in.

Mark underneath. A flower between I. B., with the date 1698 below, the whole within a circle.

This paten has a round moulding round the edge.

BRINGHURST.

SILVER CUP WITH COVER PATEN. Weight of cup 9.2 oz. Height 6 in. Diam. of bowl $3\frac{3}{4}$ in.; of foot $3\frac{3}{8}$ in. Height of stem $2\frac{3}{4}$ in. Date 1567. (PLATE 18)

Hall marks. 1. Small black letter K, with annulet below, in plain pointed shield. 2. Lion passant. 3. Leopard's head crowned, each of the two latter having an outside line following its outline. 4. A star of six points, somewhat irregularly stamped.

The bowl of this cup is an inverted truncated cone with a flat base, bulging out sides, and the lip a little bell-shaped. While the bowl has been left perfectly plain the stem and foot are more ornamented than usual. Just under the bowl is the egg and tongue ornament; below this, round the upper part of the stem, between horizontal lines, is a strip of lozenge-shaped lattice-work, underneath which is a disk $1\frac{1}{4}$ in. in diameter, divided into twelve parts by radii; through the end of each part a small hole has been bored close to the edge. Below this disk comes the main part of the stem, which is quite plain and round, swelling out towards the disk and the foot. Round the lower edge of the stem is a chain ornament, formed with a row of little circles. The foot has the egg and tongue ornament round its edge.

* *Archaeological Journal*, Vol. 43, pp. 147 and 368. † Ex. inform., Rev. G. C. Fenwicke. Messrs. Hardman can find no record of the repair in their books.

SILVER COVER PATEN with foot. Weight 3.6 oz. Diam. $4\frac{1}{2}$ in. Diam. of foot 2 in. Height of foot $\frac{7}{8}$ in. Date 1567. (PLATE 18.)

Hall marks as on the cup.

There is the usual little rim inside the paten round the edge. In the middle inside, are four circles one within the other. On the outside, round the top of the foot at its junction with the paten, is the egg and tongue ornament. This paten fits on to the cup both ways.

PEWTER BASIN. Diam. 9 in. Depth 1 in.

Marks. 1. B. C., for Brighthurst church, on the edge underneath. 2. X crowned. 3. In four small shields: (a) Lion's head erased. (b) Leopard's head crowned. (c) Britannia. (d) S. S. 4. Between two pillars, a hare supporting a garb, having "Samuel" above, "Smith" below. Underneath this is "Good mettle made in London."

GREAT EASTON.

SILVER PATEN. Weight 1.5 oz. Diam. $4\frac{1}{2}$ in. Date circa 1350. (FIG. 26.)

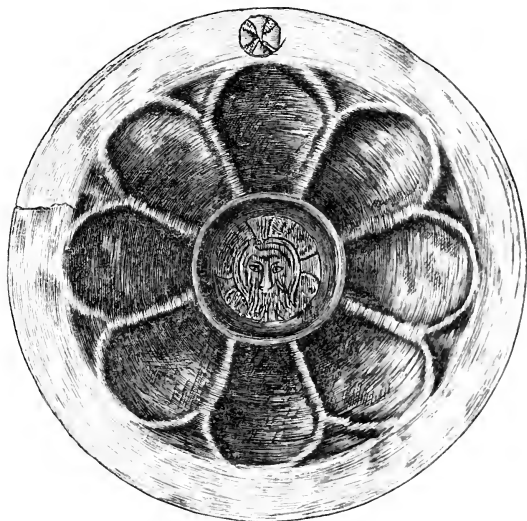

Fig. 26, circa 1350. Full size. M.P. del.

No hall marks.

This I take to be the oldest piece of church plate in use in this county. It does not exactly belong to any of the types so elaborately classified by Messrs. W. A. St. John Hope and T. N. Fallow,* for its shape is somewhat exceptional.

* *Archaeological Journal*, Vol. 43, pp. 151, 374.

It has a flat edge within which is sunk, not very deeply, an eight lobed-depression, the points of the lobes being extended till they meet a circular depression in the centre of the paten: within which is engraved the head of the Saviour upon a cruciform nimbus. Upon the edge of the paten, over the vernicle is engraved a small cross patée within a circle. This paten has been very rudely made; the centre points, from which the circle in the middle and the lobes have been described, are still visible; the centre point of the circle disfiguring the vernicle: the engraving also of the vernicle, and of the cross on the edge, is very unevenly done.

(a)

SILVER PATEN. Weight 6.1 oz. Diam. $7\frac{1}{8}$ in. Date 1684.

Hall marks. 1. Small black letter G in plain pointed shield. 2. Lion passant in a plain oblong. 3. Leopard's head crowned in a circle. 4. A bird with two pellets and a B above, within a shaped shield: the latter mark is indistinct.

This paten which is quite plain in shape, has this inscription underneath; "*Ex dono V. G. 84.*"

SILVER SPOON. Weight 2 oz. Length $7\frac{7}{8}$ in. Date 1686.

Hall marks. 1. Small black letter I in a plain shield. 2 and 3 as on last piece. 4. I. B. in a shaped shield.

This is a rat-tailed spoon with a wide bowl and a flat handle, ending in three points. Upon the back of the handle is engraved "V. G."

(b)

SILVER CUP. Weight 11.8 oz. Height $7\frac{3}{8}$ in. Diam. of bowl $3\frac{3}{8}$ in.; of foot 3 in. Height of stem $4\frac{1}{4}$ in. Date 1876.

This cup has a globular bowl, with a hexagonal stem, knob, and foot. Upon the bowl is engraved a cross bottonnée within a circle, and on the foot is the sacred monogram. Underneath the foot is "*A thankoffering from E. B. W. and F. W. Easter Day 1877.*"

SILVER PLATED FLAGON. Height $10\frac{1}{4}$ in.

This flagon is jug-shaped, with a cross for a knob on the lid.

PEWTER FLAGON. Height $12\frac{1}{4}$ in. Diam. of top 4 in.; of foot $5\frac{1}{8}$ in.
No marks.

This flagon is straight-sided in shape, narrowing towards the top, with a raised lid and R shaped handle.

There was formerly here a silver cup described by Archdeacon **Bonney** as an "ancient silver cup of Queen **Elizabeth's** time." This was sold a few years ago.

(a)

The silver paten inscribed "V. G." was presented to this church in accordance with this clause in **Valentine Goodman's** will made 31st Jan., 1684, and proved at Leicester in 1685; "*I give to Easton communion table a piece of plate of 40 shillings value.*" This gentleman sprang from a younger branch of the **Goodmans** of Blaston, being the second son of **Valentine Goodman** of that parish and his wife **Elizabeth**, daughter of **Abel Barker**, of Hambleton, co. Rutland;* he was baptized at Hallaton on 25th May, 1644. Mr.

* "Mr. Valentine Goodman and Elizabeth Barker, married 6th Jan., 1641-2;" Hambleton register. *Nichols*, in Vol. ii., p. 455, is incorrect in the pedigree of this family.

Valentine Goodman lived and died at Easton and was buried at his own request at Medbourne on 8th Feb., 1684-5.

Valentine Goodman who died unmarried, left a sum of £800 in the hands of these trustees; brother **Everard Goodman**, of Blaston, to be treasurer, uncle **Henry Green**,* of Rolleston and his son **Richard Green**, Sir **Tho. Barker**,† of Lyndon, co. Rutland, Bart., the present and future incumbents of Hallaton, Medbourne and Bringhurst, together with the successors of the then minister‡ of Blaston St. Giles; this money he ordered to be invested in land, and the income to be spent in the "relief and support of antient, lame, decrepitt, poor and indigent persons for ever;" six to be chosen out of Easton, four out of Medbourne, four out of Hallaton, and two out of Blaston. His brother **John Goodman**,§ sole executor and residuary legatee.

The arms of **Goodman** are: *Per pale Sable and Ermine an eagle displayed with two heads Or.*

The initials on the spoon tell that it also was bought with money formerly belonging to **Valentine Goodman**; perhaps with some small sum which was over after the trustees had invested his bequest to the poor, in the purchase of 88 acres of land in Drayton and Bringhurst parishes. ||

(b)

The modern cup is the gift of the present vicar of Bringhurst and Easton, the Rev. Canon **Edward Bower Whyley**, and his wife.

HALLATON.

SILVER CUP WITH COVER PATEN. Weight of cup 9.1 oz., including some lead in the stem. Height 6½ in. Diam. of bowl 3½ in.; of foot 3¼ in. Height of stem 2½ in. Date 1567. (PLATE 15.)

Hall marks. 1. Small black letter K, with annulet below, in plain shield. 2. Lion passant. 3. Leopard's head crowned, each of the two latter having an outside line following its outline. 4. A fleur-de-lis, in a shaped shield.

The bowl of this cup is an inverted truncated cone, with a small raised moulding running round it near the lip. The stem is of the usual evenly-balanced shape having a knob formed with a plain round moulding on a fillet, from whence it swells out at each end into a vertical edge, round which run a few lines. The foot is rounded off into a sloping edge.

SILVER COVER PATEN with foot. Weight 2 oz. Diam. 4 in. Diam. of foot 1½ in. Height of foot ¾ in. Date 1567. (PLATE 15.)

Hall marks as on the cup.

This paten which fits on to the cup both ways, has a flat edge, round the inside of which is the usual rim. The foot is a disk attached to the paten by a stem swelling out to both ends:

* H. Green married testator's aunt, Mary, daughter of Abel Barker. + His first cousin. † Humphrey Michel, who was not backward in entering in the parish register his supposed reason for his having been omitted, see *Nichols*, Vol. ii., p. 450. § His half-brother; the son of Elizabeth Goodman, who married secondly her first husband's brother, much against the will of her brother Sir Abel Barker, Bart. See Appendix to fifth *Report of Hist. MSS. Com.*, on p. 387, of which "Walter" is put by mistake for Valentine. || Changed at the Enclosure into the present farm of sixty-one acres; vide *Report of Commissioners on Charities*, Vol. xvii., p. 235.

a narrow moulding runs round the middle of the stem. Both cup and cover are entirely without ornament of any kind.

SILVER CUP. Weight 18 oz. Height $8\frac{7}{8}$ in. Diam. of bowl, of foot, and height of stem $4\frac{1}{4}$ in. Date 1735.

Hall marks. 1. Capital Roman V. 2. Leopard's head crowned. 3. Lion passant. 4. G. S.; probably the mark of *Gabriel Sleath*.

Upon the bowl of this cup, which is straight-sided in shape, there is the sacred monogram with a cross above and three nails below within a circle of glory; with this inscription underneath, "*All for the love of Jesus.*" The stem has a small moulding for a knob.

SILVER PATEN with foot. Weight 6.9 oz. Diam. $5\frac{1}{2}$ in. Diam. of foot 2 in. Height of foot $1\frac{1}{2}$ in. Date 1735.

Hall marks as on the cup.

The sacred monogram is engraved on the foot, and the inscription mentioned above underneath the paten.

SILVER DISH with foot. Weight 12.4 oz. Diam. $7\frac{7}{8}$ in. Diam. of foot $3\frac{3}{8}$ in. Height of foot $1\frac{3}{4}$ in. Date 1735.

Hall marks as on the cup, with the exception of the maker's mark being, R.B., the mark of *Richard Bayley*.

The sacred monogram and the same inscription are engraved in the centre of the dish.

SILVER ALMS DISH. Weight 12 oz. Diam. $9\frac{1}{2}$ in. Date 1735.

Hall marks as on the cup.

The sacred monogram and the same inscription are engraved in the centre of the dish.

SILVER FLAGON. Weight 69.7 oz. Height 13 in. Diam. of top $4\frac{1}{2}$ in.; of foot $7\frac{1}{2}$ in. Date 1735.

Hall marks as on the cup.

This large flagon is straight-sided in shape, narrowing towards the top, with a round top to the lid and a large round handle. The sacred monogram and the same inscription are engraved on the front of the drum.

The modern service was the gift of the Rev. **George Fenwicke**, B.D., the only son of the Rev. **William Fenwicke**, rector of Thackham, Sussex, then of Hallaton, (South Mediety,) and finally of Carlton Curliou, by his wife, **Cicely**, daughter of **Gilbert Coles**, D.D., rector of Easton, Hants, and was born at Hallaton on 11th Dec., 1689, and baptized on 9th Jan., 1690. He was sent to St. John's College, Cambridge, and from thence took his B.A. in 1708, M.A. in 1712, and B.D. in 1720, having been previously elected a fellow. Upon the resignation of his father in 1722, Mr. **G. Fenwicke**, was appointed rector of the South Mediety of this parish, being made rector of both Medieties when they were permanently united in 1728. He died rector of Hallaton, on 10th April, 1760.

In the churchyard of this parish against the North wall of the chancel, is a large monument, surmounted by an obelisk, to Mr. **Fenwicke's** memory, upon which is a short inscription, and at the top his arms; *Per fesse Gules and Argent six martlets counterchanged.* Mr.

Fenwicke published a visitation sermon in 1736; one on the small-pox in 1737; and two others in the year following. He was also the author of "The friendly monitor for rich and poor;" "Thoughts on the Hebrew titles of the Psalms;" and "The Psalter in its original Form."

He was married three times: first to **Mary**, the daughter of the Rev. Mr. **Nicholl**, of Preston Capes, Northants, who was buried in Hallaton church, on 8th Aug., 1726, leaving no issue: a tablet to her memory exists on the South wall of the chancel: secondly to **Alice**, the daughter of **John Hickman**, Esq., of Malpas, Cheshire, who was buried at Hallaton, on 5th Jan., 1738, and by whom he had two sons, **George**, who died in 1750, aged 22, and **John**, his successor in this living, and grandfather of the Rev. **Gerard Charles Fenwicke**, of Blaston manor, the head of the **Fenwicke** family: thirdly to **Elizabeth**, the daughter of the Rev. **John Yates**, rector of Ayston, Rutland, and widow of the Rev. **Thomas White**, rector of the same parish, and of Nailstone in this county, and also prebendary of Lincoln: this lady died on 3rd Jan., 1754, aged 66, and was buried in Ayston church, next to her first husband: to their memory Mr. **Fenwicke**, who had no issue by this his last wife, placed a marble monument on the South wall of the chancel of Ayston church.

In addition to making the gift mentioned under East Norton, the Rev. **G. Fenwicke** bequeathed two houses and some land in this parish, which at the enclosure were exchanged for a field of more than 16 acres, the income from which he devoted to the rector of Hallaton, the poor, and the school, giving over the use of one of the houses to three recipients of Mrs. **Parker's** charity.*

BLASTON ST. MICHAEL.

SILVER CUP. Weight 8.2 oz. Height 6 $\frac{3}{8}$ in. Diam. of bowl and of foot 3 $\frac{1}{8}$ in. Height of stem 3 in. Date 1735.

Hall marks. 1. Capital Roman V. 2. Leopard's head crowned. 3. Lion passant. 4. G.S.

This cup has a straight-sided bowl slightly bell-shaped, and a thick stem with a small moulding for a knob. Upon the bowl there is the sacred monogram, with a cross above and three nails below, within a circle of glory: underneath which is "*All for the love of Jesus.*"

SILVER PATEN. Weight 2.8 oz. Diam. 4 $\frac{1}{8}$ in. Date 1735.

Hall marks as on the cup.

This paten has also the sacred monogram and same inscription in the centre. Underneath there is a ring $\frac{1}{4}$ of an inch deep for a foot.

SILVER DISH. Weight 6 oz. Diam. 5 $\frac{3}{4}$ in. Date 1735.

Hall marks as on the cup.

The sacred monogram and same inscription is in the centre.

SILVER DISH. Weight 3.8 oz. Diam. 4 $\frac{7}{8}$ in. Date 1735.

Hall marks as on the cup.

The sacred monogram and same inscription is in the centre.

* *Vide* East Norton.

PEWTER FLAGON. Height 10 in. Diam. of top $3\frac{3}{8}$ in.; of foot $5\frac{1}{4}$ in. Date 1698. (PLATE 17.)

Marks. 1. On lid, three small lions rampant, each in a plain shield. 2. On the bottom inside, a conventional flower between I. B. and the date 1698, within a circle. 3. Four small lions rampant, each in a plain shield.

This flagon is straight-sided in shape, narrowing towards the top. Its lid is conical in shape. On the back of the handle is a band of ornament formed by a single row of lattice work, each lozenge containing a star. In front of the flagon is this inscription in script letters within an oval border; "*This Belongs to St. Michael's de Blaston.*"

This silver service of communion plate was given to Blaston St. Michael by the Rev. **George Fenwicke**, who gave at the same time the communion plate mentioned before, to Hallaton church. Mr. **Fenwicke** was rector of both parishes; this Blaston having been from time immemorial a chapelry of Hallaton.

HORNINGHOLD.

SILVER CUP. Weight 6.9 oz. Height $6\frac{1}{2}$ in. Diam. of bowl $3\frac{3}{8}$ in.; of foot $3\frac{1}{4}$ in. Height of stem $3\frac{1}{4}$ in. Date 1638.

Hall marks. 1. Court hand A on plain pointed shield, the A being placed backwards, with the back stroke on the left hand. 2. Lion passant. 3. Leopard's head crowned; each of these two having an outside line following its outline. 4. I.P. with a triangle below within a shaped shield, a pellet in each of the four corners.

The bowl of this cup is an inverted truncated cone, with the lip slightly bell-shaped. The stem is evenly-balanced, having a knob in the middle, formed by a round moulding on a fillet. The foot is of much the same shape as that of an Elizabethan cup.

SILVER PATEN with foot. Weight 2.3 oz. Diam. $4\frac{1}{8}$ in. Diam. of foot $2\frac{1}{4}$ in. Height of foot $\frac{7}{8}$ in. Date 1638.

Hall marks as on the cup.

This paten is quite plain in shape, having a flat rim $\frac{1}{2}$ an inch wide, the middle part within it being sunk. It has been made to fit on to the cup with the foot downwards and not as a cover.

PEWTER CUP with cover. Height of cup, with cover on it, $10\frac{3}{8}$ in. Diam. of top $5\frac{3}{8}$ in. Height of stem $3\frac{3}{8}$ in.

Underneath foot is "*James Dixon & Son, 36.*"

This is a large two-handled cup with stem and foot. It is used as a flagon and has two spouts, one on each side of the lip between the handles; the cover projecting in a corresponding way so as to cover the spouts.

In 1638 the principal landowner here, was **George Turpin**, of Knaptoft, who owned the old manor house still standing, near the church; in one of the upper rooms of which is a large shield bearing his quarterings. From him this house and property passed to his daughter **Elizabeth**, wife of Sir **John Pretzman**, Bart.

LODDINGTON.

SILVER CUP WITH COVER PATEN. Weight of cup 9.8 oz. Height $6\frac{3}{8}$ in. Diam. of bowl $3\frac{5}{8}$ in.; of foot $3\frac{1}{2}$ in. Height of stem $3\frac{1}{2}$ in. Date 1573. (PLATE 18.)

Hall marks. 1. Small black letter Q in a plain shield. 2. Lion passant. 3. Leopard's head crowned, each within an outer line. 4. F R in monogram, within a shaped stamp.

This cup has a bowl shaped into an inverted truncated cone, concave, with a flat base, round which is a band without curves, formed simply with two straps enclosing foliage. The stem is evenly-balanced, divided in half by a round moulding on a fillet: its vertical edges are reeded. The foot is rounded off into a flat edge on which is the egg and tongue ornament. Under the band on the bowl is engraved "*Loddington Church*" in Roman capitals: this was done at the time the later pieces were given.

SILVER COVER PATEN with a foot. Weight 2.3 oz. Diam. $3\frac{7}{8}$ in. Diam. of foot $1\frac{3}{8}$ in. Height of foot $\frac{7}{8}$ in. Date 1573. (PLATE 18.)

Hall marks as on cup.

This paten has a flat edge with the usual rim, from whence it is sunk in a flat round. The foot is a disk attached to the cover by a stem swelling more to the paten than to the foot. Upon the latter is engraved in Roman capitals "*Ano Domini, 1574.*" The letters are ornamented with a zigzag line.

SILVER PATEN with a foot. Weight 6.3 oz. Diam. $6\frac{1}{4}$ in. Diam. of foot $2\frac{5}{8}$ in. Height of foot $1\frac{3}{4}$ in. Date 1708.

Hall marks. 1. Court-hand M. 2. Lion's head erased. 3. Britannia. 4. W. A., a pellet between the letters, a bee-hive above, within a trefoil.

This is a flat paten with a small raised edge. Its foot is hollow, having a stem $1\frac{1}{4}$ in. thick swelling out at both ends. In the centre of the paten is this crest: *A tower proper, enflamed of the last, Morris.* (FIG. 27.) Round the crest is "*Ex dono Caroli Morris, Anno Domini, 1709.*" Below is "*Loddington Church.*"



Fig. 27.

SILVER FLAGON. Weight 27.3 oz. Height $8\frac{3}{4}$ in. Diam. at the top $3\frac{3}{4}$ in.; at the foot $5\frac{1}{8}$ in. Date 1705.

Hall marks. 1. Court-hand K. 2. Lion's head erased. 3. Britannia. 4. R, a bird below, within a shaped shield. Mark of *Andrew Raven.*

This is a straight-sided flagon narrowing towards the top, having a round top to its lid and the usual shaped handle. In front is "*Given by Edmund Morris, Gent: eldest son to Charles Morris, Esquire, to the parish church of Loddington. Anno Dni., 1706.*"

Charles Morris, the donor of the paten, was the eldest son of Captain Robert Morris, of the city of London, by Margaret, second daughter of Edmund Smith, Esq., of Annables, Hertfordshire, and was born on 5th Sep., 1662. This gentleman inherited the manor of Loddington from his father in 1675-6, a certain John Morris having bought it in about 1670 from the trustees of Sir John Pretyma, 2nd Bart. Charles Morris was buried at Loddington on 25th March, 1710. (Will proved at Leicester 1710.) He

married in 1685 * **Susannah**, third daughter and co-heir of Sir **Edmund Bacon**, 4th Bart., of Redgrave, Suffolk, by **Elizabeth**, daughter and co-heir of Sir **Robert Crane**, Bart., of Chilton, Suffolk; this lady was buried at Loddington on 28th March, 1717, having had issue, three sons. (Will proved at Leicester 1717.)

The donor of the flagon was the eldest son of the above **Charles** and **Susannah Morris**, and was born in 1687. **Edmund Morris** was M.P. for Leicestershire in 1722, and high sheriff in 1746. He was buried at Loddington on 30th July, 1759. (Will proved P.C.C. 1759.) He married *circa* 1720 **Anne**, the second daughter of Sir **Alexander Campbell**, of Calder, by **Elizabeth** his wife. This lady died at Greenwich, and was buried at Loddington on 14th Sep., 1775.

Edmund and **Susannah Morris** had five daughters and one son, **Charles**, from whom is descended **Charles Henry Morris**, who sold the Hall estate in this parish some years ago. It is now owned by Lord **Morton**.

No monument was erected in this church to either **Charles** or **Edmund Morris**, but portraits of both father and son are in the possession of one of their descendants, Mrs. **Phillips**, of Fernleigh, Leicester, at the present time. The arms of **Morris** are; *Sable a lion passant Or, between three scaling ladders, Argent.*†

MEDBOURNE.

SILVER CUP WITH COVER PATEN. Weight of cup 12.5 oz. Height $7\frac{1}{2}$ in. Diam. of bowl $3\frac{3}{4}$ in.; of foot $4\frac{1}{4}$ in. Height of stem $3\frac{1}{4}$ in. Date 1701. (PLATE 17.)

Hall marks. 1. Court-hand F. 2. Lion's head erased. 3. Britannia. 4. B.R., in heart-shaped shield. Mark of *Moses Brown*.

This cup has a straight-sided bowl with a slightly bell-shaped lip and a flat base. The stem, which has a plain round moulding for a knob, swells out into a plain foot. Upon the bowl is "*Midbourn Communion Cup, 1701.*" The weight 19 oz. 16 dwts., is engraved beneath the foot, which weight includes the cover.

SILVER COVER PATEN with foot. Weight 7.1 oz. Diam. $4\frac{3}{8}$ in. Diam. of foot $2\frac{1}{4}$ in. Height of foot $1\frac{1}{8}$ in. Date 1701. (PLATE 17.)

Hall marks as on the cup.

This cover has a flat edge, the middle of the paten being deeply sunk. On the foot is the same inscription. Both the cup and the cover, especially the latter, are very solidly made. The cover fits on to the cup both ways.

(a)

SILVER PATEN. Weight 13.6 oz. Diam. 8 in. Date 1835.

London hall marks.

Underneath this plain paten is "*Medbourn. The gift of Rev. L. P. Baker, Rector of the said parish, 1835.*" and weight 13 oz. 12 dwts.

* Licence dated 10th June. *Pub. Harl. Soc.*, Vol. xxiv. † For pedigree see *Leicestershire Pedigrees and Royal Descents*. W. G. D. Fletcher, p. 177.

(b)

SILVER DISH with foot. Weight 16.7 oz. Diam. $7\frac{3}{8}$ in. Diam. of foot 3 in. Height of foot 1 in. Date 1835.

London hall marks.

In the centre of this dish is the sacred monogram within a circle of glory, and on the foot "*Medbourn. The gift of Elizabeth Hodgson, aunt of the Rev. L. P. Baker, Rector of the said parish. 1835.*" Underneath is also the weight 16 oz. 15 dwts.

PEWTER PLATE. Diam. $8\frac{1}{4}$ in.

A portion of "London" is the only mark now visible on this plate.

TWO PEWTER FLAGONS. Height of each 10 in. Diam. at top $2\frac{3}{4}$ in.; at foot 5 in.

Mark. Near the purchase L.S. repeated twice; these initials are apparently only part of the mark, the rest being quite obliterated.

These flagons are straight-sided, narrowing towards the top. Each has a plain round handle, and a flat top to its lid.

Nothing certain can be said about the origin of the silver cup and cover.

(a)

The Rev. **Lawrence Palk Baker**, was the son of **John Baker**, surgeon, of Buntingford, by **Mary**, eldest daughter of the Rev. **Jonathan Gilder**, rector of Aspenden, Herts, and was baptized at Buntingford on 10th Nov., 1783.* He matriculated as sizar into St. John's Coll., Camb., on 17th Dec., 1803, from whence he took his B.A. degree in 1807, M.A. 1810, S.T.P. 1817; he was for some years a fellow of his college; by which in 1825 he was presented to the rectory of Medbourne with Holt. Here Mr. **Baker**, who was unmarried, lived and worked, respected both by parishioners and neighbours, till his death in 1870; shortly before which he had presented the church in his parish with school buildings. He was buried in this churchyard on 5th Feb.

In his will made 11th May, 1850, and proved with two codicils, on 7th April, 1870, at Leicester, the Rev. **L. P. Baker** bequeathed legacies to the only daughter of his brother, Lieut.-Col. **William Thomas Baker**; to his brother **John Law Baker**† and latter's three daughters; to **Emma Louisa Sarah**, wife of **Dennis Walker**: also £100 consols to rector and churchwardens of Medbourne, £2 a year out of the interest to be devoted to the repair of the church clock, and surplus to the church school.

(b)

Elizabeth Hodgson was aunt to Mr. **Baker** since she was a daughter of the Rev. **J. Gilder**, rector of Aspenden, by **Mary** his wife; she married, as his second wife, Mr. **Christopher Hodgson**, banker; after whose death she lived here for the rest of her life, for some twenty-five years, with her nephew. Mrs. **Hodgson** died here, leaving no issue, in 1850, aged 91, and was buried in this churchyard.

* Parish Register. † Whose eldest son is Lawrence James Baker, Esq., of Ottershaw Park.

NEVILL HOLT.

SILVER CUP. Weight 18 oz. Height $8\frac{1}{2}$ in. Diam. of bowl and of foot $4\frac{1}{2}$ in. Height of stem $3\frac{3}{4}$ in. Date 1641. (PLATE 17.)

Hall marks. 1. Court hand D in a plain shield. 2. Lion passant. 3. Leopard's head crowned, each of the two last having an outer line following its outline. 4. P. B. a crescent above and below, the points of both turned towards the letters, within a shaped shield.

This is a strong cup, made of thick metal. The shape of its bowl is an inverted truncated cone with a flat base and a raised lip. Its stem is evenly-balanced, being divided in half by a large round knob, and swelling out at both ends. The foot is plain, with a few small mouldings running round its edge. Underneath is a plate, covering perhaps some lead inside the stem; upon which is the lion passant. On the bowl are these arms; *Quarterly, 1 and 4, Gules, a saltire Ermine; Nevill of Raby; 2 and 3. Or, fretty Gules, on a canton per pale Ermine and of the field a ship with three masts, sails furled, Sable; on the fesse point a mullet for a difference, Nevill.* Crest: *on a wreath Gules and Ermine, a bullock's head erased Ermine armed Or, gorged with a ducal coronet Vert.* The coat of arms divides, in half this inscription; "*The gift of Sr. Thomas Nevill, Kt.*"

SILVER PATEN with a foot. Weight 6.3 oz. Diam. $6\frac{3}{8}$ in. Diam. of the foot $2\frac{3}{4}$ in. Height of foot 1 in. Date 1641. (PLATE 17.)

Hall marks as on cup.

This paten has a flat edge 1 inch wide, the middle part being sunk flat $\frac{1}{8}$ inch in depth. The foot, in which is a crack, is a disk attached to the paten by a round stem 1 in. thick, swelling out at both ends. Underneath the foot, within a laurel wreath, is engraved the Nevill crest on a large scale.

GLASS FLAGON with silver fittings. Height 8 in. Date 1881.

London hall marks.

This is a small glass jug-shaped flagon with a silver handle, top, and lid; the latter being surmounted with a cross.

Since the cup and paten were made some years after the donor died, they were bought I have no doubt with part of a certain sum of money left by Sir **Thomas Nevill**, *alias Smyth*, Knt., to Holt Church in the following clause in his will, dated 11th Jan., 1630, and proved 11th March, 1635-6, P.C.C.; "*To repair Holt church £40 to be bestowed as occasion shall serve.*" Sir **Thomas Nevill**, was the third son of **Thomas Smyth** of Cressing Temple, co. Essex, by **Mary**, only child of Sir **Thomas Nevill**, Knt., of Holt,* the direct representative of the branch of the ancient family of **Nevill** which had been long seated in this place. Upon his marriage with **Mary Nevill**, **Thomas Smyth** took his wife's name, which was also adopted by his two eldest sons, and by his eventual heir, Sir **Thomas**; the donor of this cup and paten.

Sir **Thomas Nevill**, *alias Smyth*, was born at Cressing Temple on 14th June, 1555.† He was high sheriff of Leicestershire in 1606. Owing to his

* Visitation of Leicester, 1619. *Harl. Soc.*, Vol. ii., p. 21.

† White Notley parish register.

elder brothers **Clement** and **Henry Nevill**, and his younger brother, **William Smyth** dying without issue, **Sir Thomas Nevill** ultimately became a very large landed proprietor. In addition to the manors of Holt and Drayton, with lands in Medbourne, Presgrave, Bradley, Brighthurst and Easton in this county; he came into property in Cressing Temple, White Notley, Witham, Redfauns, Langford, and Black Notley, co. Essex, and also into valuable estates in co. York. In 1635 **Sir Thomas** built the porch to Holt church, in front of which is an inscription to that effect. He died on 2nd March, 1636, and was buried in Holt church; at the East end of the South transept is a table monument of alabaster supporting his recumbent effigy, above which against the wall, are pilasters and panelling bearing an inscription* and the same arms and crest as those on the cup. **Sir Thomas Nevill** was twice married; first to **Jane**, eldest daughter of **Toby Haughton**, Esq., of King's Cliffe, Northants, and Kelthorpe, Rutland, by whom he had six sons and three daughters; secondly to **Elizabeth**, widow of **Sir John Ferne**, Knt., of Temple Belwood, co. Lincoln, and daughter of **John Needham**, Esq., of Wymondley Parva, Herts, which lady was buried at Holt on 17th Dec., 1629. **Sir Thomas** was succeeded by his eldest son Col. **Henry Nevill**, a noted Royalist, whose estates were much impoverished and diminished through his fidelity to that cause; from him was descended in the female line the late **Charles Nevill**, Esq., whose son **Cosmas C. G. Nevill**, sold Holt to Mr. **Henry John Grieseson**, from whom it was purchased by Mr. **Edward Cunard**; at whose death in 1877, Nevill Holt passed to his eldest brother, **Sir Bache Cunard**, Bart.

In addition to the above-mentioned bequest to Holt church, **Sir Thomas Nevill** left £10 to the poor of this parish, and £2 each to Drayton, Easton, and Hallaton, for their poor. Sums of various amounts were left to his four younger sons, **William, Thomas, Nevill, and Clement Smyth**.†

SKEFFINGTON.

SILVER CUP WITH A COVER PATEN. Weight of the cup 10.4 oz. Height 8 in. Diam. of the lip $3\frac{1}{2}$ in.; of the foot $3\frac{1}{4}$ in. Height of stem 4 in. Date 1605. (PLATE 17.)

Hall marks. 1. Lombardic H in a plain pointed shield. 2. Lion passant. 3. Leopard's head crowned, each of the two last having an outer line. 4. H. S., a garb below, within a shaped shield.

The bowl of this cup in its lower part is nearly straight-sided; half way up it swells out gradually into a bell-shaped lip. The bowl ends in a flat base, which rests upon a very well

* For which, see *Nichols*, Vol. ii., p. 729. † So named in the will: In the *Visitation of London 1634*. Thomas, the third son, draper, has arms and name of Nevill.

shaped baluster stem. The foot is flat and sloping, with a few small mouldings running round its edge. Upon the bowl is, "*Ex dono dominæ Katherine Skeffington 1606*;" underneath the foot is, "*it wayes xiiii oz. ii d. wtt at vs. 8d. a oz. it comes to iiiiil.*"

SILVER COVER PATEN with a foot. Weight 3.8 oz. Diam. $3\frac{3}{8}$ in. Diam. of foot $1\frac{3}{4}$ in. Height of foot $1\frac{1}{8}$ in. Date **1605**. (PLATE 17.)

Hall marks as on cup.

This paten has a flat edge on which is fixed the usual rim. The foot is a disk attached to the paten by a round stem swelling out at both ends. Round the edge of the foot is the same inscription as that on the cup; a cross potent being placed between the first and last words.

SILVER FLAGON. Weight 15.7 oz. Height $10\frac{3}{4}$ in. Diam. at the top $2\frac{1}{4}$ in.; at the foot $3\frac{3}{8}$ in. Date **1870**.

London hall marks.

This is a jug-shaped flagon, good and plain; the only ornament upon it being the sacred monogram within a quatrefoil in front. Its lid is surmounted with a cross. The handle terminates at each end in a trefoil. Underneath the foot is "A.D. 1871."

SILVER PLATED PATEN with a foot. Diam. 6 in. Diam. of foot $2\frac{3}{4}$ in. Height of foot $1\frac{7}{8}$ in.

This is a perfectly plain paten with a raised edge and a hollow foot.

PEWTER FLAGON. Height 12 in. Diam. at the top $4\frac{1}{2}$ in.; at the foot 7 in.

No marks.

This is a straight-sided flagon narrowing to the top, having a flat top to its lid. Underneath the foot is engraved "I. W."

PEWTER PLATE. Diam. $9\frac{1}{4}$ in.

Mark. 1. "S. Church." 2. On an oval shield, a chevron engrailed between three eagles' heads erased. 3. On a scroll, "London."

This is a plain plate with a flat edge 1 in. wide.

The donor of the cup and cover was **Katherine**, the eldest daughter of Sir **Richard Chetwode**,* Knt., of Chetwode, co. Bucks, and of Warkworth, co. Northants, by his first wife **Margaret Jane**, daughter and co-heir of Sir **William Drury**, Knt., sometime Deputy-Lieutenant of Ireland, and was born in about 1580.† She married Sir **William Skeffington**, Knt., of Skeffington, of Arley, Warwickshire and of Datchurch, Kent. This gentleman, who was knighted at Belvoir, on 23rd April, 1603, was the representative of the elder branch of this ancient family, settled in this parish from the time of **Edward I**. He died without issue on 19th Dec., 1605, aged 25.

Sir **William Skeffington**, by will dated 13th June, 1604, and proved P.C.C. 3rd Feb., 1605-6, left to his wife **Katherine**, all his manors, messuages, and lands in Stoke Rochford,

* For pedigree, see *Miscell. Genral. et Herald*, Vol. i., 2nd series, pp. 69 and 85. † " — Chitwoode the daughter of Mr. Richard Chitwoode, was baptized the 17th of Nov., 1583." Chetwode parish register.

Easton and Obthorpe, co. Lincoln; and in Stokeham, Little Markham, Great Markham, Darleton, North Leverton, Keyton, Dunham and Drayton, or elsewhere in co. Nottingham. These estates he left to his wife as an addition to her marriage settlement, which was a charge of £120 a year on the manor of Skeffington, the proceeds of the rectory of Billesdon and the advowson of the vicarage of that parish. Lady **Skeffington** residuary legatee and sole executrix.

From **Burton** we learn that Sir **William Skeffington** was "a knight of good estate and worth, but too much possessed with an Italian humour (*la gelosia*); that he would not vouchsafe his wife, **Katherine**, scarce to see or to be seen, to converse or be conversed withall, though she was a lady of many worthy parts, well qualified, and of great desert." Perhaps this excessive watchfulness had the not unusual result of weakening the lady's power of taking care of herself, for, after Sir **William's** death, lady (**Katherine**) **Skeffington** took such a liking to **Michael Bray**, a groom in her service, that she married him. This mésalliance caused so much ill-will between this lady's second husband and **John Skeffington**, Sir **William's** brother and heir, that at last they entered into a suit in chancery. Both parties being at Westminster for the trial, some friends persuaded them to meet at the Hoop Tavern, in Gray's Inn, to try and settle their differences. A speedy end to the quarrel was the result, for the groom standing at the bottom of the stairs with his sword ready drawn, stabbed Mr. **Skeffington** as he came down, he having just time before his death to draw his sword and kill his adversary. The date of their deaths was the 4th Nov., 1613.*

The donor of this piece of plate had four children by her second husband **Michael Bray**; **Richard**, **Giles**, **Elizabeth** and **Anne**. She was said to be living in 1650.†

The silver flagon was purchased with money from the offertory fund during the incumbency of the late rector, the Rev. **J. C. Davenport**.

STOCKERSTON.

SILVER CUP. Weight 5.4 oz. Height $5\frac{1}{8}$ in. Diam. of bowl and of foot $3\frac{1}{4}$ in. Height of stem 1 in. Date 1669. (PLATE 18.)

Hall marks. 1. Capital old English M in pointed shield. 2. Lion passant. 3. Leopard's head crowned; each of these two has a line following its outline. 4. W. D. with a rose and two pellets below, in a pointed shield.

This cup, unusually deep, has a bowl in shape an inverted truncated cone, with bulging out sides and a lip slightly bell-shaped. A cable moulding runs round the flat base of the bowl. The stem is a plain, short round one, swelling into a flat foot, under which the lion passant is repeated.

PLATED PATEN. Diam. 6 in.

This modern paten has the sacred monogram in the centre and a cross on its edge.

In 1669 Sir **Thomas Burton**, Knt., was owner of this lordship.

* See *Nicho's*, Vol. ii., p. 434. † *Shaw's Hist. of Staffs.*, Vol. i., p. 372.

TUGBY.

SILVER PATEN. Weight 1.8 oz. Diam. $4\frac{1}{2}$ in. Date *circa* 1480. (FIG. 28.)
No hall marks.

This prerformation paten can be classified more readily than the one at Great Easton* in accordance with the rules laid down by Messrs. **W. H. St. John Hope**, and **T. N. Fallow**; for it plainly belongs to the "Type D" of their list, being very similar to several described by

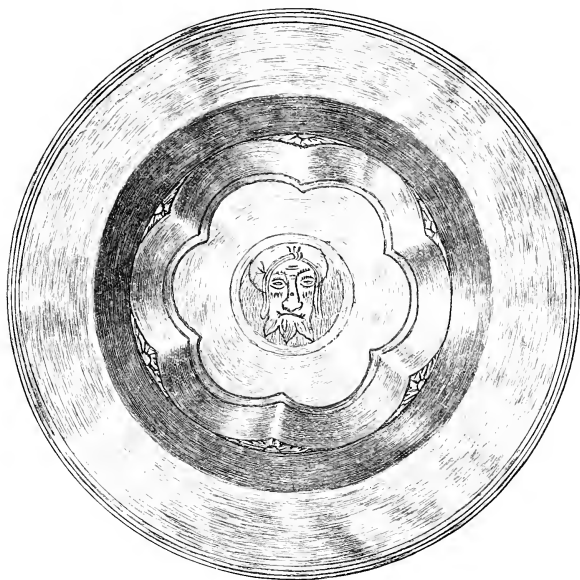

Fig. 28, *circa* 1480. Full size. M.P. del.

them under that head. It is sunk in two depressions, the lower one of which is sexfoil with spandrels filled with engraved foliage. In the centre within two circles is the vernicle rudely engraved. Three engraved lines run round the edge of the paten; this together with the spandrels and vernicle show traces of former gilding. Underneath the paten the weight 1 oz. 17 dwt. was roughly scratched in 1777.

SILVER CUP. Weight 5.3 oz. Height $5\frac{3}{4}$ in. Diam. of bowl $3\frac{3}{4}$ in.; of foot $2\frac{1}{2}$ in. Height of stem $2\frac{1}{4}$ in. Date *circa* 1570. (PLATE 18.)

* *Vide* p. 235.

One mark only, the leopard's face, with an outside line following its outline.

This cup is smaller than, but otherwise very like the one in the next parish of Alexton, made by the same maker.* Its bowl is nearly straight-sided in its lower-part, swelling out a little into a bell-shaped lip. The stem which is without a knob, swells out towards its upper and lower ends, round which are drawn five or six lines. The foot is of the usual Elizabethan shape, with the egg and tongue ornament round its edge.

(a)

SILVER SALVER. Weight 18.2 oz. Diam. $9\frac{1}{2}$ in. Date 1729.

Hall marks. 1. Capital Roman O in plain pointed shield. 2. Leopard's head crowned in rounded shield. 3. Lion passant in plain oblong. 4. E. C. in an oval: the mark of *Edward Cornock*.

This is a salver with three feet, and was evidently originally a piece of secular plate belonging to **Dorothy Wilson**, of Knightthorpe. Since it was given to this church it has been used as a paten. In the centre is this coat of arms;† *Sable, a wolf salient Or, in chief a fleur-de-lis of the last between two bezants; Wilson; impaling a chevron between three rams' heads erased; Chester, of Chicheley.* (FIG. 29.)



Fig. 29.

SILVER BASIN. Weight 14.1 oz. Diam. $9\frac{1}{4}$ in. Depth $1\frac{1}{8}$ in. Date 1735.

Hall marks. 1. Capital Roman V in pointed shield. 2. Leopard's head crowned in pointed shield. 3. Lion passant in an oblong. 4. Indistinct maker's mark.

This is a plain-shaped basin, having on its edge, "*Tugby Church plate, 1735, D.W.*"

(b)

SILVER FLAGON. Weight 34.5 oz. Height $10\frac{1}{8}$ in. Diam. at top $3\frac{1}{4}$ in.; of foot $5\frac{1}{8}$ in. Date 1730.

Hall marks. 1. Capital Roman P in pointed shield. 2. Leopard's head crowned in pointed shield. 3. Lion passant in a plain oblong. 4. I. S., with a pellet between, within a dotted oval: the mark of *Joseph Smith*.

This flagon is straight-sided in shape, narrowing towards the top, having a round top to its lid. In front is, "*Church plate of Tugby Leicestershire, 1730.*"

(c)

SILVER CUP. Weight 8.7 oz. Height 8 in. Diam. of bowl and of foot $3\frac{1}{2}$ in. Height of stem $4\frac{1}{8}$ in. Date 1848.

London hall marks.

Upon the bowl of this plain cup is the sacred monogram, with a cross above and three nails below, within a circle of glory; and also "*Tugby Church, 1849.*"

* Page 228. † The arms of this family as granted in 1467 are; *Per pale Argent and Sable a chevron engrailed between three rams' heads erased attired Or all counterchanged within a border engrailed bezanté.* Mr. Chester Waters tells us that the 4th Bart., Dorothy Wilson's brother, discontinued the border. This salver seems to point to other modifications having been made by this family in their arms.

On the cover of one of the registers of this parish is an inventory of the communion plate made 25th March, 1777, a copy no doubt of the one sent into Archdeacon **Bickham**. This is repeated in the terrier at Lincoln made in 1821, in both lists the service is the same as the present one, with the exception of the modern cup.

(a)

The salver and the silver basin were given by **Dorothy Wilson**, who in the same year (1735) presented a flagon to the church of her native parish of Chicheley, and also gave communion plate, probably at the same time, to Loughborough church.* This lady was the 9th of the 16 children of Sir **Anthony Chester**, 3rd Bart., by **Mary**, only daughter of Alderman **Samuel Cranmer**, of Astwoodbury, Bucks, the descendant of the Archbishop's eldest brother, and was born at Chicheley, on the 10th Aug., 1667, and baptized on the 19th.† **Dorothy Chester** was married at Chicheley in 1701, to **John Wilson**, Esq., of Knight-thorpe, co. Leicester, as his second wife. This gentleman was the fourth son of **Robert Wilson**, of Merton, the head of the family, and the purchaser of Knight-thorpe and Didlington, co. Norfolk. **John Wilson's** first wife was **Mary**, the daughter of Sir **Edward Walpole**, K.B., of Houghton, co. Norfolk, whom he married‡ in 1684, and who died on the 15th June, 1686, aged 21. Mr. **Wilson** himself died, having had no issue by either wife, on the 21st May, 1718, aged 59, and was succeeded by his elder brother **Edward**, ancestor of the late Lord **Berners**. **Dorothy Wilson** passed her long widowhood, "marked by many acts of charity and piety," at Knight-thorpe, left to her for life. She died there on 21st Nov., 1754, and was buried on the 27th by the side of her husband and his first wife in the sanctuary of Loughborough church.

The two slabs placed over their graves are now in the churchyard near the rectory garden; they, with most of the others in the floor of the church, were removed outside at the restoration of the church in 1862, some being placed in the tower.§

Dorothy Wilson was connected with Tugby, through her husband, who was first cousin to **Robert Wilson** of Keythorpe, and his sister **Catherine Parker**, the children of **Thomas Wilson**, purchaser of Keythorpe, a younger brother of **Robert**, purchaser of Knight-thorpe.

(b)

The flagon was presented to this church in the year that Mrs. **Catherine Parker** came to live at East Norton, so that it is not unlikely but what that benevolent lady defrayed a considerable share of the cost of this gift. Her brother, **Robert Wilson**, was then owner of Keythorpe and of most of the parish of Tugby.||

* Page 45. † *The Chesters of Chicheley*, Vol. i., p. 356, by R. E. Chester Waters. ‡ *Harl. Soc. Publications*, Vol. 24, p. 171. § For inscriptions, see *Nichols*, Vol. iii., p. 902. || Page 252.

(c)

The modern cup was the gift of **Mary Letitia Lady Berners**. This lady was the eldest daughter and co-heir of Colonel **George Crump**, of Alexton Hall, by his wife, **Mary Letitia**, third daughter of **Henry William Wilson**, Esq., of Didlington, Norfolk, the representative of the eldest branch of the family of **Wilson**. **Mary Letitia Crump** was born in 1800, and married at Alexton on the 24th of Feb., 1823,* her first cousin, **Henry William Wilson**, the eldest son of the Rev. **Henry Wilson**, rector of Didlington, and of Alexton. In 1838 the latter gentleman succeeded his elder brother, **Robert**, in the title of Lord **Berners**, inheriting the family estates in Norfolk, and also the Leicestershire property, which latter had been left to **Robert Wilson** by his distant cousin, **William Wilson**, of Keythorpe, and Alexton, the last male member of that younger branch of the family. The Rev. **Henry Wilson**, Lord **Berners**, dying in 1851, his eldest son, the Hon. **Henry William Wilson**, the husband of the donor of this piece of plate, succeeded to the title and estates. Lord **Berners**, a nobleman much valued by all the neighbourhood, lived for many years at Keythorpe Hall which he had rebuilt; always taking a lively interest in the management of his estates and in the welfare of the county. His wife **Mary Letitia, Lady Berners**, died on the 30th Sept., 1856, and was buried at Tugby on 4th Oct.† Lord **Berners** married secondly on the 21st July, 1857, **Henrietta Charlotte**, only daughter of the 1st Lord **Delamere**. His lordship died without issue on the 27th June, 1871; his second lady surviving him till the 13th of Aug., 1874.

Their memory is recorded in Tugby church by two white marble mural monuments enclosed in black marble Oxford frames, affixed to the South wall of the chancel. In memory of the first **Lady Berners**, the East window was filled with painted glass, a brass plate being placed on the sill to record the fact. Lord **Berners** was succeeded in his title by his niece, **Emma Harriet**, wife of Sir **H. T. Tyrwhitt**, Bart., present Baroness **Berners**, the daughter of the late Rev. the Honble. **Robert Wilson** by his cousin, **Harriet**, second daughter of Col. **G. Crump**. **Lady Berners** eldest son, the Hon. **Harry Tyrwhitt Wilson** is the present owner of Keythorpe.

EAST NORTON.

SILVER CUP. Weight 9.2 oz. Height 8 in. Diam. of bowl 4 in.; of foot 3½ in. Height of stem 4 in. Date 1742.

Hall marks. 1. Small Roman G in shaped shield. 2. Leopard's head crowned in shaped shield 3. Lion passant in shaped oblong. 4. F. S. with a crown above, within an ornamental shape; the mark of *Francis Spilsbury*.

This cup has a straight-sided bowl with a bell-shaped lip, and a plain round stem with a shallow moulding for a knob. On the bowl is "East Norton communion plate 1742." Under the foot the weight 9 oz. 5 dwt. is engraved.

* Parish Register.

† Parish Register.

(a)

SILVER PATEN. Weight 3.7 oz. Diam. 6 in. Date 1865.

London hall marks.

In the centre of this plain paten there is the sacred monogram, and underneath "*Thomas Norris, B.A., Dono Dedit A.D., 1864.*"



Fig. 30.

Wilson, the bearings in chief being omitted, by mistake probably of the engraver (FIG. 30.) Below the arms is "*The gift of Mrs. Catherine Parker, to the church of East Norton, 1739.*"

(b)

SILVER FLAGON. Weight 36.5 oz. Height 10 $\frac{5}{8}$ in. Diam. of top 3 $\frac{3}{4}$ in.; of foot 6 $\frac{1}{2}$ in. Date 1738.

Hall marks. 1. Capital Roman C in pointed shield. 2. Leopard's head crowned in shaped shield. 3. Lion passant in shaped shield. 4. F S with a pellet between and some mark below, within a heart-shaped shield. The mark of *Francis Spilsbury*; entered 1729.

This is a straight-sided flagon narrowing towards the top. It has a round top to its lid and a plain round handle. In front is this coat of arms: *Sable, a stag's head caboshed between two flanches Argent; Parker: impaling*

(c)

SILVER ALMS DISH. Weight 15.2 oz. Diam. 9 $\frac{1}{2}$ in. Date 1831.

London hall marks.

This alms dish is quite plain in shape; having in the centre the sacred monogram, with a cross above and three nails below, within a circle of glory; and on the back: "*In memory of Mary Letitia Baroness Berners, who died Sept. 30th, 1856.*"

PEWTER PLATE. Diam. 10 $\frac{1}{2}$ in.

Marks. 1. On the edge, W. T. E. 2. In three shaped squares. (a) Lion rampant. (b) Leopard's head crowned. (c) A mark like an O bisected by a horizontal line. 3. Underneath: a harp, with I. F. above, within a circle.

This is an interesting old pewter plate, made evidently for a paten; which was the use to which it was put to until the silver paten was given. It is flat in shape, having a broad flat edge, the middle part being sunk to the depth of about $\frac{1}{4}$ of an inch and 5 $\frac{1}{4}$ in diameter. It is very similar to the one of silver given in 1652 to Alexton.*

(b)

The donor of the flagon, and also very possibly of the cup, was **Catherine**, the only daughter of **Thomas Wilson**, Esq., merchant, of London, and purchaser of Keythorpe,† by **Anne**, daughter of **Christopher Packe**, Esq., of Prestwold, Lord Mayor of London. **Catherine Wilson** was born in 1666 and married **Charles Parker**, Esq., of Peterborough, as his second wife, the son, as I believe, of **Samuel Parker**, gent. of Peterborough, by **Mary Armstead**, of Thirsby, co. Lincoln.‡ Mr. **Parker** was one of the

* Page 228. † For pedigree of Wilson, see *Nichols*, Vol. iii., p. 514; he was younger brother of Robert Wilson of Merton, purchaser of Knight-thorpe. ‡ Married at Tickencote in 1661, *Blore's Rutland*, p. 74.

principal inhabitants of Peterborough, being lessee under the Bishop, of Burghberry manor. His signature appears first amongst the feoffees signing the minute book relating to the town charities, and in 1708 he was elected to be one of the Members of Parliament for that city. He died on the 25th of Feb., 1730, and was buried in Peterborough Cathedral, on 3rd March, by the side of his first wife **Catherine**, who had died on 21st Sep., 1708, and had been buried on the 23rd in the "South Cross isle" of that Cathedral.* This lady bore her husband several sons, who were baptized in the church of St. John the Baptist, Peterborough.† After her husband's death, the second Mrs. **Catherine Parker** lived in the old manor-house in East Norton, now pulled down, where she died, having had no issue, on the 2nd of July, 1747; she was buried in the chancel of Tugby church; against the North wall of which is a monument to her father and mother, three of her brothers, and herself.

In her will, dated 31st May, 1746, and proved P.C.C. 10th March, 1747-8, Mrs. **Parker** bequeathed sums of money to various charitable objects, £1000 to the Society for the Propagation of the Gospel; £50 to the Society for Promoting Christian Knowledge; £60 in trust to her step-son **Armstead Parker**, Esq.,‡ the interest to be spent by him in giving coals or bread to the poor in the respective parishes of Peterborough; £15 to the poor of Cranoe; £5 each to the poor of Uppingham, Goadby, Hallaton, Billesdon and Clapham, Middlesex; £2 to poor of Tugby; £100 to apprentice and clothe ten poor boys chosen by her executors, two being taken out of both Uppingham, Cranoe, Tugby and Hallaton, and one out of both Goadby and East Norton. Amongst many legacies to relations and friends, Mrs. **Parker** left £1000 to the Rev. **George Fenwicke**, rector of Hallaton, and the Rev. **Joseph Pippin**, vicar of Tugby; instead of sharing this legacy between them, these gentlemen invested it in land in Tur Langton, which they conveyed by deed to trustees for the support of six poor aged women; three out of Hallaton, and three out of East Norton and Tugby. Mr. **Fenwicke** also gave a house close to the church at Hallaton for the three women of his parish to live in.§

(a)

The Rev. **Thomas Norris**, the donor of the paten, served as curate to Alexton and East Norton, under the Rev. **G. E. Winslow**, from 1851 to 1862, in which year he was presented to the vicarage of Tugby and East Norton which he held till 1877, when he was appointed to his present cure of souls, the rectory of Alexton.

(c)

At the death of **Mary Letitia**, Lady **Berners**, the parishioners gave a small barrel organ to this church in her memory, which was afterwards parted with when a better instrument was presented by Mrs. **Heycock**; but in order that the memory of Lady **Berners** should still be handed down by means of some utensil of the church, Mr. **Norris**, who was then curate of the parish, assisted by friends and inhabitants of the place provided the silver alms dish.

* Cathedral Register. † Vide *Old Register* of that parish, by Rev. W. D. Sweeting, Peterborough. ‡ Also M.P. for Peterborough. § Page 239.

GOSCOTE FIRST DEANERY.

ASHBY FOLVILLE.	GADDESBY.	LAUNDE ABBEY.
BARKBY.	HUMBERSTONE.	LOWESBY.
BEEBY.	ST. BARNABAS.	OWSTON.
BELGRAVE.	HUNGARTON.	PICKWELL.
ST. MICHAEL AND ALL	TWYFORD.	QUENIBOROUGH.
ANGELS.	THORPE SATCHVILLE.	THURMASTON.
BIRSTALL.	KEYHAM.	TILTON.
SOUTH CROXTON.	KNOSSINGTON.	WITHCOTE.

ASHBY FOLVILLE.

SILVER CUP. Weight 11 oz. Height $7\frac{1}{2}$ in. Diam. of the bowl $4\frac{1}{4}$ in.; of the foot $5\frac{1}{8}$ in. Height of the stem 5 in. Date 1847.

London hall marks.

This is a modern medieval cup, having a globular-shaped bowl, the stem, knob, and foot being hexagonal. Verse 13 of the 116th psalm is engraved round the bowl. Upon one division of the foot is placed a cross calvary. Underneath is "*Ashby Folville, Epiphany, 1848.*"

SILVER PATEN. Weight 3.9 oz. Diam. $6\frac{5}{8}$ in. Date 1847.

This paten is sunk in a six-lobed depression; in the centre is the sacred monogram within a circle, gilt. Round the edge is "*Lord have mercy upon us. Christ have mercy upon us.*" Underneath is "*Ashby Folville, Epiphany, 1848.*"

SILVER PLATED FLAGON. Height $7\frac{1}{4}$ in. Diam. at the top $3\frac{7}{8}$ in.; of the foot $4\frac{3}{4}$ in.

No marks.

This small tankard is made of copper, silver plated. In shape it is straight-sided, narrowing towards the top. It has a round top to the lid and the usual round handle.

PEWTER PLATE electro-plated. Diam. $9\frac{1}{4}$ in.

Marks. 1. X crowned. 2. London. 3. Between two pillars a lion rampant, "T. Bennet" below.

PEWTER PLATE electro-plated. Diam. $9\frac{1}{4}$ in.

Marks. 1. X crowned. 2. An eagle displayed rising out of a ducal crown towards the sun in splendour. 3. London. 4. In four small shapes, (a) B and V. (b) Sun in splendour. (c) Eagle's head erased. (d) Per chevron engrailed three eagles' heads erased. Both these are perfectly plain plates.

In an undated terrier at Lincoln signed by **William Parker**, rector here from 1709-1724, the church plate of Ashby Folville is as follows; "a silver cup worth about 40 shillings. A pewter flagon with King's arms, a pewter plate."

The modern cup and paten were the gift of Miss **Jane Edwards**. This lady was the second daughter of **James Edwards**, Esq., of Grove House, Harrow, by his wife **Catherine**, the eldest daughter of the Rev. **Edward Bromhead**, of Lincoln, and was born at Harrow on 19th Jan., 1813. Miss **Edwards** was connected with this parish owing to her father being the owner of an estate in Ashby Folville and Barsby, in right of his wife, whose mother was **Catherine Ayre**, daughter and heiress of **Thomas Ayre**, the owner of property here, at Kirby Bellars, and South Croxton. After the death of her father, Miss **Edwards**, lived principally with her brother the late Rev. Canon **E. J. J. G. Edwards**, vicar of Trentham, whose relative **James Edwards**, Esq., of Woodhorn manor, Morpeth, is now the owner of the family estate here. Miss **Jane Edwards** died unmarried, at Bath, on 28th Oct., 1851.

She was buried in the family vault in Harrow churchyard, at the East end of the church, over which is a large slab inscribed with the names of her father and brother, **James**, and with her own name, below which is this text; "*Who departed not from the Temple.*" There is also a painted window to the memory of this lady, at the West end of the North aisle of Trentham church, in the lower part of which are two angels holding scrolls inscribed with this text; "*Rejoicing in hope; patient in tribulation; continuing instant in prayer.*"

At the time when the modern cup and paten were presented to this church, the ancient cup was disposed of for the benefit of a district church, in which Miss **Edwards** took an interest, the name of which I have failed to learn.

The pewter flagon formerly here had been replaced by the silver-plated one before 1832.

BARKBY.

SILVER CUP WITH COVER PATEN. Weight of cup 10.9 oz. Height $7\frac{1}{2}$ in. Diam. of the bowl and of the foot 4 in. Height of stem $3\frac{3}{8}$ in. Date 1662. (PLATE 17.)

Hall marks. 1. Capital old English E in a plain shield. 2. Leopard's head crowned. 3. Lion passant; each in an outer line following the shape of the mark. 4. M, roughly formed, a mullet below, in a plain shield.

This cup has a straight-sided concave bowl with a bell-shaped lip and a flat base. The stem is conical in shape, swelling out gradually into a plain foot.

SILVER COVER PATEN with a foot. Weight 4.5 oz. Diam. $5\frac{1}{8}$ in. Diam. of foot $1\frac{3}{8}$ in. Height of foot $\frac{3}{4}$ in. Date 1662. (PLATE 17.)

Hall marks as on the cup.

This paten has a flat edge, round the inside of which is a rim. The foot is a disk with a stem swelling out at both ends; the stem being fastened to another disk $2\frac{1}{4}$ inches in diameter which is held fast to the top of the paten by four rivets.

SILVER FLAGON. Weight 36.1 oz. Height $11\frac{1}{4}$ in. Diam. of the top $3\frac{1}{2}$ in.; of the foot $6\frac{1}{4}$ in. Date 1772.

Hall marks. 1. Capital old English R in a square shield. 2. Leopard's head crowned in an oval shield. 3. Lion passant in a plain oblong. 4. C. W. in a plain oblong; probably the mark of *Charles Wright*.

This is a straight-sided flagon narrowing towards the top having a round top to its lid. In front is the sacred monogram with a cross and three nails within a circle of glory, below which is "*The Gift of William Pochin, Esqre. to Barkby Church 1773.*"

SILVER DISH with a foot. Weight 10.8 oz. Diam. $6\frac{7}{8}$ in. Diam. of the foot $2\frac{1}{2}$ in. Height of foot $1\frac{1}{2}$ in. Date 1772.

Hall marks as on the flagon.

This dish has a flat edge, the middle part being sunk flat. The foot is a disk attached to the dish by a stem swelling out at both ends. Upon the foot is engraved the sacred monogram as on the flagon, the same inscription also running round the edge of the dish underneath.

George Pochin was lord of the manor of Barkby in 1662.

William Pochin, the representative of one of the oldest families of Leicestershire, was the eldest son of **Thomas Pochin**, of Barkby, by his second wife **Mary**, the only daughter of **Thomas Trollope**,* of Bourne, co. Lincoln, and was baptized in this parish on 7th April, 1731.† He succeeded his father in the Barkby, Rearsby, Sibley and Humberstone estates in 1751, and purchased the Edmondthorpe estate from Mr. **Thomas Smith**, eleven years later for £25,000. **William Pochin** was high sheriff of Leicestershire in 1756. He was beaten, in spite of his powerful Whig supporters, in the famous contest of 1775 by **J. P. Hungerford** and the Tories; over which election such an enormous sum was spent that it was agreed he should be returned unopposed at the first opportunity. This came in 1780 when he was elected M.P. for the county and held the seat until his death, on 10th Sep., 1798.

Mr. **William Pochin** who was unmarried, and died just four months after his only surviving brother **George**, was buried near his ancestors at the East end of the North aisle of Barkby church, a slab inscribed with his name and age being placed over his grave; above, on the North wall of that aisle is a marble monument erected to his memory by his sister and heir **Mary Pochin**; upon which is an inscription, given in *Nichols* (Vol. iii., p. 63). In the same year in which he gave these two pieces of communion plate Mr. **William Pochin** re-roofed the chancel of this church and reglazed the windows; presenting also a clock in the following year. Shortly before his death he gave £100 towards augmenting the living of Thurmaston.

At the death of **William Pochin**, the **Trollope** estate at Bourne passed to his distant cousin **George Pochin**, of Loughborough, who also eventually inherited the Leicestershire estates of the **Pochins**; both are now owned by his son **William Ann Pochin**, Esq., of Barkby and Edmondthorpe.‡

* A grandson of William Trollope of Thurlby, Bourne, and Casewick, and a nephew of Sir Thomas Trollope, 1st Bart. Near the monument to the donor of this plate is one by Rysbrach, to his father, Thomas Pochin, and his two wives, at the foot of which are two shields; on the first; *Or a chevron Gules between three horse-shoes Sable*; Pochin; on an escutcheon of pretence, *Vert three stags courant Argent attired Or within a border of the second*; Trollope; on the second shield, Pochin; *impaling*; *Quarterly 1 and 4, Or, a cross Vert*, Hussey of Lincolnshire. 2 and 3 *Barry of six Ermine and Gules*, Hussey of Wiltshire: arms of his first wife Charlotte Hussey. *Nichols* is inaccurate here.

† Parish Register. ‡ For pedigree of Pochin, vide *Leicestershire Pedigrees*, by Rev. W. G. D. Fletcher, p. 36.

BEEBY.

SILVER CUP. Weight 6.6 oz. Height $6\frac{1}{4}$ in. Diam. of the bowl $3\frac{1}{2}$ in.; of the foot $3\frac{1}{4}$ in. Height of stem $2\frac{1}{2}$ in. Date 1567. (PLATE 19.)

Hall marks. 1. Small black-letter K, an annulet below, in a plain shield. 2. Leopard's head crowned. 3. Lion passant: each within an outer shaped line. 4. Duck's head erased in a stamp shaped like the head.

This pretty little cup has a deep bowl, straight-sided in the lower part swelling out higher up into a bell-shaped lip; round its middle is a band of foliage enclosed in two plain straps without curves. It has the usual evenly-balanced stem and rather flat foot, underneath which is scratched "B" for Beeby.

TWO PEWTER PATENS. Diam. of each $8\frac{3}{8}$ in.

Marks. 1. On the edge, in four small shapes: (a) W. II., a rose above. (b) A Fleur-de-lis, two pellets above. (c) Leopard's face. (d) Lion passant. 2. On the edge underneath, a windmill between W. H. within a circle.

These patens have flat edges two inches wide, the middle part being sunk flat $\frac{1}{2}$ of an inch deep.

PEWTER FLAGON. Height 8 in. Diam. at the top $4\frac{1}{4}$ in.; at the foot $4\frac{5}{8}$ in. (PLATE 17.)

Marks. 1. X crowned. 2. A unicorn's head erased, in a square stamp, repeated twice. 3. A buckle between four pellets, in a square stamp. 4. On the bottom inside; a rose between two leaves, within a circle.

This is a tankard with bulging sides and a round top to its lid.

BELGRAVE.

SILVER CUP. Weight 8.4 oz. Height $7\frac{1}{4}$ in. Diam. of the bowl $3\frac{7}{8}$ in.; of the foot $3\frac{3}{8}$ in. Height of the stem $3\frac{1}{4}$ in. Date *circa* 1680. (PLATE 22.)

The maker's mark only is to be found on this cup; this is, W. M. with a fleur-de-lis and two pellets above, and a pellet below, within a square shield.

This cup has a straight-sided bowl with a flat base, the sides swelling out slightly towards the lip. The stem and foot are conical in shape.

(a)

SILVER PATEN. Weight 2.5 oz. Diam. $6\frac{1}{4}$ in.

No marks. This paten, which is of foreign make, is plain in shape and thin, the upper part being gilt. It has a flat edge $1\frac{5}{8}$ in. wide, the middle part being very slightly sunk.

(b)

SILVER FLAGON. Weight 52.2 oz. Height $13\frac{1}{2}$ in. Diam. at the top $3\frac{3}{8}$ in.: at the foot 7 in. Date 1782.

Hall marks. 1. Small Roman G in a square shield. 2. Leopard's head crowned in an oval shield. 3. Lion passant in a plain oblong. 4. C. W. in a plain oblong. Probably the mark of *Charles Wright*. This is a large straight-sided flagon narrowing towards the top. It has a round top to its lid and the usual shaped handle. Under the foot is "*Belgrave 1782*."

PEWTER PLATE. Diam. $9\frac{1}{4}$ in.

Marks. 1. X crowned. 2. A dexter arm embowed, vambraced, rising out of a ducal crown. 3. "London." 4. B. T. S. 5. In four small shapes, (a) I. D. (b) Swan's head erased. (c) Dexter arm embowed, vambraced. (d) Per chevron engrailed three swans' heads erased.

The initials B. T. S. stand for "Belgrave, **Thomas Smith**," the name of the churchwarden from 1761 to 1763.

Nichols, Vol. iii., p. 181, quotes the terrier of 1709, in which the church plate of Belgrave is thus mentioned, "a basin, a plate, and a flaggon of pewter, a cup of silver."

(a)

The silver paten now here was presented by the Rev. **J. O. Stephens**, rector of Blankney, co. Lincoln, about thirty years ago, during the time he was curate to his father the Rev. **R. Stephens**, rector of this parish. The paten was bought at Berne, and no doubt belonged originally to some foreign church.

(b)

The silver flagon was bought by the parishioners, as is shown by the following extract from the churchwardens' accounts :

	£	s.	d.
"1782. pd for a Silver Flagon for the use of the Sacrament	22	5	6
Spent when I paid for ditto			5"

BELGRAVE. ST. MICHAEL.

(a)

SILVER CUP. Weight 8.1 oz. Height $6\frac{7}{8}$ in. Diam. of bowl 4 in.; of foot $3\frac{3}{4}$ in. Height of stem $3\frac{3}{4}$ in. Date **1878**.

Birmingham hall marks.

This cup has a V shaped bowl and plain round stem, knob and foot; on the latter is the sacred monogram within a circle of glory; and underneath; "*Belgrave 5th November, 1878.*"

SILVER PATEN. Weight 5.2 oz. Diam. 6 in. Date **1878**.

Birmingham hall marks.

This is a plain paten bearing the sacred monogram and same inscription as that on the cup.

(b)

SILVER GILT CUP. Weight 15 oz. Height $7\frac{1}{2}$ in. Diam. of bowl $4\frac{1}{4}$ in.; of foot $5\frac{5}{8}$ in. Height of stem 5 in. Date **1886**.

London hall marks.

This cup has a globular-shaped bowl and hexagonal stem, knob, and foot, ornamented with foliage. Six amethysts are set in the knob; on one lobe of the foot is the *Agnus Dei*, and on another the sacred monogram. Beneath the foot is: "*In memoriam Mariæ Hodson, obit Feb. xxiii, A.D. mdccclxxxvi.*"

(c)

SILVER GILT PATEN. Weight 3.5 oz. Diam. 6 $\frac{3}{8}$ in.

No marks.

This is a plain flat paten of modern foreign make, with small round depression in the centre. Underneath is: "*In piam Memoriam Frederici Henrici Richardson, Sacerdotis; Obiit Aug. vi., A.D. mdccclxxxvii. Requiescat in Pace. DD. Henricus F. Hinde.*"

(a)

On the 5th of Nov. 1878, a temporary church of iron erected on the Melton Road within this parish and dedicated to St. Michael and All Angels, was opened for divine worship; upon which day the silver cup and paten were presented by Mrs. **Mary Rebecca Henry**, of Elm Cottage, Belgrave, the widow of **James G. Henry**, Esq.

(b)

The iron structure has been replaced by a permanent church, built as a memorial to Mr. **Alfred Ellis**, and Canon **Henry John Burfield**, and consecrated by the Bishop on the 22nd Sep. 1887, upon which day the silver gilt cup was presented by Mr. **Edward John Holyoak**, solicitor, of Belgrave, and his family, in memory of their sister **Mary**, the wife of the Rev. **J. Hodson**, LL.D., rector of Beeby.

(c)

The silver gilt paten was bought in Milan and presented to this church by the Rev. **H. F. Hinde**, curate of Belgrave from 1880 to 1889, in memory of his late Vicar, the Rev. **F. H. Richardson**, R.D.; upon the first anniversary of whose death, 6th Aug., 1888, the paten was used for the first time.

It may well be placed on record here that as Mr. **Richardson** was the son of a much respected incumbent of this county,* so was he himself one of the most beloved and honoured parish priests within this diocese.

BIRSTALL.

SILVER CUP. Weight 9.6 oz. Height 7 $\frac{3}{4}$ in. Diam. of the bowl 4 $\frac{1}{2}$ in.; of the foot 3 $\frac{1}{2}$ in. Height of the stem 3 $\frac{1}{2}$ in. Date *circa* 1575. (PLATE 22.)

No ancient hall marks, but near the lip are stamped the Sheffield hall marks for 1832. The bowl of this cup is an inverted truncated cone, concave; having a flat projecting base, and round its middle is a band of stroke ornament divided into four parts of uneven length; the stem is evenly balanced, and the foot of the usual Elizabethan shape.

This is evidently an old cup repaired in 1832. The bottom of the bowl and the foot were apparently renewed at that time. It is larger than those stamped with the "rose" but is otherwise much the same in shape.

* See Leire.

SILVER PLATED PATEN with a foot. Diam. 6 in. Diam. of the foot 3 in. Height of the foot $2\frac{1}{2}$ in.

This paten is plain in shape with a raised moulding round its edge.

TWO PEWTER PLATES. Diam. of each $8\frac{7}{8}$ in.

Marks. 1. X crowned. 2. "London." 3. "K. R. D." each letter being crowned. 4. Eagle displayed; "Thomas" above, "Hodgkin" below. 5. On one of the plates; "W. G."

On the fly-leaf of Vol. viii. of the Birstall parish registers this entry was made by the late vicar, the Rev. **R. Stephens**, "A new Communion Cup was provided by the Parish and used on Sunday the 6th Oct., 1833, for the first time." This entry seems to forbid the supposition that the silver cup originally belonged to this parish. It belonged formerly to some church, if not to this.

The plated paten was presented by the Rev. **T. G. Gallwey**, vicar of Welford, curate here from 1873 to 1875.

The two pewter plates were the gift of the late Mr. **Richard Smith**, churchwarden of this parish about twenty years ago.

SOUTH CROXTON.

SILVER CUP. Weight 7.3 oz. Height $6\frac{3}{4}$ in. Diam. of the bowl $3\frac{1}{2}$ in.; of the foot $3\frac{3}{8}$ in. Height of stem $3\frac{1}{4}$ in. Date 1570. (PLATE 19.)

Hall marks. 1. Small black-letter N in a plain shield, in which is a mark on the top. 2. Leopard's head crowned. 3. Lion passant; each within a shaped outline. 4. A fleur-de-lis in a shaped stamp.

This cup has a bowl shaped into an inverted truncated cone; a moulding runs round it near the lip, below which is a plain strap; projecting from which, downwards, are four engraved ornaments of interlaced strap-work and foliage, two of which are larger than the other two. The stem is evenly-balanced, and the foot rounded off into a flat edge, round which is the egg and tongue ornament.

PEWTER PLATE. Diam. $8\frac{3}{4}$ in.

Marks. 1. On the edge E H. 2. Underneath: rose crowned between the date 1675, "Tho. King" above; "London" below. 3. "Made in London." 4. An anchor crowned between the date 1675; "Tho. King" above; "London" below. Some of the letters are illegible.

PEWTER PLATE. Diam. $9\frac{5}{8}$ in.

Marks. 1. On the edge S. C., for South Croxton. 2. In four small shapes: (a) A buckle. (b) Leopard's face. (c) A garb. (d) E K, two pellets above. 3. Underneath, rose crowned. 4. Illegible mark with "Ken—" above.

GADDESBY.

SILVER CUP. Weight 6.2 oz. Height $5\frac{3}{4}$ in. Diam. of the bowl 4 in.; of the foot 3 in. Height of stem $2\frac{1}{2}$ in. Date *circa* 1575. (PLATE 19.)

Mark. A rose.

This cup is of the usual shape found in this series, having a bowl shaped into an inverted truncated cone slightly concave with a flat projecting base, an evenly-balanced stem and plain foot. Round the middle of the bowl is a band of stroke ornament, divided into eight parts by hour-glass curves.

PEWTER PATEN. Diam. $9\frac{1}{8}$ in. Date *circa* 1682.

No marks.

This is a flat paten with a raised edge round which run a few mouldings. It has formerly had a foot which is not now to be found. Upon the top is "*Ex dono Dorothy Nedham 1682.*"

PEWTER FLAGON. Height 14 in. Diam. at the top $4\frac{1}{2}$ in.; at the foot $7\frac{1}{8}$ in. Date *circa* 1682.

Mark. On the bottom inside: J. C., a mullet and the date 16— above, between two sprays of foliage.

This is a straight-sided flagon narrowing a little towards the top, having a wide plain round foot. At some former time it has lost its lid, which has been replaced by a dome-shaped one made of block tin, which is surmounted by a round pewter knob taken possibly from the old lid. In front is "1682, *Ex dono Dorothy Nedham.*"

PEWTER PLATE. Diam. $9\frac{1}{8}$ in.

Marks. 1. A hare supporting a garb between two pillars, "**Samuel**" above, "**Smith**" below. 2. "Made on Snow Hill, London." 3. X crowned. 4. In four small shapes; (a) S. S. (b) Britannia. (c) Leopard's head crowned. (d) Lion's head erased.

The pewter paten and flagon were bought in accordance with this clause in the donor's will made on 18th Jan., 1680, and proved on 1st Dec., 1682, at Rothley. "*I give to the church of Gaddesby 20 shillings to buy a pewter flagon and pewter plate for the communion table.*" **Dorothy Nedham** came of a family distinguished for its benefactions of this kind to the church.* She was one of the elder daughters of **William Chamberlaine**, of Tilton, yeoman, by **Bridget**, his wife. She married **Francis Nedham**, of Gaddesby, the eldest son of **William** and **Anne Nedham**, of Belton, a member of a family originally settled at Alexton and afterwards in this parish; a younger branch of which was settled for some years at Ilston-on-the-Hill in this county.† **Francis Nedham** died in Aug., 1656, aged 63, and **Dorothy**, his widow in Oct., 1682: both were buried in Gaddesby church.

Mrs. **Nedham** bequeathed £2 to the poor of this parish to be distributed on St. Thomas' day next, after her death: £1 1s. od. to the curate: £50 each to her son **Samuel**, and daughter **Elizabeth Nedham**: legacies to her son **Francis**, and his wife: to her daughters **Mary Becket**, **Dorothy Mason**, and **Joyce Sculthorpe**, as well as to their husbands, **Francis Becket**, **Thomas Mason**, and **Edward Sculthorpe**; also to her other sons-in-law, **Arthur Cloudsley**, and **Robert Shove**. Her sisters, **Joyce Pawley**, and **Mary Chamberlaine** are mentioned. The seal on the will, which is much decayed and torn,‡ bears the arms of **Nedham**; *Argent, a bend engrailed Azure between two bucks' heads, caboshed Sable attired Or*; crest:

* See Tilton. + For pedigrees see *Nichols*, Vol. iii., p. 14, and p. 976, also Vol. iv., p. 408. ‡ Certified copies of the wills proved in the Rothley peculiar are at the Probate Office, Leicester.

A Phoenix in flames proper. The same arms and crest* are on the monuments to the **Needhams** in Ilston church, and are also carved on a stone over the door of the manor-house in that parish, now the property of the Misses **King**, and Mrs. **Corrance**, the ladies of the manor.

Francis and **Dorothy Nedham** had several children, to some of whom are monumental slabs in Gaddesby church.

HUMBERSTONE.

SILVER PLATED CUP. Height $7\frac{1}{2}$ in. Diam. of the bowl $3\frac{3}{4}$ in.; of the foot $3\frac{1}{8}$ in. Height of the stem $3\frac{1}{4}$ in.

This cup has a straight-sided bowl and a thin round stem standing upon a plain foot. Upon one side of the bowl is "*J. D. to Humberston 1834.*" About fifteen years ago this cup was gilt, the sacred monogram within a circle of glory being placed on the bowl on the opposite side to the inscription.

SILVER PLATED PATEN with a foot. Diam. 8 in. Diam. of the foot $4\frac{1}{4}$ in. Height of foot 3 in.

This is a plain shaped paten having in its centre the same inscription as that on the cup.

SILVER PLATED PLATE. Diam. $9\frac{1}{4}$ in.

This also is quite plain, having the same inscription in its centre. It has recently been gilt.

SILVER PLATED FLAGON. Height 12 in. Diam. at the top $3\frac{1}{2}$ in.; at the foot $6\frac{1}{2}$ in.

This is a tall straight-sided, hexagonal-shaped flagon. Upon its foot is "*The gift of Halford H. Adcock, M.A., Vicar, 1858.*"

In the terriers of 1712 and 1724 we are told that the church plate of Humberstone was then as follows: "A pewter flagon, pewter cup, one pewter plate, a pewter basin for the font, weighing in all $4\frac{1}{2}$ lbs."

According to Archdeacon **Bonney**, there belonged to this parish in 1832 a silver cup "given by Miss **Frewen** in 1804, through the Rev. Mr. **Dudley.**" I have been unable to discover what became of this cup. It had ceased to be in existence before Mr. **Adcock** was appointed vicar in 1856. The donor of it was Miss **Mary Frewen**,† who was the eldest daughter of the Rev. **Thomas Frewen**, and died unmarried in 1811. How she was connected with Humberstone I do not know; possibly she may have lived here after the death of her mother in 1803.

The three first silver plated pieces were the gift of the Rev. **John Dudley**, vicar of this parish, as were his father and grandfather; the three held the living in succession for forty-five, thirty-five and sixty-two years.

* Not the crest given in the Visitation of 1619, which is *On a mount Vert a stag lodged Sable attired Or.*

† See Sapcote.

John Dudley was the eldest son of the Rev. **John Dudley**, by **Bridgette**, his wife. He was one time a fellow of Clare Coll., Cambridge, from whence he took his B.A. in 1785 and M.A. in 1788. In 1794 he succeeded his father as vicar of this parish, and in the next year was appointed vicar of Sibleby; both livings were held by him till his death, on 7th Jan., 1856, in the 94th year of his age. In Humberstone church, which was re-pewed by him in 1850, is a painted window to his memory in the North side of the chancel.

The donor of the flagon, the Rev. **H. H. Halford Adcock**, succeeded Mr. **Dudley** as vicar of this parish and held the living until his resignation in 1861. During his incumbency the chancel was restored and body of the church rebuilt; the latter at the expense of his father, **Halford Adcock**, Esq.

HUMBERSTONE. ST. BARNABAS.

SILVER CUP. Weight 12.6 oz. Height $7\frac{1}{2}$ in. Diam. of bowl $3\frac{3}{8}$ in.; of foot $4\frac{3}{4}$ in. Height of stem $5\frac{3}{8}$ in. Date 1879.

London hall marks.

This cup is of medieval design with a globular bowl and a hexagonal stem, knob and foot. Round the bowl is "*Calicem salutaris accipiam et nomen Domini invocabo.*"

SILVER CUP. Weight 12.1 oz. Date 1886.

Like the first in all respects.

SILVER PATEN. Weight 5.3 oz. Diam. $7\frac{1}{2}$ in. Date 1884.

London hall marks.

This is a flat paten with a six-lobed depression; having round its edge: "*Agnes Dei qui tollis peccata mundi da nobis tuam pacem.*"

SILVER PATEN. Weight 4.9 oz. Date 1879.

Like the first in all respects.

SILVER ALMS BASIN. Weight 12.4 oz. Diam. 9 in. Depth $1\frac{1}{8}$ in. Date 1876.

London hall marks.

This dish has in its centre the sacred monogram, and round the edge: "*Hilarem datorem diligit Deus.*"

SILVER FLAGON. Weight 28.6 oz. Height 12 in. Diam. at the top $1\frac{3}{8}$ in.; at foot $5\frac{1}{8}$ in. Date 1879.

London hall marks.

This is a large jug-shaped flagon standing on a six-lobed foot. Round the middle is: "*Pascha nostrum immolatus est Christus.*" Under the foot is: "*To the Glory of God, from F. C., S. Barnabas' Church, 29th June, 1886. Rev. W. B. Mangan, M.A., Vicar.*"

This communion service was presented to St. Barnabas' church, on the day of its consecration, by **Fanny**, the wife of **John Harris Cooper**, Esq.,

which gentleman resides at Evington Hall, and is one of the principal partners of the well known firm of **N. Corah, Sons, and Cooper**, St. Margaret's works, and of **J. H. Cooper, and Co.**, Friars Causeway, Leicester. This church, the foundation stone of which was laid on 26th Nov., 1884, was built by means of a grant from the Leicester Church Extension Society, assisted by liberal subscriptions from several well wishers, of which Mr. **Cooper**, an owner of land in North Evington, was one. An ecclesiastical district has been assigned to it out of the parishes of Humberstone and Evington.

HUNGARTON.

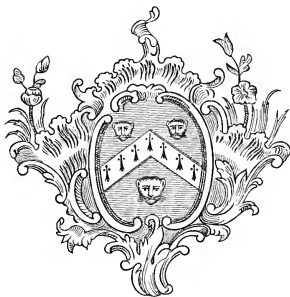

Fig. 31.

Ashby. (FIG. 31.) Below is "*Ex dono S. A. Arm. 1768.*"

SILVER PATEN with a foot. Weight 4.1 oz. Diam. $4\frac{3}{4}$ in. Diam. of the foot $1\frac{1}{2}$ in. Height of foot 1 in. Date **1768**.

Hall marks as on the cup.

This paten has a flat edge, the middle part being sunk flat. Its foot is a disk attached to the paten by a thick round stem swelling out at both ends.

SILVER PLATE. Weight 8.5 oz. Diam. $8\frac{3}{4}$ in. Date **1768**.

Hall marks as on the cup.

This is a plain plate with a raised boss in the centre, upon which is engraved the same arms and inscription as that on the cup.

SILVER FLAGON. Weight 42.6 oz. Height 11 in. Diam. at the top 4 in.; at the foot $7\frac{1}{4}$ in. Date **1768**.

Hall marks as on the cup.

This is a straight-sided flagon narrowing towards the top, with a wide sloping foot and a round top to its lid. In front is the same coat of arms and inscription as that on the cup.

SILVER CUP. Weight 9.1 oz. Height $7\frac{3}{4}$ in. Diam. of the bowl $3\frac{1}{2}$ in.; of the foot $3\frac{1}{2}$ in. Height of stem 4 in. Date **1768**.

Hall marks. 1. Capital old English N in a square shield. 2. Leopard's head crowned in an oval shield. 3. Lion passant in a plain oblong. 4. I. K., a pellet between the letters, in a plain oblong.

This cup has a straight-sided bowl rounded off below with a raised lip, and a straight and narrow stem having below its middle a small moulding for a knob; the foot has some mouldings running round its edge. Upon the bowl is this coat of arms; *Azure, a chevron Ermine between three leopards' faces, Or.*

PEWTER PLATE. Diam. $8\frac{3}{4}$ in.

Marks. 1. X crowned. 2. Rising out of a ducal crown, a horse's jamb, within an ornamental shape. 3. "London" in an oblong. 4. In four small shaped shields; (a) S. D. (b) Talbot's head erased. (c) Horse's jamb. (d) Per chevron engrailed three talbots' heads erased.

The terrier of 1709 tells us that there then belonged to this church; "A silver cup and cover weighing $8\frac{1}{2}$ oz.: a pewter flagon: a pewter plate." None of these pieces are mentioned in Archdeacon **Bickam's** inventory of 1777.

The donor of the service now here was **Shukbrugh Ashby**, F.R.S., the eldest son of **Shukbrugh Ashby**, of Blaby, by **Mary**, daughter and heir of **Nathaniel Cradock**, of Cossington, and was born on 6th Oct., 1724. This gentleman, who through a younger branch, was descended from the two old families of **Ashby**, of Quenby, and **Ashby**, of Lowesby, was high sheriff for Leicestershire in 1758, and member for the borough of Leicester in 1784. In 1759 he bought the Quenby Hall estates from his father's first cousin, Mr. **Waring Ashby**, who had succeeded to the ancient family property owing to his elder brother, **John**, having been disinherited by their father, **George Ashby**. Mr. **Shukbrugh Ashby**, after he had purchased Quenby from his relative, and sold his property at Blaby, nearly rebuilt the adjoining village of Hungarton. He died on 27th Jan., 1792, and was buried in Hungarton church.

Where, upon the East wall of the South aisle, is a marble monument to his memory; the inscription on which tells that "he was a man eminently distinguished for his learning, probity, and benevolence:" at the top of the monument are; the arms of **Ashby** bearing on an escutcheon of pretence, *Argent, three stags trippant Gules*, **Hinde**; crest: out of a mural crown, *Argent a lion's face affronté Or*. Motto: "*Be just and fear not.*"

Mr. **Shukbrugh Ashby**, married **Elizabeth**, daughter and heir of **Richard Hinde**, of Cold Ashby, Northants, who died on 8th Nov., 1795, aged 72: by whom he had two daughters, his co-heirs; the eldest, **Mary Elizabeth**, married **William Latham**, Esq., of Eltham, Kent, and after her husband's death took the name of **Ashby**. In default of male heirs that lady's great grand-daughter, **Annie Ashby**, who died 30th June, 1886, took the Quenby estates to her husband, Mr. **Nicholas Herman Bernard**, who changed his name to **Ashby**.*

TWYFORD.

SILVER CUP AND COVER PATEN. Weight of cup 4.1 oz. Height $5\frac{1}{4}$ in. Diam. of the bowl 3 in.; of the foot $2\frac{3}{4}$ in. Height of the stem $2\frac{1}{2}$ in. Date 1569. (FIG. 32.)

* For pedigree of **Ashby**, see *Leicestershire Pedigrees*, by Rev. W. G. D. Fletcher, F.S.A., p. 111.

Hall marks. 1. Small black-letter M in a pointed shield. 2. Lion passant. 3. Leopard's head crowned, each of the two last having an outside line following its outline. 4. I. P., within a shaped shield.

This little cup is a good example in miniature of the usual Elizabethan piece. Each of the bands of foliage round its bowl is divided into four parts by hour-glass curves.

SILVER COVER PATEN with a foot. Weight 1.4 oz. Diam. $3\frac{1}{4}$ in. Diam. of the foot $1\frac{1}{2}$ in. Height of foot $\frac{3}{4}$ in. Date 1569. (FIG. 32.)

Hall marks as on the cup.

This paten is of the usual shape in every respect.



Fig. 32. 1569. Rather more than $\frac{3}{4}$ of full size. M. P. del.

SILVER CUP. Weight 9.2 oz. Height 7 in. Diam. of bowl $3\frac{1}{2}$ in.; of foot $4\frac{1}{4}$ in. Height of stem 5 in. Date 1850.

London hall marks.

This cup has a globular-shaped bowl, inscribed with the text; "*I will take the cup of salvation and call upon the name of the Lord.*" The stem, knob, and foot are hexagonal, the latter being shaped into six lobes.

SILVER PATEN. Weight 4 oz. Diam. $6\frac{1}{2}$ in. Date 1850.

This paten has a flat edge, the middle part being sunk in a six-lobed depression. Round the edge is "*O Lamb of God, that takest away the sins of the world, grant us Thy peace.*"

SILVER DISH. Weight 8.4 oz. Diam. $7\frac{7}{8}$ in. Date 1850.

This dish is the same in shape as the paten. Round its edge is: "*He that hath pity upon the poor lendeth unto the Lord.*"

PEWTER FLAGON. Height $14\frac{1}{4}$ in. Diam. at the top $4\frac{3}{8}$ in.; at the foot $8\frac{1}{8}$ in.

Mark under foot: "James Dixon and Sons."

This very large flagon is straight-sided in shape.

The three modern pieces were presented to this church during the incumbency of the late Rev. George Knight, vicar of this parish from 1843 to 1882.

THORPE SATCHVILLE.

SILVER CUP. Weight 13.3 oz. Height $8\frac{1}{2}$ in. Diam. of the bowl $3\frac{1}{4}$ in.; of the foot $3\frac{5}{8}$ in. Height of the stem 5 in. Date 1752.

Hall marks. 1. Small Roman R. 2. Leopard's head crowned; both being within a shaped shield. 3. Lion passant in a plain oblong. 4. P. G., a pellet between the letters and a guttée above, within a shaped stamp. The mark of *Phillips Garden*.

This is a peculiar shaped cup, being nearly all stem. It has a small bowl in the shape of an inverted truncated cone, and a thick long round stem, having a round knob below the middle. The foot is a round plain one. On the bowl is the sacred monogram, with the cross above and three nails below, within a circle of glory. Below the monogram is: "*Thorpe Satchvile Chapell.*" Underneath the foot is: "*The gift of Geo. Williamson, 1752.*"

SILVER PATEN with a foot. Weight 6.2 oz. Diam. $4\frac{3}{4}$ in. Diam. of the foot $1\frac{3}{4}$ in. Height of foot $\frac{7}{8}$ in. Date 1752.

Hall marks as on the cup.

This paten has a flat edge, from whence the middle part is slightly sunk. On the foot is the sacred monogram, with the cross and three nails, within a circle of glory, and beneath the paten is: "*Thorpe Satchvile Chapell, the gift of Geo. Williamson, 1752.*"

SILVER FLAGON. Weight 42.3 oz. Height $10\frac{5}{8}$ in. Diam. of the top $3\frac{7}{8}$ in.; of the foot $6\frac{1}{4}$ in. Date 1752.

Hall marks as on the cup.

This is a straight-sided flagon, narrowing towards the top. In front is the sacred monogram, with the cross and nails, within a circle of glory, below which is: "*Thorpe Satchvile Chapell.*" Underneath the foot is: "*The gift of Geo. Williamson, 1752,*" and the weight 42 oz. 9 dwts.

SILVER DISH. Weight 17.1 oz. Diam. $9\frac{1}{2}$ in. Depth 1 in. Date 1733.

Hall marks. 1. Capital Roman S in a pointed shield. 2. Leopard's head crowned in a pointed shield. 3. Lion passant, in a plain oblong. 4. P. C., very illegible.

This dish is pentagonal in shape, with a gadrooned edge. Underneath is the same inscription as that on the paten, and the weight 17 oz. 3 dwts.

SILVER DISH. Weight 15.5 oz. Diam. $9\frac{1}{2}$ in. Depth 1 in. Date 1746.

Hall marks. 1. Small Roman L in a shaped shield. 2. Lion passant in a plain oblong. 3. Leopard's head crowned in a shaped shield. 4. P. L. in script letters, a pellet below and a crown above, within a shaped stamp. The mark of *Paul Lamerie*.

This dish is the same in shape as the last; both have evidently been dinner plates originally. Beneath this one is the same inscription as that on the paten, and also the weight 15 oz. 11 dwts.

No older plate than this is mentioned in Archdeacon **Bickam's** inventory of 1777.

George Williamson came of a yeoman family owning land for many years in this parish; his ancestor and namesake was a freeholder here in 1630. He was the son of **George** and **Mary Williamson**, and was baptized at Twyford on 6th Feb., 1690.* In early life he settled at Stamford, co. Lincoln, being apprenticed in 1704 to **Robert Collington**, grocer; he afterwards started business in that trade on his own account, and accumulated a handsome fortune by his industry.† He was appointed Mayor of that town in 1735, a few months after he had been elected Alderman.

There are many proofs of this gentleman's charitable disposition. To his parish church, St. Michael's, Stamford, he gave 50 guineas in 1761 towards rebuilding its tower, afterwards taken down with the ruins of the body of the church, which dated from the 12th century, in 1834. The town of his adoption has, however, a witness to his bounty which has fared better than that gift, in the hospital for widows founded by him. This consists of a very unpretentious but comfortable, low old-fashioned house in St. Peter's Hill, which he set apart for an almshouse during his life, as is recorded by this inscription on a small slate slab over the door leading into the yard: "*Widows Houses Given 1762 By George Williamson.*" In the front part four widows are housed, two on the ground floor and two above, having one room apiece; in that part at the back which runs out at right angles from the front are housed three widows, who have two rooms each, one below and above.

In addition to presenting this service of communion plate, Mr. **Williamson** further showed his affection for his native place by giving in 1764, by deed, an annual rent charge of £1 for the benefit of the poor of Thorpe Satchville, arising out of a field called Oxen close in this parish; at the same time he made the same gift to the poor of Twyford.

Mr. Alderman **Williamson** died without issue on the 28th of Jan., 1769, and was buried in old St. Michael's church, Stamford, in a vault under the tower, on Feb. 1st. His wife **Sarah** died on the 6th Sep., 1775, aged 81, and was buried by the side of her husband on Sep. 9th.

A plain marble tablet bearing a short inscription was put up in that church to their memory, and was preserved when the church was rebuilt by being placed under the gallery at the West end of the present building; this memorial, however, to one of Stamford's benefactors, is now no longer in existence.

By his will made on 9th Dec., 1768, and proved, with a codicil dated 25th Jan., 1769, P.C.C. on 10th March, 1769, **George Williamson** left to his wife £1000, his shop in Stamford bought from **Catherine Walburge**, and other properties close to. Legacies of various amounts to these relations: his sister-in-law **Elizabeth Nixon**, brother-in-law **Robert Mael**, nephews **George Williamson**, **Thomas Williamson**, **Joseph Williamson**, and great-nephew **William Whinfield**; nieces **Ann Parkinson** and **Mary Gates**; legacies also to

* Parish Register. † See *Chronology of Stamford*, by G. Burton, p. 285, and *Charities* p. 38; and *Lincolnshire Tradesmen's Tokens*, p. 97, by Justin Simpson.

Sarah, wife of Roberts, grocer, of Bourne, Thomas Robert Gates, gent., of Spalding, Thomas Nixon, of Lombard Street; he left also £3000 in trust, ordering the interest therefrom to be paid to his wife for life, and the capital sum after her death to be divided in certain portions amongst various nephews and nieces. His almshouse he bequeathed to his wife in these words: "*I give and devise to the said Sarah Williamson all that messuage or tenement now divided into several tenements, occupied by six poor widows, situate and being on St. Peter's Hill, in Stamford aforesaid, with the appurtenances, late the estate of Mr. Theophilus Buckworth.*" This building his wife made over permanently to trustees in Aug., 1770, presenting to them also certain houses in Red Lion Square, the rents from which she devoted to the repair and insurance of the almshouse, and the payment of taxes thereon, and to the purchase of coal in summer to be sold to the poor of Stamford in winter; which latter clause of the trust has long ceased to be carried out, having been found of no benefit, the price of coal being almost as high in summer as winter. The widows in the almshouse have now the advantage of a weekly sum of money, derived from the rent of the property in Red Lion Square, and also from two additional endowments both invested in the funds, one being the bequest of Mr. John Warrington in 1806, the other of Mr. Henry Fryer in 1822.

 KEYHAM.

SILVER CUP AND COVER PATEN. Weight of cup 7 oz. Height 6½ in. Diam. of the bowl 3½ in.; of the foot 3¾ in. Height of stem 2½ in. Date 1634. (PLATE 23.)

Hall marks. 1. Italic R in a plain shield. 2. Leopard's head crowned. 3. Lion passant: each within an outer shaped line. 4. R. M., a cinquefoil below, within a shaped stamp.

This cup has a bowl shaped into an inverted truncated cone, with a lip slightly bell-shaped, and a plain stem without a knob, swelling into a moulded foot. The lion passant is repeated under the foot.

SILVER COVER PATEN with a foot. Weight 2.5 oz. Diam. 4¾ in. Diam. of the foot, 1¾ in. Height of foot ⅞ in. Date 1634. (PLATE 23.)

Hall marks as on the cup.

This paten has a flat edge from which the middle part is sunk flat; in the centre is a further flat depression. The foot is a disk attached to the paten by a narrow stem swelling out at both ends. Upon the foot is 1634; "E. W." above the date, "T. R." below.

SILVER CUP. Weight 7.3 oz. Height 6⅞ in. Diam. of the bowl 3½ in.; of the foot 3⅞ in. Height of stem 4½ in. Date 1872.

London hall marks.

This cup has a bowl shaped into an inverted truncated cone, a round stem with a large round knob and a plain round foot.

SILVER PATEN. Weight 3 oz. Diam. 4¾ in. Date 1872.

This paten which fits on to the cup is quite plain in design.

SILVER FLAGON. Weight 13.6 oz. Height 10¾ in. Diam. at the top 1⅝ in.; at the foot 3½ in. Date 1872.

This is a plain jug-shaped flagon with a conical-shaped lid surmounted by a cross.

SILVER CUP. Weight 2.6 oz. Height $3\frac{3}{8}$ in. Diam. of the bowl and foot $2\frac{1}{4}$ in. Height of stem $2\frac{1}{4}$ in. Date 1871.

London hall marks.

This little cup has a globular-shaped bowl, a round stem and knob and hexagonal foot, on which is engraved the sacred monogram.

SILVER PATEN. Weight 1 oz. Diam. $3\frac{1}{4}$ in. Date 1871.

This is a plain paten with the sacred monogram engraved on the back within an ornamental circle.

GLASS CRUET WITH SILVER STOPPER. Height $4\frac{1}{4}$ in. Date 1871.

The first mentioned modern service was presented to this church by Miss **Esther Clementina Miles**, of St. Leonards, the youngest daughter of the late **Roger Dutton Miles**, Esq., of Keyham house.

The second modern service, which fits into a case and is used for administering the holy communion to the sick, was the gift of **Justina**, the wife of Mr. **Williams**, of the Admiralty, and the eldest surviving daughter of the late **R. D. Miles**, Esq.

KNOSSINGTON.

SILVER CUP AND COVER PATEN. Weight of cup 9.5 oz. Height $7\frac{1}{2}$ in. Diam. of bowl $4\frac{1}{2}$ in.; of foot $4\frac{1}{4}$ in. Height of stem $3\frac{3}{4}$ in. Date *circa* 1660.

One mark only. T. I., a star of six or seven points below, in a plain shield.

The bowl of this cup is nearly straight-sided, widening out only a little, it has a flat base. The stem above the middle, has a small moulding for a knob, from which it swells straight out towards the bowl, and straight out into a conical-shaped foot. The foot is rounded off into a flat edge.

SILVER COVER PATEN with a foot. Weight 4.4 oz. Diam. $5\frac{1}{4}$ in. Diam. of foot $2\frac{3}{4}$ in. Height of foot $\frac{5}{8}$ in. Date *circa* 1660.

Same maker's mark as on cup.

This paten has a flat edge $\frac{1}{4}$ inch wide, the middle part being sunk flat $\frac{1}{4}$ inch in depth. The foot is a disk attached to the paten by a conical stem swelling out towards the foot.

SILVER CUP. Weight 7.7 oz. Height 7 in. Diam. of bowl $3\frac{1}{8}$ in.; of foot $3\frac{7}{8}$ in. Height of stem $4\frac{1}{4}$ in. Date 1867.

London hall marks.

This cup has a small egg-shaped bowl, baluster stem, and plain foot, underneath which is: "*Presented to the Rev. Duke Harington, M.A., Rector, for the use of the parish church at Knossington, by S. Duncan, of the Grange. A.D., 1868.*"

SILVER PATEN. Weight 6.3 oz. Diam. 7 in. Date 1867.

This is a plain paten with a flat edge. Underneath is the same inscription as that on the last cup.

SILVER FLAGON. Weight 15.9 oz. Height 9½ in. Diam. at the top 2½ in.; at the foot 3¾ in. Date 1867.

This is a straight-sided flagon narrowing to the top.

SILVER CUP. Weight 10 oz. Height 7¼ in. Diam. of bowl 3¼ in.; of foot 5 in. Height of stem 4⅝ in. Date 1882.

London hall marks.

This cup has a globular-shaped bowl, hexagonal stem and knob, and a foot shaped into six lobes. Upon each of the six faces of the knob is a carbuncle set in gold. Upon one of the divisions of the foot is the sacred monogram. Underneath the foot is: "*From A. G. W., and A. G. T., in memoriam A. G. H. S., Easter 1882.*"

SILVER PATEN. Weight 4.5 oz. Diam. 6 in. Date 1882.

This is a flat paten having in its centre within an ornamental circle the sacred monogram gilt. Upon the edge are four crosses *bottonnée*, each in a circle.

SILVER SPOON. Weight 5 oz. Length 5 in. Date 1879.

This spoon has a spiral stem and a cross within its handle.

PEWTER PLATE. Diam. 8⅝ in.

Marks. 1. X crowned. 2. "Made in London." 3. Rose crowned, "London" above, perhaps illegible name below. 4. These arms, quarterly: 1 and 4 blank. 2 and 3 a fret; over all a bend; above the arms, T. S., and a spray of foliage on either side, the whole within an oval.

The three first mentioned pieces of modern communion plate were given to this church by **Sarah Duncan**, *née* Miss **Butler**, of Boston, U.S., the wife of **Alexander Duncan**, Esq., of Providence, Rhode Island, the Grange, Knossington, and 7, Prince's Gate, London. This gift was made to this church a few months after Mr. and Mrs. **Duncan** had bought and enlarged Knossington Grange. The church has since been restored by them at a cost of £2500.

The later modern pieces of plate were the gift of **Adele Grainger Winthrop**, and her daughter, **Adele Grainger Thayer**, in memory of their friend, **Adele Hamilton Stubber**, who was the god-daughter of Mrs. **Winthrop**, and with whom they partook of the Holy Communion together for the last time within this church upon Easter day 1882.

LAUNDE ABBEY.

At Launde Abbey, the seat of **E. F. Dawson**, Esq., is a private chapel formed out of a portion of the church of the Priory of Austin Canons, once here.* For the celebration of the Holy Communion in this chapel Mr. **Dawson's** father† bought from Messrs. **Lambert**, about fifty years ago, two ancient cups.

* The Prior successfully smuggled away some of the valuables of his house shortly before its suppression. Vide *Hen. viii. and the English Monasteries*, Vol. ii., p. 283. F. A. Gasquet. † Vide p. 43.

One of these is a SILVER GILT CUP. Weight 9.2 oz. Height $6\frac{1}{2}$ in. Diam. of bowl $3\frac{3}{4}$ in.; of foot $4\frac{1}{8}$ in. Height of stem 4 in. Date *circa* 1450. (FIG. 33.)

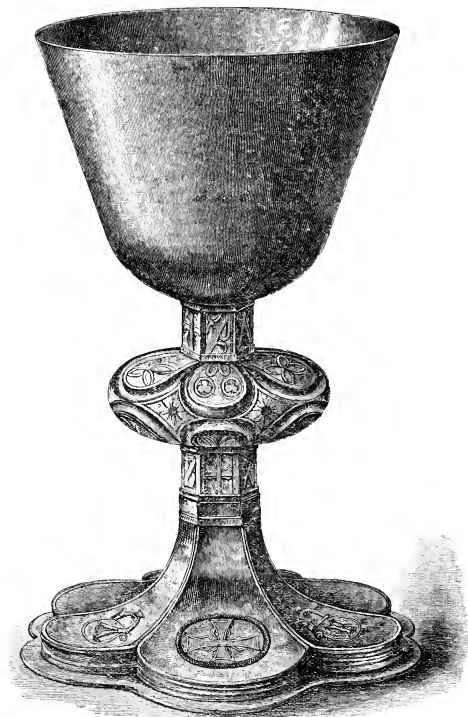

Fig. 33. Circa 1450. Nearly full size. M. P. del.

hook; the one on the left bears a hemp-break or bray, the other a tree eradicated bearing two large leaves. I have been unable to attach these symbols to any saint in particular, and am inclined to think that the scrips may represent the pilgrimage of life with its trials and reward; the bray pointing to the crushing out of evil within by the pains of self-denial, and to all suffering endured for Christ's sake; the tree representing the Tree of Life, its two leaves showing forth

No marks.

This cup, probably of German make, has a conical bowl, hexagonal stem, large round knob and foot, shaped into six lobes.

The latter perhaps once formed the foot of another cup having a slightly narrower stem than this one; for the usual moulding at the junction of stem and foot is wanting, and at that point some repair has once been rather clumsily made, for a rivet has been inserted through the stem. All the ornament is engraved. The knob is divided by deep grooves into six lobes above and below, each lobe bearing tracery; the four-leaved flower being in between. On each side of the stem is a panel of tracery, with the exception of one which bears a chasuble and pall. On the foot is a cross patée, cusped, within a circle covered with a zigzag line. On the lobes to right and left is a scrip with its strap hanging on a

the divine and human nature of the Saviour. The whole cup is rather bent and has a more worn appearance than can be shown in an illustration.

The other ancient Cup is also silver gilt. Height 11¼ in. Diam. of bowl 4¼ in.; of foot 7⅞ in. Height of stem 7¼ in. Date *circa* 1700.

No marks.

This is a German made cup, much the same in style as the one at Gopsal. It has a small straight-sided bowl, a baluster stem and a large raised foot. The cup is covered with elaborate ornament repoussée. Upon the bowl are three cherubs' heads; between which are three oval enamels bearing these subjects: 1. The trial of the Saviour. 2. The scourging. 3. The crowning with thorns. Three angels' heads are placed upon the knob of the stem. Upon the foot are three cherubs bearing the symbols of our Lord's passion; between which are three more oval enamels containing these subjects: 1. Our Lord's agony in the garden of Gethsemane. 2. Christ bearing the cross. 3. The crucifixion; foliage forming the ground-work in between.

A modern silver gilt paten and dish complete the communion service used in this private chapel.

LOWESBY.

SILVER CUP. Weight 8.2 oz. Height 6½ in. Diam. of bowl and of foot 3½ in. Height of stem 2⅞ in. Date 1614.

Hall marks. 1. Lombardic R in a plain shield. 2. Leopard's head crowned. 3. Lion passant; each within an outer line. 4. W. R., over two curved lines, within a plain shield.

This cup has a bowl shaped into an inverted truncated cone slightly concave, with a flat base. The stem is evenly balanced, divided in half by a large round moulding between two small hollows for a knob, swelling out towards both ends into plain vertical edges. The foot is a high one, having on the top a large round moulding, ending in a flat edge with a small moulding running round it. On the bowl is: "*The communion cup of Lowesby;*" below which is this crest: *a garb Or, supported by two lions, the dexter Argent, the sinister Azure, a mullet for a difference, Cecil.* Underneath is "1614." (FIG. 34.) Under the foot is the weight, 10 oz. 3 qtrs.



Fig. 34.

SILVER PATEN with a foot. Weight 2.4 oz. Diam. 3⅞ in. Diam. of foot 1½ in. Height of foot ⅝ in. Date 1614.

Hall marks as on cup.

This paten has a flat edge ½ in. wide, with a few lines running round it, the middle part being sunk flat ¼ in. in depth. The foot is a disk attached to the paten by a round stem swelling out at both ends. In the centre of the paten is a cross patée. This is an early example of a plain paten and not a cover, fitting on the cup with the foot downwards.

GLASS FLAGON WITH SILVER PLATED TOP. Height 9 in.

PEWTER PLATE. Diam. 9½ in.

Marks. In the centre "F. G. F.," for Frederick Gustavus Fowke. On the back. 1. X crowned. 2. "London." 3. Eagle rising out of a ducal crown towards sun in splendour.

4. In four small shapes; (a) B and V. (b) Sun in splendour. (c) Eagle's head erased. (d) Per chevron engrailed, three eagles' heads erased.

The cup and paten mark the connection which existed for a few years between this parish and the family of **Cecil**. By deed dated 14th Oct., 1599, **Thomas Cecil**, 2nd Lord **Burghley**, afterwards 1st Earl of **Exeter**, bought the estate of **Lowesby** from **Richard Paramour**, and afterwards apparently settled it in part upon his fifth son, **Thomas Cecil**, afterwards knighted, who in 1605 married **Anne**, daughter of Sir **Robert Lee**, Knt., and alderman of London. Here **Thomas Cecil** and his wife seemed to have lived until 1615, when by deed dated the 10th of Nov., they both, together with Lord **Exeter**, conveyed the estate to **George Ashby**, of **Quenby**, and his son and heir **George**, for £12,040.*

The mullet on the **Cecil** crest shows this gift of communion plate to have been made by **Edward Cecil**, third son of the 1st Earl of **Exeter**, by his first wife, **Dorothy**, daughter and co-heir of **John Neville**, Lord **Latimer**. This distinguished "soldier of fortune" was born at **Burghley House**, on 29th Feb., 1571-2. When a young man he joined the English troops under Sir **Francis Vere**, in the service of the Low Countries against the King of **Spain**, and soon proved himself a brave and determined soldier both at **Nieuport** and **Ostend**, for which services he was knighted by Queen **Elizabeth**, at **Basing**, on 14th Sept., 1601. In the first parliament of King **James**, which met 19th March, 1603-4, he represented his native town of **Stamford**; he had before been returned for **Aldborough**, and afterwards sat for **Chichester** and **Dover**. Having served under the States in various campaigns, Sir **Edward Cecil** was in 1610 appointed to the command of the four-thousand troops sent by King **James** to assist the States in their war on behalf of the Elector of **Brandenburg**, and the Court of **Neuburg**, who claimed the Duchies of **Juliers** and **Cleves**, seized by the Emperor; he took a leading part in the siege of **Juliers**, the surrender of which was effected principally through his diligence and judgment. Continuing in the service of the States, he had an important share in various expeditions made on behalf of the Elector Palatine, until the accession of King **Charles I.**, when the ill-fated attempt on **Cadiz** being determined upon, the command was given to Sir **Edward Cecil**. Upon his return Sir **Edward**, who had before this been made a privy councillor, took out his patent for the title of Viscount **Wimbledon**, conferred upon him the year before, and took his seat in the House of Lords on 4th May, 1626: on 18th Dec., he and the Earl of **Nottingham** were made Lord Lieutenants

* During the Commonwealth, **Lowesby** was bought by **Richard Woollaston**, gun-founder to **Oliver Cromwell**, through whose family it is the inheritance of its much respected owner, Sir **F. T. Fowke, Bart.**, in whose possession are the deeds above mentioned.

of Surrey, in the next year he returned to his old masters in the Low Countries, and held his command under the States till 1631, when he finally retired from their service and came to England to end his days at home. In his last years Lord **Wimbleton** was much occupied with his command at Portsmouth, to the governorship of which he had been appointed on 31st July, 1630. He died at his house at Wimbleton, co. Surrey, which had been left him by his father, on 16th Nov., 1638, and was buried in a side chapel on the South of the chancel in the parish church of that place where there is an altar-tomb of black marble to his memory.

Lord **Wimbleton** married three times: first on 10th June, 1601, at Brook, co. Rutland, **Theodosia**, daughter of Sir **Andrew Noel**, Knt., of Brook and Dalby-on-the-Wolds, co. Leicester, by **Mabel**, daughter of Sir **James Harrington**, Knt., of Exton, co. Rutland; which lady died at Utrecht, in March, 1616, secondly, on 27th Feb., 1617-18, **Diana**, daughter of Sir **William Drury**, Knt., of Hawsted, Suffolk, by **Elizabeth**, daughter of Sir **William Stafford**, Knt., and co-heir of her brother, Sir **Robert Drury**, Knt.; she dying in May, 1631, Lord **Wimbleton** married in Sept., 1635, a bride 46 years younger than himself, **Sophia**, eldest daughter of Sir **Edward Zouch**, Knt., of Woking, Surrey, by **Dorothea Silking**, his wife. Lady **Wimbleton** after her lord's death married a widower, Sir **Robert King**, Knt., of Boyl, Connaught: she died on 12th Nov., 1691, and was buried in Ketton church, co. Suffolk, where there is a monument to her memory. Viscount **Wimbleton*** left surviving issue by his first wife only, viz. four daughters; 1. **Dorothy** died unmarried. 2. **Albinia** married to Sir **Christopher Wray**, Knt. 3. **Eliza** married to 5th Lord **Willoughby**, of Parham. 4. **Frances** married to **James**, Lord **Saye and Sele**.

In his will dated 1st Nov., 1635, and re-written in 1637, and proved P.C.C. 21st Dec., 1638, he desired to be buried by the tomb of his second wife in the chapel built for that purpose in Wimbleton church. He left to his wife for life the parsonage, lordship and tithes of Wimbleton, with all goods and chattels. To his sister, the Countess of **Norwich**, "my chaine of gold with the cross of diamonds that I did ordinarily wear which was my dearest mother's, and was called a Lattimer's cross,† not as a recompense but as a thankfulness for her liberality that she did bestow of me in my want, and especially at my coming out of Fleely,‡ more than any of my friends besides:" to her also a watch with his grandfather's picture cut upon it out of agate. Legacies to chaplain and servants: charity to Wimbleton for keeping the tomb and chapel in repair, and apprenticing poor children: all other lands, goods, leases, to his heirs male, for want of such to his daughters and their heirs. Executors, Sir **Chris. Wray**: Sir **Tho. Grimes**, Knt.: Sir **Will. Elliott**, Knt.: Cousin **Robt. Dewhurst**: Capt. **Tho. Brett**.

The arms of **Cecil** are: *Barry of ten, Argent and Azure, over all six escutcheons, 3, 2, and 1, Sable, each charged with a lion rampant of the first.*

It was probably when staying with his younger brother at **Lowesby**, that Lord **Wimbleton** made this gift of communion plate: he is known to have been in England in 1614.

* For full particulars of this valiant soldier see his *Life and Times*, by C. Dalton, F.R.G.S., 2 Vols. and for pedigree, *Blore's Rutland*, p. 82. † Arms of Latimer, "Gules a cross patonce Or." ‡ Sic: Original name erased, thought by Mr. Dalton to have been "Italy."

OWSTON.

SILVER CUP WITH A COVER PATEN. Weight 10.5 oz. Height $8\frac{1}{8}$ in. Diam. of bowl $3\frac{3}{4}$ in.; of foot 4 in. Height of stem $3\frac{3}{4}$ in. Date 1816.

London hall marks.

This cup has a straight-sided bowl rounded off below, with a raised lip; a straight round stem, with a small moulding for a knob, and a plain round foot. Upon the bowl is the sacred monogram, with a cross and three nails, within a circle of glory.

SILVER COVER PATEN with a foot. Weight 3.2 oz. Diam. $4\frac{5}{8}$ in. Diam. of foot $1\frac{1}{4}$ in. Height of foot $\frac{5}{8}$ in. Date 1846.

London hall marks.

This cover has a flat raised edge, so constructed as to allow the paten to fit on to the cup both ways. In the centre is the sacred monogram as on the cup.

SILVER DISH. Weight 7.9 oz. Diam. $7\frac{1}{8}$ in. Date 1846.

London hall marks.

This is a plain dish, having in its centre the sacred monogram as on the cup. On the back is: "*The Parish of Owston in the county of Leicester. Anno Domini 1846.*"

SILVER FLAGON. Weight 15.9 oz. Height $10\frac{1}{2}$ in. Diam. at the top $1\frac{3}{4}$ in.; at the foot $3\frac{1}{4}$ in. Date 1877.

London hall marks.

This is a good jug-shaped flagon. Its lid is surmounted with a cross *bottonnée*, the handle terminating at both ends in a trefoil.

From an entry made in the register of this parish in 1846 by the Rev. **Charles Heycock**, incumbent from 1827 to 1855, we learn that the "communion service for ages consisted of mere Pewter vessels" until the time of the Rev. **Joseph Cragg**, curate from 1785 to 1808, and incumbent from then to 1827, when the silver cup "was obtained by his importunities and pecuniary assistance, with the help of the churchwardens of the parish." The silver cover paten and dish were presented in 1846 by **Edward Conder**, Esq., of London. This gentleman was the representative of an old statesman family of Westmoreland, being the direct descendant of **Richard Conder**, of Old Town, Mansergh, who died in 1590, and whose son **Edward** bought in 1608 the property of Terry Bank in that township, which has ever since been in the possession of this family. The donor of these two pieces was the eldest son of **Edward Conder**, of Terry Bank, by his wife **Elizabeth**, daughter of **James Cragg**, of Dent, co. York, and was baptized at Kirkby Lonsdale on 11th Dec., 1790. He was educated first at Kirkby Lonsdale Grammar School, then with his uncle, the rector of Wymondham. From early life Mr. **Conder** was a man of business; in 1818 he settled in London, and eventually became the principal partner in the firm of **Evans, Conder, and Thorn**, coffee merchants, of Queen Street, Cheapside, now of Upper Thames Street. Mr. **Conder** took a leading part in the affairs of the Corporation of the city of

London, and was elected alderman for the Ward of Bassishaw in 1859, and was in the same year sheriff of London and Middlesex. He was also a freeman and past master of the Company of Wheelwrights. It was through his mother's family that his connection with the parish of Owston arose, the rector, the Rev. **Joseph Cragg**, being his uncle, while his other uncle, the Rev. **Richard Cragg**, rector of Wymondham, made him a present of his property situated here, in the hamlet of Newbold Saucey. Mr. Alderman Conder, who was also the owner of property in Westmoreland and in Dent, co. York, died at Havering-atte-Bower, co. Essex, on 12th Jan., 1865, and was buried in Tower Hamlets cemetery. He married on 20th June, 1820, at St. Botolph's, Aldgate, **Elizabeth Vaux**,* which lady died leaving no issue, and was buried in Tower Hamlets cemetery.

On the South wall of Owston church is a brass tablet, bearing a short inscription to the memory of the Rev. **J. Cragg**, and his nephew, Mr. Alderman **Conder**. There is also a painted window to the memory of the latter in Mansergh church, beneath which is an inscription recording the fact.

Mr. **Conder** bore these arms: *Argent on a bend wavy Azure between two lymphads Sable an anchor entwined with a cable Or.* Crest: *In front of a lymphad Sable an anchor, its fluke to dexter Or.* Motto: *Je conduis.*

This gentleman dying without issue, was succeeded in his Newbold Saucey and other estates by the eldest son of his next brother **Richard, Edward Conder**, Esq., of Elm Hurst, Romford, co. Essex, who also inherited the Terry Bank estate from his uncle **Joseph Conder**, who died without issue in 1868.

The silver flagon was the gift of the Rev. **Frederick Dickinson Hall**, M.A., soon after he was appointed to the livings of Owston and Withcote in 1877. Mr. **Hall** was incumbent of these parishes until 1885, when he was presented to the rectory of Manby, co. Lincoln.

PICKWELL.

SILVER CUP. Weight 21.2 oz., including lead in foot. Height 7 in. Diam. of bowl $3\frac{3}{8}$ in.; of foot $3\frac{1}{2}$ in. Height of stem $3\frac{1}{4}$ in. Date 1600. (PLATE 19.)

Hall marks. 1. Lombardic C in a plain shield. 2. Leopard's head crowned. 3. Lion passant; each with an outer line following its outline. 4. Illegible.

This is a very pretty cup, with an egg-shaped bowl, baluster stem, and flat sloping foot; under which is a large piece of lead.

TWO PEWTER PLATES. Diam. of each $9\frac{1}{2}$ each.

Marks. On the edge "P. P." for Pickwell Parish. Underneath 1. X crowned. 2. Out of a ducal crown an eagle rising to sun in splendour. 3. "London." 4. In four small shapes (a) "B. V." (b) Sun in splendour. (c) Eagle's head erased. (d) Per chevron engrailed three eagles' heads erased.

* Parish Register.

PEWTER FLAGON. Height $9\frac{1}{2}$ in. Diam. at top $3\frac{1}{2}$ in.; at the foot $4\frac{1}{2}$ in. Mark under foot; an arrow between l. S., within a dotted circle.

This is a straight-sided flagon narrowing to the top, with a flat top to its lid surmounted by a small knob. The purchase is pierced in the shape of a heart.

The lord of the manor of Pickwell in 1600, was **William Cave**, eldest son of **Richard**, who was the fifth son of **Thomas Cave**, of Stanford.

QUENIBOROUGH.

SILVER CUP. Weight 10.2 oz. Height $7\frac{1}{2}$ in. Diam. of the bowl and of the foot $3\frac{5}{8}$ in. Height of stem $3\frac{1}{2}$ in. Date 1785.

Hall marks. 1. Small Roman K in a square shield. 2. Leopard's head crowned in an oval shield. 3. Lion passant in a plain oblong. 4. Head of **George III.** in intaglio. 5. H., I. B. R., script letters, the last three being in monogram, within a plain oblong.

This cup has an egg-shaped bowl, and a thin round stem swelling out to the bowl and into a plain round foot. Round the top of the stem and on the foot is a beaded moulding. On the bowl is "*The Gift of J. P. Hungerford, Esq., of Dingley Hall, 10th July, 1807.*"

SILVER PATEN. Weight 7.2 oz. Diam. $6\frac{1}{4}$ in. Date 1774.

Hall marks. 1. Capital old English T in a square shield. 2. Leopard's head crowned in an oval shield. 3. Lion passant in a plain oblong. 4. R. I., a pellet between the letters, in a shaped shield.

This paten, originally a salver, is hexagonal in shape, with a beaded moulding round its edge. It stands upon three feet, each being an eagle's claw holding a ball. In the centre is the same inscription as that on the cup.

SILVER FLAGON. Weight 23.7 oz. Height 12 in. Diam. at the top $2\frac{1}{4}$ in. At the foot $3\frac{5}{8}$ in. Date 1791.

Hall marks. 1. Small Roman Q in a square shield. 2. Leopard's head crowned in an oval shield. 3. Lion passant in a plain oblong. 4. Head of **Geo. III.** 5. H. C. in an oblong with the corners clipped; the mark of *Henry Chawner*.

This is a jug-shaped flagon; originally a coffee pot. It has octagonal shaped sides and foot. Its handle is of ebony. Round the upper part of the flagon are bands of engraved foliage and this inscription; "*The Gift of John Peach Hungerford, Esq., of Dingley Hall in the county of Northampton, 1808.*" Below, both on the right and left, is an imperial mantle charged with the donor's crest; *On a wreath; a garb Or between two sickles erect proper surmounted by a ducal coronet of the first.**

TWO SILVER PLATED COLLECTING BASINS. Diam. of each 10 in.

In the centre of each is the sacred monogram within a quatrefoil. Round the edge of one is; "*He that giveth to the poor lendeth to the Lord.*" And round the edge of the other; "*It is more blessed to give than to receive.*"

* The position of the latter must have been a mistake of the engraver; see *infra*.

The donor of this silver communion service sprang from the ancient Wiltshire family of that name being the last heir male of the **Hungerfords**, of Windrush, co. Oxford, a branch of the **Hungerfords**, of Hungerford Wilts. :* he was the son of **John Hungerford**, of Combe Bisset, Wilts, by his wife, **St. John**, daughter and co-heir of Sir **John Topp**, Bart., of Tormarton, co. Gloucester, and was born in 1719, at Leicester as it is said.† His father, who lived once at Wigston, in this county, and afterwards in Market Harborough, died early, leaving a young widow who married in 1722,‡ **Thomas Peach**, a solicitor in Market Harborough,§ by whom she subsequently had two children who died of the small-pox. **John Hungerford**, as he then was, went to school at Rugby, and from thence was placed under Mr. **York**, a lawyer at Thrapstone. He afterwards obtained the appointment of Clerk to the Judges, and travelled the circuit, living at that time in Bedfordshire. Meanwhile his step-father, Mr. **T. Peach**, had acquired Dingley Hall and estates from the Rev. **Edward Griffin**, rector of that parish, who had inherited that property from his father, **Edward**, last Lord **Griffin**, of Braybrooke, who died without legitimate issue in 1742. Mr. **Hungerford** went to reside with his step-father at Dingley; who bequeathed to him at his death in 1770, the whole of his property on condition he took the name of **Peach** in addition to his own. In 1772, Mr. **J. P. Hungerford** served the office of high sheriff for this county, and in 1775 was elected one of the members of parliament for Leicestershire, after an exceptionally severe contest: he represented the constituency until 1790. He was connected with Queniborough inasmuch as he had purchased the manor, and a considerable portion of the land in this parish. He was also lord of the manor of Little Bowden, and owner of land in Thorpe Langton, and South Croxton. He died unmarried at Clifton, near Bristol, on the 4th June, 1809, and was buried at Dingley on the 23rd.||

Upon the West wall of the North aisle of that church is a white marble monument to his memory, at the foot of which is this coat of arms; *Sable two bars Argent in chief three plates*; Crest: *Out of a ducal coronet a garb Or between two sickles erect proper*; **Hungerford**. In the year after he came into his step-father's property Mr. **Hungerford** repaired Dingley church, placing therein most of the present windows.|| Mr. **Hungerford** bequeathed his property to **Henry**, the eldest son of the Rev. **Thomas Holdich**, rector of Burton Overy, a distant connection of his step-father's, Mr. **Thomas Holdich's** mother being **Anne Peach**, a great-niece of **Thomas Peach**. **Henry Holdich**, who was a child at Mr. **J. P. Hungerford's** death, took his benefactor's name upon reaching the age of 21: he was the father of the present Mr. **H. V. F. Holdich Hungerford**, who sold Dingley to Viscount **Downe**, in 1883.

* *Hungerfordiana*, by Sir R. C. Hoare, Bart. † In an account of Dingley and its owners, written in the parish register by Edward Griffin, rector, 1833. ‡ Son of Thomas Peach, bailiff to Lord Winchelsea at Kirby. § Marriage bond at Leicester, dated 19th Nov. 1722: to be married at Billesdon. || Parish Register.

THURMASTON.

SILVER CUP. Weight 5.2 oz. Height 5 $\frac{5}{8}$ in. Diam. of the bowl 3 $\frac{3}{8}$ in.; of the foot 2 $\frac{7}{8}$ in. Height of the stem 2 $\frac{5}{8}$ in. Date *circa* 1575. (PLATE 19.)
One mark only, a rose.

This cup, like others of this series, has a bowl shaped into an inverted truncated cone, with concave sides and a flat projecting base, and an evenly-balanced stem, divided in half by a thin knob. Its foot is rather higher than usual. Round the bowl is a band of foliage, divided into four parts by hour-glass curves. Both ends of the stem and the edge of the foot are reeded.

SILVER PATEN with a foot. Weight 2.6 oz. Diam. 4 $\frac{1}{4}$ in. Diam. of the foot 1 $\frac{7}{8}$ in. Height of the foot $\frac{3}{8}$ in. Date *circa* 1615. (PLATE 19.)

One mark only, the maker's, P. W., the P rising above the W, within a shaped shield, in each of the three corners of which is a mullet.

This paten has a flat edge, the middle part being sunk flat. The foot is a disk, attached to the paten by a stem swelling out at both ends. A line runs round the edge of the paten at the top, and also round the foot. The paten fits on to the cup with the foot downwards, and has no appearance of ever having been a cover.

TWO PEWTER PLATES. Diam. of each 9 $\frac{1}{2}$ in.

Marks. 1. X crowned. 2. "Made in London." 3. Within an ornamental oblong, a lion rampant, "W. Cooke," above. 4. A rose crowned, within a similar oblong.

TILTON.

(b)

SILVER CUP WITH COVER PATEN. Weight of cup 18.5 oz. Height 8 $\frac{1}{4}$ in. Diam. of bowl 4 $\frac{3}{4}$ in.; of foot 5 in. Height of stem 3 $\frac{3}{4}$ in. Date 1671. (PLATE 22.)

Hall marks. 1. Capital old English O in a plain shield. 2. Lion passant. 3. Leopard's head crowned, each of the two last having an outer line following its outline. 4. R. D., a quatrefoil between, two pellets below, in a plain shield.

This cup has a straight-sided bowl with a flat base, and a conical stem swelling out into the foot, which is rounded off into a flat edge. The bowl is not all of one piece, for the bottom is a separate plate, held in position by the sides of the bowl being turned inwards underneath it; a second circular plate is fixed on the bottom of the bowl, outside; to this is fastened the top of the stem, which with the foot is beaten out of one piece of silver. Round the middle of the bowl is "*Calix Benedictionis*." On the top of the foot is: "*Jocosa Pauley and Friswid Chamberlaine mensæ Dominicæ legarunt.*"*

SILVER COVER PATEN with a foot. Weight 5.4 oz. Diam. 5 $\frac{1}{2}$ in. Diam. of foot 2 $\frac{3}{8}$ in. Height of foot 1 in. Date 1671. (PLATE 22.)

Hall marks as on cup.

This cover paten has a flat edge, from which the middle part is sunk flat. The foot is a disk, attached to the paten by a conical stem.

* "*Jocosa Pauley and Friswid Chamberlaine bequeathed this to the Lord's table.*"

(a)

SILVER PATEN with a foot. Weight 6 oz. Diam. 6 in. Diam. of the foot $2\frac{1}{4}$ in. Height of foot 1 in. Date 1661. (PLATE 22.)

Hall marks. 1. Capital old English D in a plain shield. 2 and 3. As on cup. 4. T. L., a pellet between the letters above and below, within a plain oblong, corners clipped.

This paten has a flat edge, from which the middle part is sunk flat. The foot is a disk, attached to the paten by a stem swelling out at both ends. On the edge in Roman capitals is "B. C.," opposite to which is: "*Hoc est corpus meum.*"

(c)

SILVER FLAGON. Weight 29.8 oz. Height 9 in. Diam. at top $4\frac{1}{8}$ in.; at foot $5\frac{7}{8}$ in. Date 1670. (PLATE 22.)

Hall marks. 1. Capital old English N in a plain shield. 2, 3, and 4. As on cup.

This is a straight-sided flagon, narrowing to the top. Its lid is nearly flat, being rounded off into a flat projecting edge. The purchase is pierced in the shape of a small heart. In front is: "*Vasculum hoc mensæ Dominicæ Sacrum esse Vultire Georgius & Sara Chamberlain.*"* Under the foot is the lion passant, and this weight: "30 oz. less 1 wtt. 12 gr."

(d)

SILVER CUP. Weight 4.4 oz. Height $5\frac{3}{8}$ in. Diam. of bowl $2\frac{3}{8}$ in.; of foot $2\frac{3}{4}$ in. Height of stem $2\frac{1}{2}$ in. Date 1712.

Hall marks. 1. Court hand R. 2. Lion's head erased. 3. Britannia. 4. G. A., a crown between two pellets above, two pellets between the letters, within a dotted circle. The mark of *William Gamble*.

This is a small cup, with a straight-sided bowl rounded off at the base, having a slightly bell-shaped lip. Its stem, which is evenly balanced, has in its middle a knob formed by a round moulding between two hollows; both ends of the stem swell out. The foot ends in a round moulding and a flat edge. This little cup is made out of two pieces of metal only.

FOUR BRITANNIA METAL PLATES. Diam. of each $9\frac{1}{8}$ in.

Marks. 1. X crowned. 2. Out of a ducal crown a horse's jamb. 3. "London." 4. In four small shapes: (a) R. and S. (b) A device. (c) On a fesse three escalops. (d) Lion's head.

(a)

Here is a service given by a mother and four of her children; for "B. C." the donor of the paten, I believe to have been **Bridget Chamberlaine**; she giving that piece to this church in the year her husband's will was proved. This lady, who was according to *Nichols* (Vol. iii., p. 475.) the daughter of — **Fitzwilliams**, had by her husband **William Chamberlaine**, a well-to-do yeoman of this parish, five sons and six daughters. She was buried at Tilton on 3rd June, 1665.† Her husband was buried at Tilton on the 10th June, 1651.†

His will made on the 2nd June, 1649, was not proved in Leicester till 13th April, 1661. He bequeathed £300 to his wife **Bridget**, and legacies to the following members of his family; his son-in-law **R. Pawley** and his wife; his son-in-law **F. Nedham** and his wife; his sons **William** and **George**; his daughters **Sarah**, **Mary**, and **Friswid Chamberlaine**; his sister **Jocosa Sherwood**. His eldest son **Francis** sole executor.

* "George and Sarah Chamberlaine purposed this vessel to be sacred to the Lord's table." † Parish Register, which begins in 1610.

(b)

The donors of the large cup and cover paten were two younger daughters of the above **William and Bridget Chamberlaine**. **Joyce**, the elder of the two, was born at Tilton on the 21st and baptized on the 24th of June, 1612.* She married in 1648, as his second wife, **Robert Pawley** of Scraftoft, a well-to-do yeoman, owning land in that parish and in South Croxton, as well as in the borough of Leicester. He had married, first at Scraftoft on the 25th Oct., 1638, **Elizabeth**, daughter of **Julius Billers**, of Leicester; which lady, having borne him several children, died in 1647.† By his wife **Joyce Chamberlaine**, **Robert Pawley** had two daughters, **Bridget**, baptized at Scraftoft on 19th Nov., 1648, and **Joyce**, baptized on 4th Aug., 1650.‡ Mrs. **Joyce Pawley** was living in 1680, the year in which her sister **Dorothy Nedham** made her will;‡ soon after which date I imagine she died, having apparently bequeathed a sum of money for the part purchase of this cup and cover, bought about ten years after it had been made.

The other sister and co-donor, **Friswid**, was born at Tilton on the 6th, and baptized on the 13th of Jan., 1616.* This lady who never married, was buried at Tilton on the 11th June, 1680.* Her will was made on the 7th Sep., 1670, and proved P.C.C. 10th Sep., 1680. She bequeathed “£3 6s. 8d., to buy a carpet and a diaper table-cloth and a napkin for the communion table in Tilton church;” which bequest the vicar and churchwardens seem to have expended in the part purchase of this cup and cover instead of in coverings for the altar; with which the church had probably been already provided.

Friswid Chamberlaine left £10 to the poor of this parish, and the following legacies, amongst others, to her family; £40 each to her “widowed” sisters **Elizabeth Armstrong**, **Dorothy Nedham** and **Jocosa Pawley**; £50 each to her spinster sisters **Sarah** and **Mary**, together with the goods and plate given to her by her late brother, Dr. **William Chamberlaine**; § £20 to her brother **Francis**, and £100 to her brother **George**. In a codicil dated 12th Aug., 1677, legacies are left to various nephews and nieces.

(c)

The joint donors of the flagon were the second son and another daughter of the above **William and Bridget Chamberlaine**. **George** was born in about 1603, and matriculated as a sizar at Trinity Coll., Camb., on 2nd March 1621, from whence he took his B.A. in 1625, M.A. 1629, S.T.P. 1661. The Rev. **George Chamberlaine** was elected to a senior fellowship at Trinity on 17th March, 1628-9, and in his college spent the greater part of a long life; he was ejected from his post by the parliament party,|| but survived the troubles, regaining his own again in 1660. On 3rd Dec., 1666, he was elected Vice-Master. His name appears for the last time in the College records in

* Parish Register. † Parish Register. ‡ *Vide* p. 261. § Prebendary of Windsor: baptized at Tilton on 27th Sep., 1619. || Walker's *Sufferings of the Clergy*, 1714, p. 160.

1687, but he may have lived a little later, for no successor was appointed to the Vice-Mastership till 1690.*

The other donor of the flagon was **Sarah**, one of the elder daughters of **William** and **Bridget Chamberlaine**. She remained single and was buried at Tilton, on 12th Sep., 1670.† If her will could be found it would probably show that her share of this gift was made in the form of a bequest.

(d)

Nothing is known of the origin of the little cup which was probably given for the administration of the Holy Communion to the sick.

WITHCOTE.

SILVER CUP AND COVER PATEN. Weight of cup 24.3 oz. Height 9½ in. Diam. of bowl 5 in.; of foot 4¾ in. Height of stem 4½ in. Date 1683. (PLATE 22.)

Hall marks. 1. Small black-letter F in a plain shield. 2. Leopard's head crowned in a circle. 3. Lion passant in a plain oblong. 4. I. B., a stag courant above, within a shaped shield.

This is an unusually heavily made cup. Its bowl is straight-sided in shape, with a flat base and a raised lip. Its stem is divided in half by a round knob from which it swells straight out to both ends. The foot is finished off with a round moulding and a flat edge. On the bowl is the sacred monogram with a cross and three nails, within a circle of glory, and on the foot is: "*Ex dono Mathei Johnson, ad usum Ecclesie de Withcot.*"

SILVER COVER PATEN with a foot. Weight 9.1 oz. Diam. 6 in. Diam. of the foot 2¾ in. Height of foot ¾ in. Date 1683. (PLATE 22.)

Hall marks as on the cup.

This paten has a flat edge, the middle part being sunk flat. The foot is a disk attached to the paten by a stem swelling out to both ends. On the foot is the sacred monogram; and underneath the paten is the same inscription as that on the cup.

SILVER DISH with a foot. Weight 9.6 oz. Diam. 6½ in. Diam. of foot 3¾ in. Height of foot 1¾ in. Date 1683. (PLATE 22.)

Hall marks as on the cup.

This is a flat dish with a vertical edge. In the centre is the sacred monogram. The foot is hollow. Underneath the dish is the same inscription as that on the cup.

SILVER FLAGON. Weight 13.9 oz. Height 10¾ in. Diam. of the top 2¼ in.; of the foot 3½ in. Date 1877.

London hall marks.

This is a plain and good jug-shaped flagon. In front is the sacred monogram within an ornamental circle. The lid is surmounted with a double cross. Underneath the foot is: "*Withcote Church, 1877.*"

Matthew Johnson, the donor of the older pieces of communion plate, was the eldest son of **Templer Johnson**, a yeoman of Gretton, co. Northants, by **Elizabeth**, his wife, and was baptized at Gretton, on 8th Sep., 1637.‡ He owed his success in life through having "had his education" under his

* Registers of Trin. Coll. Camb. † Parish Register. ‡ Parish Register. "Templer Johnson, buried 30th Aug., 1661," and "Elizabeth Johnson, widow, buried 29th Jan., 1663."

father's near neighbour, and possibly landlord, Sir **Geoffrey Palmer**, Bart., of East Carlton, attorney-general to **Charles II.** Through Sir **Geoffrey's** influence, **Matthew Johnson** was admitted to the Middle Temple as a student, on 29th July, 1662: he was called to the bar on 2nd June, 1671.* He afterwards obtained the post of clerk of the parliaments, and held that office for twenty-six years. Early in the reign of **Charles II.**, Mr. **Matthew Johnson** bought the lordship of Withcote from the Earl of **Rochester**, to whom it had been given by the king, upon the attainder of its former owner, **Henry Smith**, who was deprived of it for having taken part in the execution of **Charles I.** Mr. **Johnson** was also the purchaser of one of the manors of Owston, and of the manor of Thorpe Lubenham. He married at Kirby Bellars, † on 4th Sep., 1676, the grand-daughter of his patron, **Margaret**, the only daughter of **Edward Palmer**, of Stoke Doyle, by **Elizabeth**, the eldest daughter of Sir **Geoffrey Palmer**, 1st Bart.

Of this marriage, two sons and two daughters were born; **Geoffrey**, the eldest, succeeded his father, and died unmarried in 1742, aged 64; **Matthew**, clerk assistant of the House of Lords, died unmarried, aged 42, on the 22nd May, 1725, and was buried in Westminster Abbey, on the 25th; **Frances**, married on 13th July, 1725, at St Giles', Cripplegate, **James Merest**, clerk assistant of the House of Lords, and died without issue, on 14th Nov., 1727, aged 40, being buried at Westminster Abbey on the 17th; **Elizabeth**, who was her brother's heir, died unmarried in 1754, aged 67.

Mr. **Matthew Johnson** himself, died on 13th December, 1723; his wife, **Margaret**, on 19th Sep., 1715, aged 67: they were both buried in Withcote church, in which, at the South East corner, is a grey marble monument to their memory, with these arms at the top; *Argent on a bend Gules three pheons Or a canton Ermine*; **Johnson**; *impaling azure a chevron engrailed between three crescents Argent*; **Palmer** of Stoke Doyle. ‡

At the death of his daughter **Elizabeth**, **Matthew Johnson's** property passed to his wife's nephew **Edward Palmer** of Stoke Doyle, who died unmarried in 1770, when this lordship of Withcote and the manor at Owston were inherited by Sir **John Palmer**, 5th Bart., of Carlton park, Northants, and Carlton Curliu in this county, from whom it passed to his son Sir **John**, who in 1843 exchanged it for the Carlton Curliu estate with his younger brother the late Rev. **Henry Palmer**, whose third but eldest surviving son, **Frederick Palmer**, Esq., formerly Lieutenant-Colonel of the Leicestershire Yeomanry, is now the honoured possessor of it. It is worth mentioning that the original grant of arms given to **Matthew Johnson** in 1707, by Sir **Henry St. George**, Garter, is in the possession of the present owner of Withcote; on which grant the arms are blazoned as on his monument and also the crest, "on a wreath of his colours a *demi griffin Gules collared Ermine, holding between his claws a pheon Or.*" **Matthew Johnson** bequeathed a rent charge of £2 a year on forty-three acres of land owned by him at Gretton, to apprentice poor children of his native parish; which sum is now given to the poor.

The silver flagon was presented to this church by **Frederick Palmer**, Esq.

* Middle Temple Records. † He was married at this place because his wife's aunt lived here, *viz.*, Frances, youngest daughter of Sir **Geoffrey Palmer**, Bart., and wife of John de la Fontaine, of Kirby Bellars. ‡ Inscription given by *Nichols*, Vol. ii., p. 393; in which, perhaps by M. Johnson's own order, is an allusion to his obligations to Sir G. Palmer.

GOSCOTE SECOND DEANERY.

ASFORDBY.
BROOKSBY.
COSSINGTON.
DALBY MAGNA.
DALBY-ON-THE-WOLDS.
FRISBY-ON-THE-
WREAKE.

HOBY.
ROTHERBY.
PRESTWOLD.
HOTON.
RAGDALE.
RATCLIFFE-ON-THE-
WREAKE.
REARSBY.

SAXELBYE.
SEAGRAVE.
SILEBY.
SYSTON.
THRUSSINGTON.
WALTON-LE-WOLDS.
WYMESWOLD.



ASFORDBY.

SILVER CUP. Weight 5.2 oz. Height 6 in. Diam. of the bowl 3 in.; of the foot $2\frac{7}{8}$ in. Height of stem 3 in. Date 1622. (PLATE 20.)

Hall marks. 1. Italic E in a plain shield. 2. Lion passant. 3. Leopard's head crowned; each within a line shaped to the mark. 4. An illegible mark within an ornamental circle.

This little cup has a bell-shaped bowl standing upon a baluster stem which rises out of a flat sloping foot. On the bowl is; "*William and Leonard Gregory gave this.*"

SILVER CUP. Weight 13.6 oz. Height $7\frac{1}{2}$ in. Diam. of the bowl $3\frac{3}{4}$ in.; of the foot $4\frac{3}{8}$ in. Height of stem $4\frac{3}{4}$ in. Date 1861.

Birmingham hall marks.

This cup has a V shaped bowl, a round stem with a large ornamental knob and a plain round foot. Round the bowl is; "*Drink ye all of this.*" Under the foot is; "*The Parish Church of All Saints, Asfordby, A.D., 1862.*"

SILVER PATEN. Weight 6.5 oz. Diam. $6\frac{1}{4}$ in. Date 1862.

This paten has a flat edge round which is; "*Take, eat, this is my body.*" In the centre is a cross patée.

SILVER FLAGON. Weight 23.2 oz. Height $10\frac{3}{4}$ in. Diam. at the top $2\frac{1}{4}$ in.; at the foot $2\frac{3}{4}$ in. Date 1861.

This is a jug-shaped flagon with a wide middle narrowing into a tall thin neck. Round the middle is; "*This is my blood.*" Underneath the foot is the same inscription without the date as that under the cup; this is also placed underneath the paten.

There formerly belonged to this church as we learn from the terrier of 1824, another little silver cup weighing slightly more than 6 oz. This was about the same in shape as the first one, and had had a wooden stem put into it and was altogether much out of repair; it was sold in 1862, together with "a great pewter flagon and two pewter plates."

Not much can be said about the donors of the ancient cup still here. They sprang from an old Leicestershire family said to have been seated here in the 13th century.* From a certain **John Gregory** were descended, through many generations, two brothers, **Thomas** and **William**, who died in the middle of the 16th century; the eldest of these migrated to Styvechale, co. Warwick, and is the ancestor of Major **Francis Hood Gregory** of that place, the second brother remaining on at Asfordby, was the father of **William Gregory** of this parish, who by his wife **Frances**, daughter of **John Baker**, of Eaton, co. Leicester, had two sons **William** and **Leonard**, who may have been the donors of this cup.

The three modern pieces of plate were presented by the Rev. Canon **J. Cartmell** and the communicants of this parish at a cost of about £40.

BROOKSBY.

SILVER CUP. Weight 14 oz. Height $8\frac{1}{4}$ in. Diam. of the bowl $4\frac{1}{8}$ in.; of the foot $3\frac{7}{8}$ in. Height of stem $4\frac{1}{4}$ in. Date **1624**. (PLATE 22.)

Hall marks. 1. Italic G in a plain shield. 2. Lion passant. 3. Leopard's head crowned, each within an outer shaped line. 4. A dexter hand with a cock perched on the first finger, within a plain shield.

This cup has a bowl shaped into an inverted truncated cone with a flat base. Its stem is evenly balanced being divided in half by a large round knob from whence it swells to the bowl and into a raised foot under which the lion passant is repeated.

SILVER PATEN with a foot. Weight 4.5 oz. Diam. $5\frac{1}{8}$ in. Diam. of foot $2\frac{3}{8}$ in. Height of foot 1 in. Date **1624**. (PLATE 22.)

This paten, which is stamped with the maker's mark only, as on the cup, has a flat edge from which the middle part is sunk flat. The foot is a disk attached to the paten by a stem swelling out at both ends. The paten fits on to the cup with its foot downwards.

PEWTER DISH. Diam 11 in.

Marks. 1. On back, an anchor between R. L. within a serpent shaped into a circle. 2. On the edge, E. C. 3. In a shaped shield a stiff fleur-de-lis repeated twice. 4. In a similar shield R. L. repeated twice.

This is a basin-shaped dish with a flat edge.

TWO PEWTER PLATES. Diam. of each $9\frac{1}{4}$ in.

Marks on each. 1. An eagle displayed, "**Hodgkin**" below.

In 1624 Sir **William Villiers**, Knt., was the owner of Brooksby and of adjoining property; he was the eldest brother of the Duke of **Buckingham**, the favourite of **James I.**, and **Charles I.**

* Visitation of 1619, *Pub. of Harl. Soc.*, Vol. ii., p. 187.

COSSINGTON.

(a)

SILVER CUP AND COVER PATEN. Weight of Cup 10.7 oz. Height 6 $\frac{3}{4}$ in. Diam. of the bowl and foot 4 in. Height of stem 3 in. Date 1683. (PLATE 23.)

Hall marks. 1. Small black-letter F in a plain shield. 2. Leopard's head crowned in a circle. 3. Lion passant in a plain oblong. 4. M. K., a mullet below in a heart-shaped shield.

This is a solid cup with a straight-sided concave bowl, and a thick round stem swelling out to the bowl and into a plain foot round which run a few mouldings. Under the foot is the lion passant and "*S.* 1684."
W. A.

(b)

SILVER COVER PATEN with a foot. Weight 4.8 oz. Diam. 4 $\frac{1}{2}$ in. Diam. of the foot 2 $\frac{1}{4}$ in. Height of foot $\frac{5}{8}$ in. Date 1704. (PLATE 23.)

Hall marks. 1. Court-hand I. 2. Britannia. 3. Lion's head erased. 4. Capital Roman G, and a small black-letter I, some mark above, in a shaped stamp.

This paten has a flat edge, the middle part being sunk flat. The foot is a disk attached to the paten by a very wide and short stem. On the foot is "*W. S.*, 1704."

SILVER DISH with a foot. Weight 16.7 oz. Diam. 9 $\frac{3}{4}$ in. Diam. of the foot 3 $\frac{3}{4}$ in. Height of foot 2 $\frac{1}{2}$ in. Date 1703. (PLATE 24.)

Hall marks. 1. Court-hand H. 2, 3, and 4, as on cover paten.

This is a plain flat dish with a gadrooned edge. Its foot is a hollow drum 2 in. thick swelling out into a gadrooned and flat edge. Underneath is "*W. S.*, 1704;" the foot being stamped with the lion's head erased.

(c)

SILVER CUP. Weight 10.7 oz. Date 1851.

London hall marks.

This cup is the same in size and shape as the old one. Under the foot is "*M. F. B.*, Dec. 19, 1851."

(d)

SILVER PLATED FLAGON. Height 10 $\frac{1}{2}$ in. Diam. at the top 1 $\frac{3}{8}$ in.; at the foot 4 in.

This is a plain jug-shaped flagon, with a cross patée for a purchase.

The three first pieces of plate are mentioned in the terrier of 1762, and also "a great pewter flagon;" which was no longer here in 1832.

(a)

I am inclined to think that the initials on the first cup stand for **William** and **Anne Staveley**, in memory of whom it may have been presented to this church, by one or more of their children; or it may have been substituted for a piece of plate formerly given by them. **William Staveley**,* a descendant of the **Staveleys** of Bignell, Oxon., and of Langton, Leicestershire, was rector of this parish from 1625 till his death on 14th

* For an account of this family see *Nichols*, Vol. ii., p. 676.

Aug., 1652, at the age of 55: a marble monument to his memory, bearing a long inscription, is on the North wall of the chancel. His wife was **Anne**, the second daughter of **Thomas Babington**, of Rothley Temple; they were married on 12th Jan., 1625; she died in 1680.

(b)

The initials on the cover paten and dish, stand no doubt for **William Staveley**. These two pieces must have been bought after his death, either in accordance with verbal instructions previously given by him, or else at the discretion of his trustees. **William Staveley** was the second son of the above-named **William** and **Anne**: his elder brother, **Thomas**, was the author of MSS. relating to the history of Leicester. Mr. **W. Staveley** succeeded his father in the rectory of Cossington, which he held till his death on 18th Feb., 1703, in the 76th year of his age.

He died unmarried, and by his will made on 21st Sep., 1702, and proved in Leicester in 1704, left the principal part of his estate to charitable purposes. Small legacies were left to his three sisters, **Elizabeth Hagman**, **Martha Hungerford**, and **Mary Sibbalds**, and also to his servants, the remaining part being left to three trustees to be devoted to the following purposes; to the rector of Cossington for the time being, the rents of two plots of land called Thurnwater nook, and Thurnwater close, and of a cottage and outhouse in this parish. To the rector and wardens of this parish on St. Thomas' Day yearly, £2, to buy bread and beef for the poor, and £1 on the same day to the vicar and wardens of Rothley for bread for the poor of that parish. To the incumbent of Mounsthorrel on Whit-Sunday yearly, £2. To a preacher appointed by his trustees for a sermon "exhorting to charity," preached in Trinity Hospital, Leicester, on Whit-Monday £1; the same sum to be paid towards the collection for the poor of that hospital on the same day. To the school at Sibley £4 on each Easter Monday; and on the same day to the incumbent of Sibley, the whole surplus of the rents of all his present property, and of any more that may be purchased. The Rev. **William Staveley** was buried in the chancel of Cossington church; over his grave is a slab, on which is an inscription in latin which thus describes his character; "*vixit sobriè, justè, piè, hospitalitèr; omnem virtutem coluit, præsertim Charitatem.*"* The arms of **Staveley** are; *Argent on a chevron Azure, between three lozenges Sable, as many stags' heads caboshed, Or.* Crest; *A stag's head coupèd affronté.* Motto; "*Patiur ut potiar.*"

(c)

The modern silver cup was given in memory of his wife, by the Rev. **John Babington**, second son of **Thomas Babington**, of Rothley Temple, M.P., by **Jean**, daughter of the Rev. **John Macaulay**. Mr. **Babington**, who was born on 6th July, 1791, was for many years a much honoured clergyman of this county. He graduated from Magd. Coll. Camb.; and was in 1810 presented by his father to the rectory of Cossington, which he held till 1859. From 1867 to 1873, he was rector of Walton-le-Wolds. He latterly resided at 10, Norfolk Terrace, Brighton, and there died without issue on 6th Oct., 1885, and was buried at Hove: he had been an Honorary Canon of Peterborough

* "He lived soberly, justly, piously, hospitably: he cultivated every virtue, especially Charity." For rest see *Nichols*, Vol. iii., p. 229.

from 1847. Mr. **Babington** was twice married: first on 21st April, 1818, at Paston, to **Maria Frances**, eldest daughter of the Rev. **Joseph Stephen Pratt**, B.C.L., by **Frances Cecilia**, eldest daughter of Major **Cowper**, of Park House, Hertingfordbury; this lady who was born on 10th June, 1783, died at Leamington on 19th Dec., 1851, and was buried at Cossington. Her husband married secondly, at Clifton parish church, in Aug., 1855, **Eleanor**, fifth daughter of **Charles** and **Eling Elliott**, who was born on 13th Nov., 1795, and died on 20th March, 1884, being buried at Hove.

(d)

The silver plated flagon was the gift of **J. R. Edmonds**, Esq., of Sileby.

DALBY MAGNA.

SILVER CUP AND COVER PATEN. Weight of cup 8.5 oz. Height $6\frac{3}{8}$ in. Diam. of bowl $3\frac{3}{8}$ in.; of foot $3\frac{1}{2}$ in. Height of stem 3 in. Date 1772.

Hall marks. 1. Capital old English R in a square shield. 2. Leopard's head crowned in an oval shield. 3. Lion passant in a plain oblong. 4. T. W., with a pellet between, in a plain oblong.

This cup has a straight-sided bowl rounded off below, with a bell-shaped lip; a straight round stem with a small moulding for a knob and a plain round foot. Upon the bowl is "*Thos. Leadbeater, Wm. Blower, Dalby Magna, Churchwardens, 1772.*"

SILVER COVER PATEN with a foot. Weight 4.7 oz. Diam. $3\frac{1}{8}$ in. Diam. of foot $1\frac{3}{4}$ in. Height of foot $1\frac{1}{8}$ in. Date 1772.

Hall marks as on cup.

This is a flat paten with a vertical edge $\frac{1}{2}$ in. deep. The foot is a disk attached to the paten by a stem swelling out to both ends.

PEWTER FLAGON. Height $10\frac{5}{8}$ in. Diam. at the top $4\frac{7}{8}$ in.; at the foot $6\frac{7}{8}$ in. Date 1671.

Mark on the bottom inside; dove with an olive branch, "R. B." above, "1671" below, in a circle.

This is a conical-shaped flagon, narrowing straight up from the foot. Round the top, the middle and the foot is a narrow flat moulding. The lid is a flat disk projecting $\frac{1}{2}$ in. over the drum. Round the lid inside is a rim to cause the lid to fit on to the drum. Upon one side of the drum is; "*Dalby Chalcomb, 1734.*"

The second churchwarden named on the cup was a native of this place being the son of **William Blower**, by his wife, **Anne**, the daughter of **William** and **Ann Hodgkin**, and was baptized here on 29th Dec., 1687. He died on 21st Nov., 1773, and was buried in this churchyard, a headstone bearing a poetical inscription marking his grave.

DALBY-ON-THE-WOLDS.

SILVER CUP WITH COVER PATEN. Weight of cup 8.2 oz., including lead in stem. Height $5\frac{1}{2}$ in. Diam. of bowl $3\frac{3}{8}$ in.; of foot $3\frac{1}{8}$ in. Height of stem $2\frac{3}{8}$ in. Date 1667. (PLATE 20.)

Hall marks. 1. Capital old English K in plain shield. 2. Lion passant. 3. Leopard's head crowned; each of the two latter marks having an outside line following its outline. 4. A. M. in a monogram in square.

This cup has a nearly straight-sided bowl with a flat base and a conical stem and foot. At the top of the stem is a disk for a knob. The lion passant is repeated underneath the foot.

SILVER COVER PATEN with foot. Weight 3 oz. Diam. $4\frac{1}{4}$ in. Diam. of foot $2\frac{3}{8}$ in. Height of foot $\frac{5}{8}$ of an inch. Date 1667. (PLATE 20.)

Hall marks as on cup.

This is the flat cover paten usual at this date, having a disk for a foot attached to the cover by a stem swelling out at both ends.

PEWTER DISH. Diam. $9\frac{1}{4}$ in.

Marks. 1. X. 2. I. C. 3. Leopard's head. 4. Lion rampant. 5. "London" over an illegible mark with "T. D. R. —" below. On the edge is "Church Plate."

The lord of the manor of this parish in 1667 was **George Villiers, 2nd Duke of Buckingham**.

Nichols mentions (Vol. iii. p. 256) that the Earl of **Radnor** presented a silver chalice and paten to this church at the end of the last century. Nothing is known of this gift by any one now living, and inquiries made with respect to it have revealed the fact that this cup and paten could not have been here at any time during Mr. **Sawyer's** incumbency which commenced in 1830. This being a donative no terrier of church goods here exists in the registry at Lincoln: and for the same reason the communion plate of this parish is not mentioned in Archdeacon **Bonney's** inventory. It is just possible that *Nichols* may by mistake have recorded Lord **Radnor's** gift as having been made to Dalby instead of to Nether Broughton. (*Vide* p. 151.)

FRISBY-ON-THE-WREAKE.

SILVER CUP. Weight 5.8 oz. Height $6\frac{1}{2}$ in. Diam. of the bowl and of the foot $2\frac{7}{8}$ in. Height of stem 3 in. Date 1568. (PLATE 20.)

Hall marks. 1. Small black letter L in a plain shield. 2. Lion passant. 3. Leopard's head crowned, each within an outer shaped line. 4. An illegible device within a shaped stamp.

This is a very pleasing little cup with a bowl shaped into an inverted truncated cone, round which are two bands of foliage divided into three parts by hour-glass curves. Its stem is evenly balanced, being divided in half by a large round knob on a fillet ornamented with rows of little horizontal strokes. The foot is of the usual shape, with reeds and the egg and tongue ornament running round its edge.

SILVER PATEN. Weight 7.1 oz. Diam. $8\frac{3}{4}$ in. Date 1713.

Hall marks. 1. Court-hand S. 2. Britannia. 3. Lion's head erased. 4. C. O., a fleur-de-lis above, within a trefoil, not very distinct; mark of *Aug. Courtauld*. This is a plain plate, on its edge is "*Ex dono Henrici Storer, Vic. de Frisby.*"

PEWTER FLAGON. Height $10\frac{1}{2}$ in. Diam. at the top 4 in; at the foot $4\frac{1}{2}$ in. No marks.

This is a straight-sided flagon, narrowing a little towards the top. Round the foot, and also round the lip is a round moulding. The lid is rounded, and is surmounted with a knob.

PEWTER PLATE. Diam. $8\frac{3}{4}$ in.

Marks. 1. Eagle displayed with "**Hodgkin**" below. 2. "London" in a shaped oblong.

The **Brokesbys**, of Shouldby, had for many years a house and property in Frisby; the representative of that family in 1568 was **Robert Brokesby**, who died in 1615. Upon the roof of the North aisle of this church are the arms of **Brokesby**; *Argent, two bars nebulé Gules on a canton of the last a mullet pierced Or; impaling a maunche.*

Henry Storer was the son of **Thomas Storer**, of Melton Mowbray, by **Ann**, his wife* and was baptized at Melton on 2nd Oct., 1657.† Having been sent to school in that town, he matriculated as a sizar at St. John's Coll., Camb., on 1st July, 1674, at the age of 17,‡ taking his B.A. from thence in 1677, and M.A. in 1681, in which year he was ordained deacon by the Bishop of **Lincoln**, on 25th Sep., and priest on 28th Dec. following.§ On 12th May, 1698, he was instituted to the rectory of Brooksby, on the presentation of Sir **William Villiers**, Bart., and on 8th July, 1703, to the vicarage of Frisby-on-the-Wreake, to which he was presented by the Queen,§ both livings were held by him till his death. Mr. **Storer** died unmarried, and was buried at Frisby-on-the-Wreake, on 20th Sep., 1721.||

By his will made on 12th Dec., 1720, and proved in Leicester on 7th Nov., 1721, he left houses and land in Melton and Frisby to Mr. **John Henley**, (the orator,) then curate of Melton, and to four other trustees, to whom he gave the power of devoting the income to the benefit of the poor of Melton in whatever way they thought best. To the poor of Frisby he left £5.

By 1740, Mr. **Storer's** trustees had increased his charity by the purchase of an oxgang of land in Nether Broughton, out of savings. At that time the income was practically amalgamated with the charity founded by **Robert Hudson**,¶ being spent in increasing the weekly allowance of the six poor people living in **Hudson's** bede-house, and in maintaining six additional poor men or women living in the same place. In 1827 the trustees enlarged Mr. **Storer's** charity by purchasing a piece of land in Rutland Street, Melton, and building thereon almshouses, which hold six poor people; doing this by means of savings, and by borrowing £400, which was paid off by 1843. This bede-house and **Hudson's**, which are still under the same management and treated as one charity, were further endowed with a sum of £500 left to each by Mr. **Thomas Ward**, in 1873.

HOBY.

SILVER CUP. Weight 6.2 oz. Height 5½ in. Diam. of the bowl 3 in.; of the foot 2¾ in. Height of stem 2¼ in. Date 1798.

Hall marks. 1. Capital Roman C in a plain shield. 2. Leopard's head crowned in a plain shield. 3. Lion passant. 4. Head of King **George III.** 5. E. T. in an oblong.

This little cup has a straight-sided bowl with a moulding running round its lip, a short round stem divided in half by a narrow moulding and a plain round foot.

* "Thomas Storer and Ann Briggs married 24th Sep., 1653." Melton Parish Register. + Ibid. † St. John's admission book, in which his father is called a "brasier." § Bishop of Lincoln's registers. || Parish Register. ¶ Page 165.

PEWTER PATEN, silver plated, with a foot. Diam. 8 in. Diam. of the foot $4\frac{1}{2}$ in. Height of foot $2\frac{1}{2}$ in.

No marks.

This is a modern flat paten standing on a large moulded foot.

PEWTER PLATE with a foot. Diam. $9\frac{1}{2}$ in. Diam. of the foot 4 in. Height of foot 2 in.

Marks. 1. H. C. for Hoby Church. 2. An illegible device with a name below ending in "— bank," repeated twice.

This is a flat plate with a raised edge; standing on a very rudely shaped foot, a hollow inverted truncated cone. It was formerly used as a paten.

PEWTER PLATE. Diam. $9\frac{1}{4}$ in.

Marks. 1. H. C. 2. Leopard's head; the others being obliterated.

PEWTER FLAGON. Height $11\frac{3}{4}$ in. Diam. at the top 4 in.; at the foot $5\frac{3}{4}$ in.

Marks. 1. X. crowned. 2. In four small shields: (a) Lion rampant. (b) Possibly a buckle. (c) Leopard's head. (d) Capital old English C.

This is a straight-sided flagon narrowing towards the top. It has a raised lid surmounted by a knob and an R shaped handle. In front is "Hoby."

In the terriers of 1730 and 1745, the church plate here is thus described; "a small silver cup about 5 oz.; a pewter flagon."

ROTHERBY.

SILVER CUP. Weight 14.7 oz., including lead in the stem. Height $6\frac{1}{4}$ in. Diam. of the bowl $3\frac{1}{2}$ in.; of the foot 3 in. Height of stem $3\frac{3}{8}$ in. Date 1568. (PLATE 20.)

Hall marks. 1. Small black letter L in a plain shield. 2. Lion passant. 3. Leopard's head crowned, each within an outer shaped line. 4. I. F. in a square.

This is a pretty cup having a bowl shaped into an inverted truncated cone round which is an unusually wide band of foliage divided into four parts by hour-glass curves. The stem is an evenly-balanced one, being divided in half by a round knob on a fillet from whence it swells to both ends into a vertical edge ornamented with reeds. The foot is rounded off into a flat edge.

PEWTER PATEN, silver plated, with a foot.

Just like the first one at Hoby.

PEWTER PLATE. Diam. $9\frac{1}{4}$ in.

Marks. 1. Rose between two sprays crowned. 2. "London," on a scroll.

This plate was silver-plated a few years ago, at which time the cup was slightly repaired, and its stem then filled with lead.

In two terriers at Lincoln dated 1724 and 1745, a cover is mentioned as belonging to the cup of this parish, both together weighing 9 oz. 12 dwts. This cover had disappeared before 1832.

PRESTWOLD.

(a)

SILVER CUP. Weight 10.2 oz. Height $7\frac{1}{8}$ in. Diam. of the bowl and of the foot $3\frac{1}{8}$ in. Height of stem $3\frac{1}{4}$ in. Date 1706.

Hall marks. 1. Court-hand L. 2. Lion's head erased. 3. Britannia. 4. R is perhaps the first letter, the second one is not legible.

This cup has a straight-sided bowl and thick stem with a small round moulding for a knob.

(b)

SILVER FLAGON. Weight 38.4 oz. Height $11\frac{1}{2}$ in. Diam. of top $3\frac{3}{8}$ in.; of foot 7 in. Date 1746.

Hall marks. 1. Small Roman L. 2. Lion passant. 3. Leopard's head crowned. 4. T. W.

In shape, this is a straight-sided flagon narrowing towards the top. There is the sacred monogram in front, with cross above and three nails below, within a circle of glory: and this inscription "*The gift of Mrs. Cath. Parker, to Prestwold Church, in Leicestershire, 1747.*"

(c)

SILVER DISH. Weight 17 oz. Diam. 10 in. Date 1747.

Hall marks. 1. Small Roman M. 2. Leopard's head crowned. 3. Lion passant. 4. W. G., script letters in a shaped oblong: the mark of *William Grundy*.

In the centre of this plain dish is the sacred monogram, with cross above and three nails below, within a circle of glory, and underneath is "*The gift of Joseph Kirke, Esq., to the parish of Prestwold, Leicestershire.*"

(d)

SILVER PATEN with foot. Weight 15.7 oz. Diam. 8 in. Diam. of foot $4\frac{3}{8}$ in. Height of foot $1\frac{5}{8}$ in. Date 1836.

London hall marks.

This is a plain paten thus inscribed: "*The gift of the Rev. Augustus Packe, to the parish of Prestwold, Leicestershire, 1837.*"

The three oldest pieces make up the communion service recorded in Archdeacon **Bickham's** inventory of 1777.

(a)

The principal inhabitant here in 1706 was **Clifton Packe**, Esq., of Prestwold, who was high sheriff of the county in 1707, and died intestate on 9th June in that year aged 33: he was the grandson of **Christopher Packe**, Lord Mayor.

(b)

The silver flagon must have been given by **Mrs. Parker** only a very short time before her death which occurred on the 2nd July, 1747.*

She was connected with this parish through her mother, **Anne**, who was the eldest daughter of **Christopher Packe**, Lord Mayor of London, towards the repair of whose monument in this church, his granddaughter, **Mrs. Parker**, left £10, legacies were also left by

* See East Norton, p. 252.

her to her first cousin, **Charles Packe**, Esq., and **Penelope**, his wife; he being a younger brother of **Clifton Packe**.

(c)

The gift of the silver dish made by **Joseph Kirke** to this church, bears evidence to the descent of the donor from a family of that name for many years owning land in Burton-on-the-Wolds, a hamlet of this parish. I take him to have been **Joseph**, the son of **Richard Kirke**, fellmonger, of Loughborough, baptized in that parish on 23rd Jan., 1680-1.* He lived in Loughborough following his father's trade, and had one daughter born to him, **Elizabeth**, baptized on 28th March, 1712:* his wife was buried on 13th Sep., 1744;† he himself being buried at Loughborough on 29th March, 1754.*

By his will dated 1745, and proved in Leicester, on 8th April, 1754, **Joseph Kirke**, fellmonger, of Loughborough, left all houses and property in Loughborough bought by his father, **Richard**, and all goods to his daughter, **Elizabeth**, his sole executrix.

The last of this family to own land in Burton-on-the-Wolds, seems to have been **Daniel Kirke**, who died on 30th May, 1746. In his will, dated 19th Feb., 1745, and proved in Leicester, 3rd June, 1746, he left all his houses and lands in Prestwold, Burton, and Hoton, to his kinsman, **Francis**, son of **John Wingfield**, of Loughborough, his sole executor. Arms on the seal to the will: *a chevron between three cross crosslets fitchée*; crest: *a bird*.

(d)

Augustus Packe, the donor of the paten to this church was the fifth and youngest son of **Charles James Packe**, Esq., of Prestwold, by his wife, **Penelope**, the eldest daughter of **Richard Dugdale**, (formerly **Geast**) of Blithe Hall, co. Warwick, and was born on 8th Oct., 1805. He graduated from Christ College, Cambridge, taking his B.A. in 1827, and M.A. in 1830. Soon after the latter date Mr. **Packe** was appointed to the cure of souls in this parish, retaining that position until 1837, the year in which he presented the paten; when he resigned this charge and became curate to the parish of Walton-le-Wolds. He was appointed rector of Walton in 1847, and held the living till the day of his death, 1st Feb., 1861. During his incumbency he rebuilt the chancel of Walton church. Mr. **Packe** married at Albourne, Sussex, on 1st Nov., 1843,‡ **Frances Henrietta**, youngest daughter of **William John Campion**, Esq., of Danny, co. Sussex, by his wife, **Jane**, eldest daughter of **Francis Motley Austen**, Esq., of Kippington, Kent, and left by her an only daughter, **Georgina Frances Packe**, now of Asherne, Dartmouth. Mrs. **Packe** died on 15th Feb., 1878, aged 68, and was buried with her husband at Walton-le-Wolds.

On the South side of the chancel of Walton church is a painted window of two lights to the memory of the Rev. **Augustus Packe**, and on the North side is one to the memory of his wife, a short inscription on a brass plate being placed under each.

* Parish Register.

† Ibid. No name given.

‡ Parish Register.

HOTON.

SILVER CUP. Weight 12 oz. Height $8\frac{3}{8}$ in. Diam. of the bowl $3\frac{1}{4}$ in. Diam. of the foot $3\frac{3}{8}$ in. Height of stem 5 in. Date 1836.

London hall marks.

This cup has a straight-sided bowl and baluster stem; on the former is the sacred monogram.

SILVER PATEN with a foot. Weight 11.8 oz. Diam. 7 in. Diam. of foot $4\frac{1}{4}$ in. Height of foot $1\frac{5}{8}$ in. Date 1836.

London hall marks.

This is a plain paten with the sacred monogram in the centre.

SILVER ALMS DISH. Weight 20 oz. Diam. $10\frac{1}{2}$ in. Date 1837.

London hall marks.

This is a plain dish with the sacred monogram in the centre.

SILVER FLAGON. Weight 36.9 oz. Height $10\frac{3}{4}$ in. Diam. at top $3\frac{3}{4}$ in. at foot 5 in. Date 1827.

London hall marks.

This flagon is straight-sided in shape, narrowing towards the top; with a round top to its lid. It has the sacred monogram in front, and near the foot this inscription; "*This communion plate was presented by Charles William Packe, Esq., to Hoton Church on its being opened for regular Divine Service, Oct. 15th, 1837.*"

PEWTER FLAGON. Height 10 in. Diam. at top $3\frac{3}{4}$ in.; at foot $4\frac{5}{8}$ in. No marks.

This is a straight-sided flagon, narrowing a little towards the top. The lid has a round top and a knob.

This pewter flagon is said to belong to Hoton and not to Prestwold. It is in that case the only piece now remaining of some former communion service belonging to this parish, of which nothing further than this flagon is now known. Until the church was rebuilt, divine service was celebrated here only once a year, viz., on the first Sunday after Easter.

The donor of the silver service now in use here was the representative and direct descendant of **Christopher Packe**, Lord Mayor of London, who took a distinguished part in the affairs of the Commonwealth, and bought the Lordships of Prestwold and Cotes from Sir **Henry Skipwith**, Bart., shortly before 1653.* His descendant, Mr. **Charles William Packe**, was the eldest son of **Charles James Packe**, Esq., of Prestwold, by his wife **Penelope**, eldest daughter of **Richard Geast** (afterwards **Dugdale**) of Blithe Hall, co. Warwick, and was born at Carby, co. Lincoln on 23rd Sep., 1792. Upon the death of his father on 1st March, 1837, he inherited the

* For pedigree of Packe, see *Nichols*, Vol. iii., p. 362, and *Blow's Rutland*, p. 109.

family estates at Prestwold and Hoton. Mr. **Packe** was held in much esteem both on account of his kindly, generous disposition, and for his capability as a man of business. In 1836 he was elected M.P. for South Leicestershire, having been appointed Chairman of Quarter Sessions two years before; both offices were held by him till his death, which took place in Richmond Terrace, London, on 27th Oct., 1867. He was buried in the mausoleum on his estate of Branksom Tower, Bournemouth. Mr. **C. W. Packe** married on 13th Nov., 1822, **Kitty Jenkyn**, the only daughter of **Thomas Hort**, Esq., by **Anne**, his wife. Mrs. **Packe**, who assumed the name and arms of **Reading** upon succeeding to a fortune bequeathed to her by her god-father, **Jenkyn Reading**, Esq., of Harpenden, Herts, died on 22nd Jan., 1870, and was buried at Branksom.

Mr. **C. W. Packe** dying without issue, the Prestwold and Hoton estates passed to his brother, **George Hussey Packe**, of Caythorpe, co. Lincoln, the father of **Hussey Packe**, Esq., J.P., D.L., the present owner of Prestwold and Caythorpe.* Branksom Tower, built by Mr. **C. W. Packe**, and also the estates bought by him in Stretton and Glenn, co. Leicester were inherited, after the death of Mrs. **Packe Reading**, by his nephew **Charles Packe**, Esq., of Great Stretton Hall.

The arms of **Packe** are: *Quarterly, Sable and Or, in the first quarter a cinquefoil Argent with an Ermine spot on each leaf. Crest: A lion's head Or, collared Sable, on the collar three cinquefoils Argent with an Ermine spot on each leaf.*

RAGDALE.

SILVER CUP. Weight 6.3 oz. Height $3\frac{7}{8}$ in. Diam. at top $3\frac{1}{2}$ in.; at foot $2\frac{5}{8}$ in. Date 1758. (PLATE 21.)

Hall marks. 1. Capital old English C in plain shield. 2. Leopard's head crowned, in plain shield. 3. Lion passant in oblong. 4. F. W. script letters in an oblong: the mark of *Fuller White*.

This cup is in shape simply a straight-sided beaker, widening out a little towards the mouth. There is a small plain moulding round the base, which is the only attempt at ornament. It has probably been originally a secular cup.

SILVER PATEN. Weight 7 oz. Diam. $6\frac{1}{2}$ in. Date 1740.

Hall marks. 1. Small Roman E. 2. Leopard's head crowned, each of these first two marks being in a shaped shield. 3. Lion passant in a shaped oblong. 4. An ewer with "I" on one side of it, and an illegible letter on the other, probably a T, which completes the mark of *John Tuite*.

This paten originally a secular piece of plate, a salver, has a raised moulding round its edge and stands on three feet.

* Formerly the property of the Husseys, Barts. Charlotte, daughter of Sir Edward Hussey, 3rd Bart., married Tho. Pochin, of Barkby (p. 256), whose daughter Charlotte Pochin, married C. J. Packe, and eventually inherited the Hussey property.

PEWTER DISH. Diam. 9 in.

Marks. 1. X crowned. 2. Horse's jamb rising from a crown. 3. London. 4. Four small marks, each in a plain shield. (a) S. D. (b) Lion's head erased. (c) Horse's jamb. (d) Per chevron engrailed three leopards' faces.

The cup and paten were probably the gift from his own plate chest, of **Robert Shirley**, 7th Earl **Ferrers**,* who in 1787, the year in which he succeeded to the title, repaired the interior of this church, rebuilding the chancel and porch.† He had two years before built the new Hall, having acquired, by an agreement with his father, this estate. Ragdale church was again repaired in 1875, by the present owner of this ancient inheritance of the **Shirleys**, the Duchess **Sforza**.

RATCLIFFE-ON-THE-WREAKE.

SILVER PATEN. Weight 1.8 oz. Diam. $5\frac{1}{4}$ in. Date *circa* 1500. (FIG. 35.)

No marks.

This is a pre-reformation paten, having a flat edge $\frac{7}{8}$ of an inch wide, the middle part within being sunk in a shallow round. In the centre within a circle is the sacred monogram, the background being covered with zigzag lines; the whole device is gilt. There is also a gilt band round the edge, and there are traces of a former gilt band round the edge at the back. A couple of rudely drawn lines run round the edge of the paten on the top.

SILVER CUP. Weight 5.6 oz. Height $5\frac{5}{8}$ in. Diam. of the bowl $3\frac{1}{2}$ in.; of the foot $3\frac{1}{4}$ in. Height of stem $2\frac{3}{8}$ in. Date *circa* 1571. (PLATE 20.)

No hall marks.

This cup has a bowl shaped into an inverted truncated cone, rounded off at the base: running round it near the top is a band of stroke ornament, divided into six parts by hour-glass curves. Under the bowl is a neck, round which is a reed ornament between a few rule lines; below is a disk divided into eighteen parts by radii; this rests on the usual stem and foot. This cup is very similar to one described by the Archdeacon of **Worcester**.‡

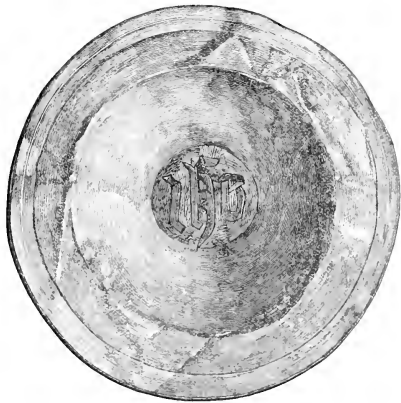

Fig. 35. Circa 1500. $\frac{3}{4}$ of full size. F. H. M. del.

* Page 298. † See *Nichols*, Vol. iii., p. 387. ‡ *Church Plate in the Archdeaconry of Worcester*, 1884. Plate 1

SILVER CUP. Weight 10.2 oz. Height $6\frac{3}{4}$ in. Diam. of the bowl 4 in.; of the foot $3\frac{1}{2}$ in. Height of stem $2\frac{3}{8}$ in. Date **1810**.

London hall marks.

The upper part of the bowl of this cup is straight-sided and concave, the lower part is rounded off and fluted; on the side is engraved the sacred monogram within a circle of glory. The stem is round and narrow, swelling out towards the bowl, and into a flat foot. Round the top of the stem and foot is a gadrooned edge. On the foot is "*To the Church of Ratcliff-on-the-Wreake. The Gift of Earl Ferrers.*"

SILVER PLATE. Weight 14.6 oz. Diam. $9\frac{1}{8}$ in. Date **1808**.

London hall marks.

This plate has in its centre the sacred monogram within a circle of glory, and round its edge the same inscription as that on the last cup.

PEWTER FLAGON. Height 7 in. Diam. at the top $4\frac{3}{8}$ in.; at the foot 5 in. Date **1698**. (PLATE 23.)

Marks. 1. On the bottom inside within a lozenge I. T., a star of six points between the letters, "16" above, "98" below. 2. On the drum W. R., a sword between the letters in a shaped stamp. 3. X crowned. 4. In four small shapes; (a) Lion passant. (b) Golden fleece. (c) Fleur-de-lis. (d) Illegible mark.

This is a solid straight-sided tankard, narrowing a little towards the top. It has a round top to its lid, and the usual handle.

TWO PEWTER PLATES. Diam. of each $8\frac{1}{2}$ in.

Marks. 1. X crowned. 2. Out of a ducal crown a dexter arm embowed, vambraced, holding a spear, in an ornamental shape. 3. "London" in an oblong. 4. In four small shapes; (a) S. H. (b) Fleur-de-lis. (c) Arm as before on a wreath. (d) Per chevron engrailed, three leopards' faces.

The donor of the two modern pieces of plate was **Robert**, 7th Earl **Ferrers**, F.S.A., who was the eldest son of **Robert**, 6th Earl, by **Catherine**, daughter of **Rowland Cotton**, Esq., of Etwall, co. Derby, and was born on 21st Sep., 1756. The Earl, who was the direct representative of Sir **Robert Shirley**, Bart., of Staunton Harold,* succeeded his father in the title and estates in 1787, the latter including the principal part of this parish. In addition to this gift of plate, Earl **Ferrers** presented this church with a clock, and also contributed largely towards the repair of the body of the church and its spire. He took no part in public affairs, "but was very expert and attentive to his private concerns; he was his own manager, and in consequence his fortune prospered."† As an antiquarian he rendered Mr. **Nichols** considerable assistance in compiling the West Goscote portion of his history of this county. Earl **Ferrers** died at Hastings on 2nd May, 1827.

He was twice married; first on 13th March, 1778, to **Elizabeth**, daughter of **John Prentise**, Esq., by whom he had one only son, **Robert Sewallis**, Viscount **Tamworth**, who married the only daughter of the 2nd Lord **Scarsdale**, but died without legitimate issue

* Page 13. † *Gent. Mag.*, Vol. xcvi., pt. 1., p. 561. *Stemmata Shirleiana*, p. 201.

on 6th June, 1824. Lady **Ferrers** dying on 14th Sep., 1799, the Earl married secondly, on that day fortnight, **Elizabeth**, youngest daughter of **Wrightson Mundy**, Esq., of Markeaton, co. Derby, which lady died s.p. on 22nd Feb., 1827. Earl **Ferrers** was succeeded by his brother, **Washington**, 8th Earl, great-grandfather of the present representative of this ancient family. He bequeathed his estates in this parish and in Ragdale, to **Caroline**, daughter of his son, **Robert Sewallis**, Viscount **Tamworth**, which lady married on 17th Sep., 1837, the Duke **Sforza Cesarini**.

REARSBY.

SILVER CUP. Weight 5.6 oz. Height 6½ in. Diam. of bowl 3¾ in.; of foot 3 in. Height of stem 2¾ in. Date *circa* 1575.

Mark. A rose.

This cup, like others of this series, has a bowl shaped into an inverted truncated cone, with concave sides, and a flat projecting base lately renewed, with a few lines running round it. Round the bowl near the lip is a band of Elizabethan foliage divided into four parts by hour-glass curves twice twisted. The stem is evenly balanced, being divided in half by a small round moulding between two lines for a knob, from whence it swells out a little at both ends into a vertical edge, ornamented with a narrow reed moulding. The foot is rounded off into a narrow, vertical, and flat edge, reeds running round the former.

SILVER PLATED PATEN. Diam. 8 in.

This is a plain modern paten.

PEWTER FLAGON. Height 10½ in. Diam. at the top 4¼ in.; at the foot 6⅝ in.

Marks. 1. Inside on the bottom, perhaps a small anchor in a circle. 2. On the lid, sun in splendour repeated four times. 3. On back of purchase P. K. 4. On back of handle O. F. R.

This is a straight-sided flagon, narrowing a little towards the top. It has a flat top to its lid, and a wide foot.

PEWTER PLATE. Diam. 9⅞ in.

Marks. 1. X crowned. 2. Eagle displayed, surrounded by an illegible name. 3. Rose crowned. 4. C. I. A. 5. In four plain shields, (a) A lion rampant between four pellets, a fleur-de-lis below. (b) Fleur-de-lis. (c) Leopard's face. (d) I. G., a fleur-de-lis between two pellets below.

PEWTER PLATE. Diam. 8⅞ in.

Marks. 1. "From London" on a scroll. 2. Lion rampant, in an ornamental oblong. "W. Cooke" above.

SAXELBYE.

SILVER CUP. Weight 8.1 oz. Height 6⅝ in. Diam. of the bowl and of the foot 3¾ in. Height of stem 2½ in. Date 1639. (PLATE 23.)

Hall marks. 1. Court-band B in a plain shield. 2. Leopard's head crowned. 3. Lion passant, each within an outer-shaped line. 4. W. I., two annulets above, in a square.

The bowl of this cup is straight-sided in the lower part with a flat base, swelling out above into a bell-shaped lip. The stem is thick, having a large round knob in its upper part, from whence it swells out into a plain flat foot under which is the lion passant. The stem and foot are made out of one piece of metal.

SILVER PATEN with a foot. Weight 2.9 oz. Diam. $4\frac{7}{8}$ in. Diam. of foot $1\frac{3}{4}$ in. Height of foot $\frac{7}{8}$ in. Date 1639. (PLATE 23.)

Hall marks as on the cup.

This paten which fits on to the cup with its foot downwards, has a flat edge from which the middle part is sunk flat. The foot is a disk attached to the paten by a stem which swells out at each end.

PEWTER PLATE. Diam. $9\frac{3}{4}$ in.

Marks. 1. On edge, R. K. 2. Capital Roman L crowned in a shaped shield, repeated four times. 3. Underneath, Prince of Wales' feathers rising out of a crown within a circle.

This plate, evidently made for a paten, has a flat edge $2\frac{1}{4}$ inches wide, from which the middle part is sunk flat $\frac{1}{4}$ in. deep.

PEWTER BASIN. Diam. $9\frac{5}{8}$ in. Height $4\frac{1}{4}$ in.

Mark. X crowned.

This is a plain basin standing on a round foot.

The lord of the manor of Saxelbye in 1639 was Sir **Francis Englefield**, Bart., who had married **Winifred**, eldest daughter and co-heir of **William Brokesby**, of Shouldby.

SEAGRAVE.

SILVER CUP. Weight 6.1 oz. Height $6\frac{1}{2}$ in. Diam. of bowl $3\frac{1}{2}$ in.; of the foot $3\frac{3}{8}$ in. Height of stem $3\frac{1}{8}$ in. Date *circa* 1635. (PLATE 21.)

No hall marks.

This cup has a bowl with a flat base, straight-sided in the lower part, swelling out higher up into a bell-shaped lip. The stem is evenly balanced, divided by a large round knob, from whence it swells out toward both ends into plain vertical edges. The foot, which is rounded, has underneath it "**Thomas Hudson + John Blounte**," the names probably of the churchwardens.

PEWTER PATEN with foot. Diam. $7\frac{3}{4}$ in. Diam. of foot $3\frac{3}{4}$ in. Height of foot $1\frac{3}{4}$ in.

The only mark on this paten is H. M. underneath.

PEWTER DISH. Diam. $9\frac{1}{4}$ in.

Marks. 1. X crowned. 2. "London." 3. Eagle displayed with "**Thomas**" above, "**Hodgkin**" below.

PEWTER BASIN. Diam. $7\frac{7}{8}$ in. Depth $1\frac{1}{8}$ in.

Marks. London, with some illegible mark above.

This basin was, until recently, used for collecting the offertory.

PEWTER FLAGON. Height $10\frac{3}{4}$ in. Diam. at top $3\frac{3}{4}$ in.; at foot $5\frac{1}{8}$ in.

No marks.

In shape this flagon is straight-sided, narrowing towards the top. It has a flat lid with a knob.

SILEBY.

SILVER CUP. Weight 5.9 oz. Height 6 in. Diam. of the bowl $3\frac{1}{2}$ in.; of the foot $2\frac{3}{4}$ in. Height of stem $2\frac{1}{4}$ in. Date *circa* 1570. (PLATE 19.)

Mark. Leopard's face in same shaped outline.

This little cup, like others by the same maker,* has a deep narrow bowl, shaped into an inverted truncated cone, with a bell-shaped lip, standing on a short straight stem, swelling out a little at each end. The foot is of the usual shape, with the egg and tongue ornament round its edge.

SILVER CUP. Weight 19 oz. Height 9 in. Diam. of the bowl $4\frac{1}{4}$ in. ; of the foot $4\frac{1}{2}$ in. Height of stem $3\frac{1}{4}$ in. Date 1639. (PLATE 23.)

Hall marks. 1. Court hand B in a plain shield. 2. Lion passant. 3. Leopard's head crowned, each within an outer shaped line. 4. I. M., a pig passant below, in a plain shield.

This large cup has a straight-sided bowl with a flat base and a bell-shaped lip. The stem is evenly balanced, being divided in half by a large round knob, from whence it swells out to the bowl, and into a plain foot, which is rounded off into a bevelled edge. Round the bowl is "*The Gift of William Lane, Citizen and Marchant Taylor of London, Deceased, To the Parish Church of Sileby, December the first, Anno Domini, 1639.*"

SILVER PATEN with a foot. Weight 7.2 oz. Diam. $6\frac{1}{4}$ in. Diam. of the foot $2\frac{7}{8}$ in. Height of foot $\frac{3}{4}$ in. Date 1639. (PLATE 23.)

Hall marks as on the last cup.

This paten, which fits on to the cup with the foot downwards, has a wide flat edge, from which the middle part is sunk flat. The foot is a disk attached to the paten by a stem swelling out at both ends. Underneath the paten is the same inscription as that on the cup.

SILVER PLATED PATEN. Diam. $5\frac{1}{4}$ in.

This is a small plain modern paten made to fit on to the oldest cup.

GLASS FLAGON WITH SILVER PLATED FITTINGS. Height $11\frac{1}{2}$ in.

TWO PEWTER FLAGONS. Height of each $11\frac{1}{2}$ in. Diam. at the top $4\frac{7}{8}$ in. ; at the foot $6\frac{1}{4}$ in.

Marks. 1. On the lid: small seeded rose within a shaped stamp, repeated four times. 2. On the bottom inside: A. S., a star of six points above, within a lozenge.

These are large, plain, conical-shaped flagons, narrowing from the feet. They have each a large handle and purchase, and a flat top to the lid.

PEWTER BASIN. Diam. $8\frac{1}{2}$ in. Depth 1 in.

Marks. 1. On the upper surface in four pointed shields: (a) R. R. with a mullet below. (b) An anchor. (c) A buckle. (d) Lion rampant. 2. On the back: Prince of Wales' feathers rising out of a ducal crown between R. E., within a dotted circle. 3. "London" in an oblong.

This is a plain shaped alms basin.

In the terrier of 1709 the silver vessels here are mentioned, but not the pewter.

The larger silver cup with the paten, were bought in accordance with this clause in **William Lane's** will, made 1st July, 1639, and proved P.C.C. 17th July, 1639; "*I give and bequeath to the use of the church of the said town of Sileby, one silver chalice or communion cup of the value of £5, and also £2 10s. for a plate to lay the bread upon at the communion, with my name engraved thereon, and a case to put the same in.*" **William Lane** was born in this parish, and was probably the son of **William Lane**, a farmer of this place, members of

* Plate xviii.

whose family remained settled here for several years after that date.* When young he was sent to London, and brought up to the trade of a tailor. He afterwards set up in business for himself, and prospered in his trade as is evidenced in his will.† **William Lane** died in his house in Grub Street, and was buried in St. Giles', Cripplegate, on 16th July, 1639.‡

In addition to the above bequest, **William Lane**, "the elder," left to the minister, wardens, and overseers of Sibley, ("where I was born,") £100 to buy land producing £6 a year; £1 of which he devoted to the minister of Sibley for preaching one sermon on the day of his funeral, and another six months after in each year; the remaining £5 to be ordered to be given to poor men of that parish on the same days. He left to the poor of St. Giles', without, Cripplegate, ("where now I am a parishioner,") £4 for bread. To the sixteen men of the Company of Merchant Taylors £5 for a supper on the day of his burial. To his grandson **Robert Barnard**,§ his house in Grub Street. To **Grace**, daughter of his son, **William Lane**,|| his lands in co. Essex. Legacies to several friends. His son, **William Lane**, sole executor.

A case to hold the cup and paten was procured as Mr. Lane desired, but this is now no longer here. His bequest of £100 is now represented by 16 acres 1 rood 34 poles of land in Barrow, and 2 acres 1 rood in Charnwood Forest.

SYSTON.

SILVER PATEN. Weight 2.7 oz. Diam. $4\frac{1}{2}$ in. Date circa 1500. (FIG. 36.)

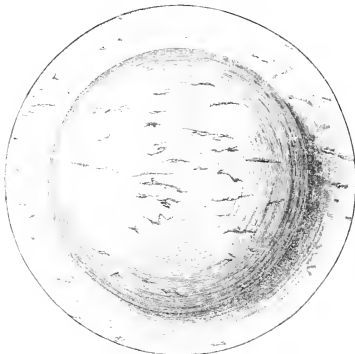

Fig. 36. Circa 1500. $\frac{2}{3}$ of full size. F. H. M. del.

No marks.

This is a pre-reformation paten of the simplest possible description. It has a flat edge $\frac{2}{3}$ of an inch wide, the middle part being sunk in a shallow round. The centre point is still to be seen in the middle. On the back are to be seen small rough open spaces owing to the metal not having been beaten close enough. Traces of former gilding appear to be on upper surface. Underneath is this inscription; "*Original date unknown, A.D., 1881;*" which was placed there when the paten had a few dints taken out of it. The metal is thick throughout, especially in the middle.

* "Tho. Lane, the son of William, baptized 5th Aug., 1571;" parish register, which begins too late to record the bap. of William. † Several of his name appear in the books of the Merchant Taylors' Co.; the list of apprenticeships do not begin till 1583. On 10th May, 1588, William Lane, who had been apprenticed to Evan Thomas, received the freedom of the Company. ‡ Parish Register. § The husband, I imagine, of his granddaughter. "Robert Barnard, gent., 26, of St. Andrew's, Holborn, bach., and Elizabeth Lane, of St. Leonard's, Foster Lane, spinster, 16, dau. of Will. Lane, of same, Merchant Tailor; at All Hallows in the Wall." Licence 3rd Nov., 1634. || "William Lane, of city of London, Merchant Tailor, and Ellen Daye, spinster, dau. of John Daye, of Chard, gent.; at St. Leonard's, Shoreditch." Licence 20th April, 1618. *Publica. of Harl. Soc.* Vol. xxvi., pp. 219 and 59.

SILVER CUP. Weight 6.5 oz. Height 6 $\frac{3}{8}$ in. Diam. of the bowl 4 in.; of the foot 3 $\frac{1}{2}$ in. Height of stem 3 in. Date *circa* 1575. (PLATE 20.)

One mark only; a rose.

This cup is just like others of this series in having a bowl shaped into an inverted truncated cone with concave sides, and a flat projecting base, divided in half by a small knob, and a foot of the usual shape. It differs from others in having round its bowl an exceptionally wide and beautiful band of Elizabethan foliage. Under the foot is "A.D., 1570, 1881:" placed there when the cup had a few repairs made in it.

TWO SILVER CUPS. Weight of each 13.6 oz. Height of each 7 $\frac{7}{8}$ in. Diam. of the bowl 4 $\frac{1}{2}$ in.; of the foot 5 $\frac{1}{8}$ in. Height of stem 5 $\frac{1}{4}$ in. Date 1867.

London hall marks.

These cups have globular-shaped bowls, hexagonal stems and knobs. The foot of each is shaped into six lobes. Round the bowl of each is "*This cup is the New Testament in my Blood;*" and under the foot "*Presented to Syston Parish Church by a few Friends, Xmas, 1867.*"

SILVER PATEN. Weight 4.8 oz. Diam. 6 in. Date 1867.

London hall marks.

Round the flat edge of this paten is; "*The Body of our Lord Jesus Christ which was given for thee.*" The middle is sunk in a six-lobed depression; in the centre is the sacred monogram within an ornamental circle. Underneath the paten is the same inscription as that on the two cups.

SILVER PLATED FLAGON. Height 10 in. Diam. at the top 1 $\frac{3}{4}$ in.; at the foot 3 $\frac{1}{2}$ in.

This is a jug-shaped flagon, with a conical lid surmounted by a cross. Round the edge of the foot is; "*Presented by the Choir, 1874.*"

GLASS CRUET WITH SILVER PLATED STOPPER. Height 10 $\frac{1}{4}$ in.

TWO PEWTER PLATES. Diam. 8 $\frac{3}{4}$ in.

Marks. 1. On the edge: "The Parish of Syson." 2. On the back: X crowned. 3. "Superfine hard metal" on a scroll. 4. In four small shapes: (a) Lion's head erased. (b) Leopard's head crowned. (c) Lion passant. (d) W. C., a pellet between the letters.

It is pleasing to be able to relate that the above mentioned ancient paten and cup still belong to Syston church; in spite of their having recently passed through considerable risk of being parted from the church to which they have belonged for so many years. At the time when the modern silver pieces were bought by a few friends of the parish in 1867, the old paten and cup were presented by the then vicar* and churchwardens to Mr. H. W. Needham, of Syston, who was one of the principal subscribers to the modern vessels. In the possession of this gentleman they remained until the year 1881, when he very kindly placed them in the hands of the late vicar, the Rev. W. M. Croome,† in order that they might be sold and the proceeds given towards the cost of the large additions which were then being made in the church. Fortunately the late Mr. F. J. Morrell, heard of the proposed sale, bought the paten and cup for £10, and generously gave them back again to Syston church, paying for the cost of some small repairs made in them at the same time.

* The Rev. E. Morgan.

† Now Rector of Islip, Northants.

Mr. **Frederick Joseph Morrell**, the rescuer of the two ancient pieces, was the third son of **Baker Morrell**, Esq., of Oxford, by **Mary Elizabeth**, daughter and co-heir of the Rev. **Joseph Chapman**, D.D., president of Trin. Coll., Oxford, and was born on 25th Jan., 1811.* Mr. **F. J. Morrell**, who resided first at Black Hall, Oxford, and afterwards at his seat, Broughton Grange, near Banbury, was for many years solicitor to the University of Oxford. During the long time that he held that important post, he was held in great esteem by the members of the University, in the affairs of which he at all times took the keenest interest. He died on 13th Jan., 1883. Mr. **F. J. Morrell** married on 23rd Dec., 1834, **Elizabeth Maria**, daughter of **Joseph Parker**, Esq., of Black Hall, Oxford, by whom he had five sons and four daughters, the youngest of whom is the wife of the Rev. **W. M. Croome**.

THRUSSINGTON.

SILVER CUP. Weight 8.4 oz. Height 6 in. Diam. of the bowl $3\frac{5}{8}$ in.; of the foot $3\frac{1}{2}$ in. Height of stem $2\frac{1}{2}$ in. Date 1714.

Hall marks. 1. Court-hand T. 2. Britannia. 3. Lion's head erased. 4. P. E., a mullet above in a shaped shield; the mark of *Edmund Pearce*.

This cup has a bowl shaped into an inverted truncated cone, with a lip slightly bell-shaped, and a flat projecting base with lines running round its edge. Its stem is evenly balanced, being divided in half by a knob formed with a small round moulding on a fillet, from whence it swells out to the bowl, and into the foot which is flat at the top, mouldings running round its edge. Round the bowl is; "*Benjamin Storer, Willuam Fernley, Churchwardens, 1714.*" This cup was plainly made after the pattern of an Elizabethan cup, which, probably owing to its being out of repair, was replaced by the present one in 1714. It is not unlikely but what the metal as well as the shape of the old cup has been preserved in the new one.

SILVER CUP. Weight 9.4 oz. Height $6\frac{3}{4}$ in. Diam. of the bowl $4\frac{1}{4}$ in.; of the foot $3\frac{1}{2}$ in. Height of the stem $2\frac{3}{4}$ in. Date 1808.

London hall marks.

This is a secular-shaped cup, having a bowl straight-sided and concave in its upper part, rounded off and fluted below, a small moulding running round its lip. The stem, which is topped by a disk with a gadrooned edge, is round and narrow, swelling out into a flat foot. On one side of the bowl is the sacred monogram, with a cross and three nails within a circle of glory, chaste; on the other side is; "*The gift of the Rev^d. Edw^d. Henry Hoare, Vicar, to the Parish of Thrussington, Leicestershire, A.D. 1834.*"

SILVER PATEN with a foot. Weight 4.5 oz. Diam. $5\frac{1}{2}$ in. Diam. of the foot $2\frac{1}{2}$ in. Height of foot $1\frac{1}{2}$ in. Date 1721.

Hall marks. 1. Capital Roman F in a plain shield. 2. Leopard's head crowned in a circle. 3. Lion passant in a plain oblong. 4. L., partly obliterated.

* See *Burke's Landed Gentry*.

This paten, which must formerly have belonged to some other church, is flat, with a small moulding running round its edge. Its foot is a hollow drum, ending in a round moulding and flat edge. In the centre is engraved the sacred monogram, with a cross and three nails in a circle of glory, round which is the same inscription as that on the last cup.

SILVER PLATE. Weight 13.7 oz. Diam. $9\frac{1}{2}$ in. Date 1808.

London hall marks.

This is a plain basin-shaped dish with a flat edge. In the centre is the sacred monogram, chased, and round the edge is the same inscription as that on the second cup.

PEWTER FLAGON. Height $13\frac{1}{4}$ in. Diam. at the top $4\frac{5}{8}$ in.; at the foot $5\frac{1}{2}$ in.

No marks.

This is a thickly made straight-sided flagon, narrowing towards the top, which projects into a round moulding. Its lid has a round top surmounted with a knob.

PEWTER PLATE. Diam. $9\frac{1}{4}$ in.

Marks. 1. On the edge in four small shapes; (a) Lion passant. (b) Leopard's head crowned. (c) Three fleur-de-lis. (d) I. D. 2. Underneath, a rose crowned, with perhaps "London" above. 3. Indistinct mark.

This is a plain rough plate with a flat edge. It was formerly used as a paten.

PEWTER PLATE. Diam. $9\frac{1}{8}$ in.

Marks. 1. Eagle displayed, "Thomas" above, "Hodgkin" below. 2. O. T., each letter being crowned. 3. "London" in a shaped oblong.

This is a plain basin-shaped plate with a flat edge.

Benjamin Storer, the first churchwarden named on the oldest cup, was the son of **Thomas Storer**, of this parish, and died on 9th March, 1740, aged 58, leaving by his wife **Mary Ayres**, two sons, **Thomas** and **William**, who, together with their father, are buried in this church.

William Fernley, the second churchwarden, was a member of a family whose name, often spelt **Fernlaw**, appears in the register in 1691, and in many succeeding years down to the end of the last century. This warden was either **William Fernley**, ropemaker, who by his wife, **Ruth**, had several children, and who died in 1715; or else **William Fernley**, married to **Anne**, who died in 1719, being entered in the register as a yeoman.

The Rev. **Edward Henry Hoare**, the donor of the three modern pieces, was the only son of **Edward Hoare**, Esq., of the Royal Crescent, Bath, a descendant of Major **Hoare**, who settled in co. Cork in 1649, by his wife, **Elizabeth**, sister and co-heiress of **John Hatch**, Esq., M.P., and was born on 1st Oct., 1760. He took his M.A. degree from Trinity Coll., Dublin, and was at one time curate of Coddington, co. Notts. He was afterwards appointed to the rectory of Thrussington, which he held till his death on 2nd March, 1843, at his eldest son's house, Barkby vicarage. The Rev. **E. H. Hoare**, was twice married: first, to **Elizabeth**, daughter of the Rev. **Thomas Davenport**, rector of Widmerpool, Notts, which lady bore her husband three sons and one daughter: secondly, to his cousin, **Lucinda Rose**, daughter of the Rev. **Deane Hoare**, M.A., Vicar-General of Limerick Diocese.

WALTON-LE-WOLDS.

SILVER CUP WITH COVER PATEN. Weight of cup 4.3 oz. Height $5\frac{1}{2}$ in. Diam. of bowl and of foot $3\frac{1}{2}$ in. Height of stem $2\frac{3}{8}$ in. Date *circa* 1570. (PLATE 21.)

Mark. Maiden's head coupé at shoulders? between N. G.

This cup, one at Goadby (p. 231), and another at Wyfordby (p. 147), were made by the same maker who seems to have failed in each case to stamp his mark correctly. On this one the letters are upright but the mark between is all out of shape. This cup differs from the other two in being unusually dumpy in shape. It has a straight-sided flat based bowl, swelling out into a bell-shaped lip, and a thick evenly-balanced stem divided in half by a large round knob covered with little vertical strokes. Its foot is rounded into a flat edge. Round the bowl is a band of foliage divided into three parts by wide hour-glass curves.

SILVER COVER PATEN. Weight 1.1 oz. Diam. $3\frac{3}{8}$ in. Date *circa* 1570. (PLATE 21.)

No marks.

Round the top of this cover which is of the usual shape, is a band of foliage like the one round the cup. There is the usual small vertical rim round the inside. The foot which it once had has been accidentally wrenched off, stem and all, apparently many years ago, a piece of the paten being torn off with it. The hole thus made has been filled up with a groat of Queen **Mary**, coined before her marriage with **Phillip**, the reverse of which is shown outside bearing the arms of France and England quarterly and the motto "*Veritas temporis filia*;" only a small portion of the obverse of the coin is seen inside the cover.

SILVER FLAGON. Weight 14.1 oz. Height $10\frac{1}{2}$ in. Diam. at the top 2 in.; at foot $3\frac{1}{2}$ in. Date 1868.

London hall marks.

This is a jug-shaped flagon with the sacred monogram on one side. At intervals four small cable mouldings and bands of foliage run round the middle.

PEWTER FLAGON. Height 11 in. Diam. at top $4\frac{5}{8}$ in.; at foot $6\frac{1}{8}$ in. Date *circa* 1700. (PLATE 23.)

Marks. 1. W. F., with a star above and a pellet below, within a lozenge; stamped on the top of the lid and on the bottom of the flagon, inside. 2. On the lid, four squirrels in as many lozenges.

This is a straight-sided flagon, rather wide in proportion to its height, narrowing very slightly towards the top. All round the drum and on the lid, are engraved, conventionally in dotted lines, flowers and leaves of a large size. At the foot of the drum in front, two large birds are engraved amongst the foliage.

PEWTER DISH. Diam. $9\frac{5}{8}$ in.

Marks. 1. X crowned. 2. A lion holding a crown, with an indistinct name below. 3. "London." 4. S. T. E. 5. Capital old English P. 6. Britannia. 7. Lion's head erased. 8. An indistinct mark.

PEWTER DISH. Diam. $9\frac{1}{8}$ in.

Marks. 1. "London." 2. An eagle displayed with "Thomas" above, and "Hodgkin" below; the end of the latter name being as usual very indistinct.

The silver flagon was given to this church by **Frances Henrietta**, the wife of the Rev. **Augustus Packe**, rector of the parish.*

WYMESWOLD.

SILVER CUP. Weight 9.1 oz. Height $3\frac{3}{4}$ in. Diam. of bowl $4\frac{1}{2}$ in.; of foot $3\frac{3}{8}$ in. Height of stem $2\frac{1}{4}$ in. Date 1512. (FIG. 37.)



Fig. 37. 1512. Full size. M. P. del.

Hall marks. 1. Small black-letter P in outline shaped to letter. 2. Leopard's head crowned within a circle. 3. A tun in an oblong.

This pre-reformation cup, the only piece as yet known to be stamped with the hall marks of 1512, is thought to have originally been a ciborium or pix. It is almost exactly like one with a cover, belonging to St. Mary's church, Sandwich,† and closely resembles another made in 1521, owned by Mr. J. Dunn Gardner, and exhibited by him in the South Kensington Museum. This cup has a wide, shallow, straight-sided bowl resting on a conical stem and

* See Prestwold, p. 294. † *Church Plate in Kent*, by Rev. Canon W. A. Scott Robertson, 1886, p. 5

foot. Round the bowl in Tudor letters is "*Soli Deo Honor et Gloria*," engraved perhaps when this piece was first used as a communion cup: the background of the inscription is covered with zigzag lines. Round the top of the stem is a cable moulding, a beaded moulding running round the upper edge of the foot; the lower edge of the latter is turned round upwards. Traces of gilding are to be seen on the engraved band round the bowl, and also on the foot.

SILVER PATEN with foot. Weight 6.5 oz. Diam. 7 in. Diam. of foot $3\frac{1}{8}$ in. Height of foot $1\frac{3}{8}$ in. Date 1704. (PLATE 24.)

Hall marks. 1. Court-hand I. 2. Lion's head erased. 3. Britannia. 4. B. E., with cinquefoil below. Mark probably of *Benjamin Bentley*.

This is a plain salver with gadrooned edges. In the centre, copied from the ancient cup, is "*Soli Deo Honor et Gloria*. *An. Dom. 1705*."

SILVER FLAGON. Weight 31.8 oz. Height $10\frac{1}{2}$ in. Diam. of top $4\frac{5}{8}$ in.; of foot $6\frac{1}{8}$ in. Date 1704. (PLATE 24.)

Hall marks. 1, 2, and 3. As on paten. 4. F.A.; the mark of one of the *Fawdery's*.

This flagon is straight-sided in shape, narrowing a little towards the top. The lid has a high round top, the purchase being bent down over the lid. In the front is "*Honor et Gloria Soli Deo, 1705*."

The following entry in the parish register reveals the donor of the paten and flagon; "1705. *Memorandum. That Dame Katherine Yorke, Relict first of William Leeke, Esq^r. Serjeant-at-law, and then of Sr. William Yorke, of Lessingham, in ye County of Lincoln, Kn^t. did, upon ye 26th day of May, (being Whitsun Eve,) in ye year of our Lord, 1705, give to the use of the Communion of ye Parish Church of Wymeswold, a silver flagon, and a silver salver, inscribed 'Soli Deo Honor & Gloria, 1705.'*"

"*Edward Moises, Vic^r. Tho. Turner, Wm. Burrows, Ch. Wardens.*"

The donor of these pieces was a granddaughter of the donor of the flagon to Lockington,* she being the youngest daughter of **William Bainbrige**, of Lockington, by his third wife, **Mary**, daughter of **German Ireton**, of Attenborough, co. Notts, and was born in 1643. She married firstly at Wymeswold, on 4th Oct., 1670,† **William Leeke**, Esq., serjeant-at-law, who was baptized here, on 29th June, 1630,† being the eldest son of **William Leeke**, a landowner in this parish, by **Katherine**, his wife. Serjeant **Leeke** was a distinguished lawyer, and, if his epitaph speaks the truth, a man of singular modesty, for being made Baron of the Exchequer by King **Charles II.**, he at once resigned that office. He died on 9th Oct., 1687, and was buried in the chancel of this church on the 13th.†

A large white marble monument with an Ionic pillar on either side, was erected to his memory by his widow and daughter on the South side of the chancel. This monument, which blocked up one of the windows, was moved to the West end, under the tower, when this church was restored by the late Dean **Alford**, in 1844. In the upper part of it are these

* Page 21.

† Parish Register.

arms: *Argent on a saltire engrailed Sable, nine annulets Or*; **Leeke**; *impaling, Argent a chevron embattled between three battle axes Sable*; **Bainbrigge**. Within an oval is a long inscription in latin, given in *Nichols*, (Vol. iii., p. 506): in this the sergeant is spoken of as being "*iam principii quam populo charus.*"

His widow, Dame **Katherine**, married again in this church, on 6th May, 1690,* **Sir William Yorke**, Knt., of Leasingham, Lincolnshire, who was the son of **William Yorke**, of Burton Pedwardine, co. Lincoln, by his wife, **Elizabeth Walgrave**, and was knighted on 5th Nov., 1674. **Sir William**, who was M.P. for Boston from 1679 to 1685, from 1688 to 1695, and from 1700 to 1702, had been married before to **Penelope**, daughter of **Richard Samwell**, of Gayton, Northants, and had had by her 6 sons and 2 daughters.

Lady **Yorke**, who survived her second husband, died a few weeks after she had made this gift of church plate, and was buried at Wymeswold on 9th July, 1705.* No monument was placed to her memory. She had one child only, **Catherine Leeke**, who married here on 8th Jan., 1699,† **Thomas**, son and heir of **Rowland Okeover**, Esq., of Okeover, Staffordshire; and bore her husband a son, **Leeke**,† afterwards of Okeover, and two daughters, **Elizabeth**, and **Katherine**.

In her will, made 28th May, and proved in Leicester, on 5th Sep., 1705, "Dame **Katherine Yorke**, of Wymeswold," left to "daughter" **Katherine** for life, $\frac{1}{3}$ part of parsonage of Wymeswold, and $\frac{1}{3}$ part of glebe land and tithe barns, stables, lands, and tenements thereto belonging; after her death said $\frac{1}{3}$ parts to "my grandson" **William Okeover**, and "granddaughters" **Elizabeth** and **Katherine Okeover**: to "my brother and sister-in-law" **Mr. Sudbury** and his wife, 20s. each; to their daughter, **Katherine**, £10, and to their three sons, £5 each: to "my niece," **Katherine Peale**, £10, and her sons £5 each: to **Elizabeth Bainbrigge**, widow of "my late brother," **Henry Bainbrigge**, £10: to "my god-son" **Earle Bainbrigge**, £40: and to rest of children of "my brother," **Henry**, £10 each: to "my grandson," **Leake Okeover**, £20: to "my granddaughter," **Elizabeth Okeover**, £20: to "my granddaughter," **Katherine Okeover**, £20: to **William Cooke**, of Wymeswold, gent., £20: to "my sister-in-law," Mrs. **Barbara Bainbrigge**, and to Mrs. **Mary Bromskel**, £10 each: to "nephew," **William Bainbrigge**, and his wife, and to all his brothers and sisters, to "nephew," **John Bainbrigge**, and his wife, to **Mr. John Hawford**, and **Elizabeth**, his wife, 20s. each: to "my godson," **William**, son of said nephew, **William Bainbrigge**, £5: to "my cousin" **German Ireton**, **Mr. George Fisher**, of Hickinge, and **Mr. George Langford**, of Nottingham, 20s. each: to such children of "my nephew," **Thomas**, son of "my late brother," **Gervas Bainbrigge**, as shall be living at my death, £5 each: to "son-in-law," **Thomas Okeover**, Esq., £50: to "niece," **Anne Orme**, widow, £100: to god-daughter, **Katherine Orme**, £20: to other children of said **Anne Orme**, £5 each: to **Mary Maior**, daughter of **William Maior**, of borough of Leicester, gent., £5: to "sons-in-law," **William Yorke**, Esq.,‡ **Thomas Yorke**, Esq., and their two sisters, Mrs. **Penelope Tompson**, and Mrs. **Philip Preston**, £10 each: to vicar of Wymeswold 40s.: to poor of ditto £10: to educate poor children of ditto £10: all rest of personalty to daughter **Katherine Okeover**, sole executrix.

* Parish Register. † Succeeded by his distant cousin H. F. Okeover; vide *Burke's Landed Gentry*.

‡ **William**, died 2 Jan., 1725; buried at Burton Pedwardine, M.I., the registers of which begin in 1754

GUTHLAXTON. FIRST DEANERY.

AYLESTONE.
BLABY.
COSBY.
COUNTESTHORPE.
CROFT.
DESFORD.

ENDERBY.
GLENFIELD.
BRAUNSTONE.
KIRBY MUXLOE.
NARBOROUGH.
NEWTOWN LINDFORD.

OADBY.
RATBY-CUM-GROBY.
STONEY STANTON.
THURLASTON.
WHETSTONE.
WIGSTON MAGNA.

 AYLESTONE.

SILVER CUP. Weight 9 oz. Height $7\frac{3}{8}$ in. Diam. of the bowl 4 in.; of the foot $3\frac{7}{8}$ in. Height of the stem $3\frac{1}{8}$ in. Date 1662. (PLATE 24.)

Hall marks. 1. Capital old English E in a plain shield. 2. Lion passant. 3. Leopard's head crowned; each of the two latter have an outside line following its outline. 4. R. P., with a cinquefoil below, in a plain pointed shield.

This cup has a straight-sided bowl with a slightly bell-shaped lip. Its stem is divided by a large round knob, from whence it swells out into the bowl and into the foot; which latter ends in a round moulding and a sloping flat edge.

SILVER PATEN with a foot. Weight 4.3 oz. Diam. $5\frac{1}{4}$ in. Diam. of the foot $2\frac{1}{4}$ in. Height of the foot $\frac{5}{8}$ of an inch. Date 1662. (PLATE 24.)

Hall marks as on the cup.

This paten has a flat edge, the middle part being sunk flat. The foot is a disk attached to the paten by a thick round stem swelling out at both ends. The paten fits on to the cup with the foot downwards.

SILVER DISH with a foot. Weight 11.2 oz. Diam. $7\frac{1}{2}$ in. Diam. of the foot $3\frac{3}{8}$ in. Height of the foot $1\frac{1}{2}$ in. Date 1717.

Hall marks. 1. Capital Roman B in a plain shield. 2. Britannia. 3. Lion's head erased. 4. An anchor between W. A., in a shaped shield; the mark of *Joseph Ward*.

This dish has a flat edge $\frac{3}{8}$ of an inch wide with small raised mouldings running round it; the middle part is sunk flat $\frac{1}{2}$ of an inch in depth. The stem of the foot is at the top $1\frac{1}{2}$ inch thick; from thence it swells out into a plain flat foot, upon which is engraved the sacred monogram with a cross above and three nails below, within a circle of glory. In the centre of this dish is the monogram here given (FIG. 38), the date "1718" below.



Fig. 38.

SILVER DISH with a foot. Weight 11.1 oz.

Exactly like the last.

SILVER FLAGON. Weight 38.9 oz. Height 10 $\frac{3}{4}$ in. Diam. at the top 4 in. ; at the foot 6 $\frac{3}{4}$ in. Date 1717.

Hall marks as on the dishes.

This is a straight-sided flagon narrowing to the top. It has the usual shaped handle, with the maker's mark on the back, and a round top to its lid. In front is the sacred monogram, with a cross and three nails, within a circle of glory: below which is the same cipher and date as that on the two dishes. (FIG. 38.)

PEWTER BASIN. Diam. 8 $\frac{1}{4}$ in. Height 2 in.

Marks. 1. A seeded rose crowned, a spray of foliage on either side of it. 2. On a scroll, "London."

This is a plain ordinary-shaped basin.

In 1662, **John**, 8th Earl of **Rutland**, was lord of the manor and chief proprietor of Aylestone.

No record has been found relating to the gift of the two silver dishes and flagon so that our only guide is the monogram, which has been read thus; * "G. A. H.," doubled: which in all probability stand for "**Gustavus** and **Anne Hawes**." The former was admitted to Trinity Coll. Camb. as a subsizar on 20th Feb., 1656,† and took his B.A. from thence in 1661. According to his epitaph Mr. **Hawes**, during the Commonwealth, "Ecclesie Anglicanæ Liturgiæ, haud sine capitis periculo, frequentavit."‡ After the troubles he was private chaplain to **John**, Earl of **Rutland**, who presented him to the living of Croxton Kerrial, from whence he was moved to Redmile, given to him by **John**, 1st Duke of **Rutland**, who in Feb., 1693-4, presented him to the rectory of Aylestone, which he held till his death, without issue, on 20th Feb., 1715-16, aged 76.

The Rev. **Gustavus Hawes** by his will, made 19th Jan., 1712, and proved in Leicester on 7th March 1715-16, left all lands wheresoever to his wife **Anne** if living, if she predeceases him, such lands to go to niece **Mary**, wife of **Edward Broughton**, Clerk. MS. sermons to be burnt; "such books as by any writing under my hand I shall appoint," to be presented to **John**, Duke of **Rutland**, for his library at Belvoir; all personalty to wife his sole executrix.

Mrs. **Hawes** died on 8th Aug., 1728, aged 71, and was buried next her husband in the chancel of this church.

In her will, dated 14th May, 1716, and proved, with a codicil dated 26th March, 1728, at Leicester on 14th Aug., 1728, **Anne Hawes**, "of Aylestone, widow," made bequests; to her "grand-nephew" **Gustavus**, son and heir of "nephew-in-law" **Edward Broughton**, Clerk; "grand-nephew" **Robert**, son and heir of "nephew" **Christopher Banks**; "niece" **Susannah Pole**: "sisters" **Jane Pole**, **Susanna Aufield**, **Dorothy Clerke**; executors, **Edward Broughton** and **Mary**, his wife.

The actual donor of these three pieces was probably **Anne Hawes** who, as it seems, placed thereon the initials of her husband and herself.§

* By Mr. Augustus W. Franks, C.B., F.S.A. † Communicated by Mr. William White, sub-librarian.

‡ *Nichols*, Vol. iv., p. 32. § I have to thank the Rev. H. Howlett for this suggestion.

BLABY.

SILVER CUP. Weight 8.5 oz. Height $6\frac{7}{8}$ in. Diam. of bowl $3\frac{5}{8}$ in.; of foot $3\frac{3}{4}$ in. Height of stem 3 in. Date 1637. (PLATE 24.)

Hall marks. 1. Italic V in plain shield. 2. Lion passant in shaped oblong. 3. Leopard's head crowned, with an outside line following its outline. 4. C.C., with three mullets above and a triangle below.

The bowl of this cup is straight-sided in shape, being slightly bell-shaped. The stem is thin and rather short, and has a round between two hollow mouldings for a knob, from whence it swells out into the bowl and foot. The lion passant is repeated underneath the latter.

SILVER PATEN with foot. Weight 2.8 oz. Diam. $4\frac{1}{4}$ in. Diam. of foot $2\frac{1}{8}$ in. Height of foot $\frac{7}{8}$ in. Date 1637. (PLATE 24.)

Hall marks. 1, 2, and 3. As on the cup. 4. I. P., with a pellet above, and a triangle and two pellets below, within a shaped oblong.

This paten is sunk in the middle, and fits on to the cup with the foot downwards.*

SILVER PLATED DISH with foot. Diam. $7\frac{7}{8}$ in. Diam. of foot $3\frac{3}{4}$ in. Height of foot $3\frac{1}{4}$ in.

Mark. W. K., with cross-keys above.

SILVER PLATED DISH. Diam. 9 in.

Mark. Cross-keys within an oblong.

This dish is pentagonal in shape, having a trefoil at each of the five angles on the edge.

SILVER PLATED FLAGON. Height $9\frac{3}{8}$ in. Diam. at top $3\frac{1}{2}$ in.; at foot $4\frac{3}{4}$ in. No marks.

In shape this flagon is straight-sided, with a spout at the top.

PEWTER DISH. Diam. $9\frac{1}{2}$ in.

Marks. 1. X crowned. 2. The golden fleece within an oval, having "Samuel" above, "Ellis" below. 3. "S. Ellis, London," within an oblong. In four small oblongs; (a) The golden fleece. (b) Lion's head erased. (c) Britannia. (d) S. E.

PEWTER DISH. Diam. $9\frac{5}{8}$ in.

Marks. 1. X crowned. 2. London. 3. An eagle displayed with "Thomas" above, "Hodgkin" below.

COSBY.

SILVER CUP. Weight 4.5 oz. Height $5\frac{5}{8}$ in. Diam. of the bowl, and of the foot $2\frac{3}{4}$ in. Height of the stem $2\frac{3}{8}$ in. Date *circa* 1570. (PLATE 21.)

Apparently there are traces of perfectly illegible hall marks near the lip.

In shape the bowl of this cup is an inverted truncated cone, slightly ogee-shaped; round it is a band of stroke ornament divided into four parts by hour-glass curves. The bowl rests on a narrow neck, with a lozenge-shaped ornament running round it, standing on a disk divided into fourteen parts by radii, every other part having a nick in its edge. Under the disk is the usual evenly-balanced stem, a lozenge ornament running round its lower edge. The foot is much as usual, with another band of lozenge work running round it.

* *Vide* Countesthorpe, p. 314.

(a)

SILVER FLAGON. Weight 32.8 oz. Height $9\frac{1}{4}$ in. Diam. at the top 4 in.; at the foot $5\frac{5}{8}$ in. Date 1774. (PLATE 24.)

Hall marks. 1. Capital Roman H in a square shield with an ogree point. 2. Three castles in an oval shield. 3. Lion passant in a shaped oblong. 4. Leopard's head crowned in an oval shield. 5. I. L. in Roman Capitals, a pellet between, and an annulet above, within an oblong lobed at top; the mark of *John Langland*.*

This flagon, which is stamped with the hall marks of Newcastle-upon-Tyne, is straight-sided in shape, narrowing towards the top. It has a long handle of the usual shape, but is entirely without a lid, and no trace of a hinge is now visible on the handle. In front is "*The gift of Mr. Allen Brown, 1776.*" The hall marks are stamped beneath the foot; the maker's mark being in the centre of the other four.

(b)

SILVER CUP. Weight 12.4 oz. Height $7\frac{3}{4}$ in. Diam. of the bowl $3\frac{7}{8}$ in.; of the foot $4\frac{1}{8}$ in. Height of stem $3\frac{3}{8}$ in. Date 1768.

Hall marks. 1. Capital Old English N in a square shield. 2. Leopard's head crowned in an oval shield. 3. Lion passant in a plain oblong. 4. I. P., a pellet between the letters, within an oblong: the I is not very distinct; perhaps the mark of *John Priest*.

This cup has a straight-sided concave bowl, with its lip a little bell-shaped, and a flat base: a baluster stem rising out of a flat foot completes its description. On the bowl is the sacred monogram, with a cross above and three nails below within a circle of glory; and on the top of the foot is "*Dedicated to the service of Almighty God in the parish church of Cosby, by Thomas Paves, lord of the manor, and patron of the church, 1806.*"

SILVER PLATED PATEN. Diam. $9\frac{1}{4}$ in.

This paten is pentagonal in shape, with a gadrooned edge, and much the same in character as a dinner plate. In the centre is the sacred monogram, with a cross above and three nails below in a circle of glory. Round the edge is the same inscription as that on the second cup.

(a)

Allen Brown, the donor of the silver flagon, was the son of **John Brown**, a yeoman of this parish, by **Elizabeth**, his wife, and was baptized here, on 8th March, 1701.† He was churchwarden of this parish in 1751, and helped to pay for the cost of a gallery in the church. He died without issue, and was buried at Cosby, on the 29th March, 1782.‡ **Allen Brown** was twice married: first, on 24th July, 1742, at St. Mary's, Leicester, to **Ann Mansfield**,‡ who died on the 16th, and was buried here on the 19th May, 1777; † secondly, on 24th Sep., 1778, at St. Martin's, Leicester,§ to **Sarah**, third daughter of **Richard** and **Hannah Farmer**, of Leicester,|| and sister of Dr. **Richard Farmer**, Master of Emmanuel Coll., Camb., which lady survived her husband and was remarried to **Richard Jervis**.

By his will, made 13th March, 1780, and proved in Leicester on 17th April, 1782, **Allen Brown** appointed two trustees, his brother-in-law, **Thomas Farmer**, hosier, of Leicester.

* See *Church Plate in the Diocese of Carlisle*, p. 308.
spinster, aged 30, in marriage bond.

† Parish Register.

‡ Described as of Leicester Forest.

§ Parish Register.

|| *Nichols*, Vol. iv., p. 930.

and **Richard Miles**, gent., of Cosby, and left to them in trust, "Ireland House Farm," in Broughton Astley and Croft, his house in Cosby, with land there and in Littlethorpe, for the benefit of his wife, **Sarah**, and his children, if any, and various members of the **Sprigg** family, viz: Sister **Elizabeth**, and her husband, **Richard Sprigg**, of Coventry, their sons, **Allen, Charles**, and **Richard Sprigg**, and also the eldest, second, and third sons of the latter, **Richard Allen, John**, and **James Sprigg**. "My silver cup, which was my late wife's mother's," to **Ann Mansfield**, daughter of **Job Mansfield**, of Desford. Executors, nephew **Richard Sprigg**, and **Richard Miles**.

(b)

Thomas Pares, the donor of the second silver cup and the silver plated paten, sprang of an ancient trading family long settled in Leicester, two members of which were mayors of that borough.* He was the eldest son of **Thomas Pares**, of Leicester, the purchaser of Hopwell Hall, co. Derby, by **Anne**, eldest daughter of **Robert Norton**, of Leicester, attorney, and was born on 28th May, 1746. Mr. **Pares** for many years practised as an attorney in Leicester; in 1776 he bought the site of the Grey Friars in that town, and enlarged the mansion-house. His connection with Cosby arose through his purchase in 1800, of the manor and advowson from **Jervoise Clarke Jervoise**, Esq., at about which time he acquired also an estate at Narborough. Mr. **Thomas Pares**, who was an F.S.A., succeeded at the death of his father, on 21st May, 1805, to the Hopwell Hall estate. He died unmarried on 27th Oct., 1824, and was buried in the family vault in Ockbrook church, co. Derby, near to which is a mural tablet to his memory.

The arms of **Pares** are; *Sable, a chevron Argent, in the dexter chief a crosslet of the second.*

By his will, made 13th Oct., 1824, and proved, with a codicil, P.C.C., 16th May, 1825, Mr. **Thomas Pares**, of Hopwell Hall, and heretofore of Leicester, appointed as his principal heirs, his only brother, **John Pares**, and the latter's two sons, **Thomas**, and **John Tylston Pares**. Executors, **John**, and **Thomas Pares**; **Samuel, Roger**, and **Thomas Miles**.

COUNTSTHORPE.

SILVER CUP. Weight 6.5 oz. Height $6\frac{1}{2}$ in. Diam. of the bowl and of the foot $3\frac{1}{4}$ in. Height of the stem $3\frac{1}{2}$ in. Date 1637. (PLATE 21.)

Hall marks. 1. Italic V in an oval shield. 2. Lion passant in a plain oblong. 3. Leopard's head crowned, with an outside line following its outline. 4. I. P., a pellet above, a triangle and two pellets below, within a shaped oblong.

The bowl of this cup is in shape an inverted truncated cone, with a flat base. The stem is thick and evenly-balanced, swelling out into two vertical ends; in its middle is a large knob. The foot has a large round moulding on its top sloping down into a flat edge. Beneath the foot the lion passant is repeated.

SILVER PLATED PATEN with a foot. Diam. $7\frac{7}{8}$ in. Diam. of the foot $3\frac{5}{8}$ in. Height of foot $3\frac{1}{4}$ in.

Mark under foot: cross-keys within an oblong, W. K. below.

* For pedigree, see *Leicestershire Pedigrees and Royal Descents*, by Rev. W. G. D. Fletcher, p. 123.

SILVER PLATED DISH. Diam. $9\frac{1}{2}$ in.

Mark as on paten.

This dish is pentagonal in shape having at each of its five angles a trefoil.

SILVER PLATED FLAGON. Height $9\frac{1}{2}$ in. Diam. at the top $3\frac{1}{2}$ in.; at the foot $4\frac{3}{4}$ in.

This is a straight-sided flagon narrowing to the top.

PEWTER PLATE.

Marks. 1. Lion rampant, "W. Cooke" on a scroll above. 2. Rose crowned between two pillars.

In 1832 there was here "a small silver paten."

Until 1878 this parish was a chapelry of Blaby, where there was also in 1832 "a small silver paten." Each chapelry seems to have been provided with a cup and paten in the same year, 1637; Mr. Rogers, who was afterwards ejected by the parliament, being then the incumbent. The paten now at Blaby, probably really belongs to the Countesthorpe cup, they were both made by the same maker.

CROFT.

SILVER CUP. Weight 8.7 oz. Height $7\frac{3}{4}$ in. Diam. of the bowl 4 in.; of the foot $3\frac{3}{4}$ in. Height of the stem $3\frac{1}{4}$ in. Date 1789.

Hall marks. 1. Small Roman O in a square shield. 2. Leopard's head crowned in an oval shield. 3. Lion passant in a plain oblong. 4. H. B., in script letters, within an oblong; the B is most indistinct; the mark of *Hester Bateman*.

This cup has a bowl which is straight-sided in the upper, and egg-shaped in the lower part. The stem is a plain round one, swelling out towards the bowl and into the foot, which is quite simple in shape. On the bowl is "*Renewed by the parish of Croft, 1790.*"

SILVER COVER PATEN with a foot. Weight 2.5 oz. Diam. $4\frac{1}{2}$ in. Diam. of the foot $1\frac{3}{8}$ in. Height of foot $\frac{3}{4}$ in. Date 1585.

Hall marks. 1. Capital Roman II in a plain pointed shield. 2. Lion passant. 3. Leopard's head crowned, each of the two last having an outside line following its outline. 4. I. H., two pellets above and two below, within a shaped shield.

This paten has a flat edge $\frac{1}{4}$ of an inch wide, upon which is fixed the usual rim. The main part is sunk in a shallow round. The foot is a disk attached to the paten by a short round stem $\frac{3}{8}$ of an inch thick, swelling out at both ends.

SILVER PATEN. Weight 6.1 oz. Diam. $7\frac{1}{2}$ in. Date 1876.

London hall marks.

This is a perfectly plain paten.

In an undated terrier signed by **Humphrey Haines**, and apparently made in 1724, we are told that the church plate here then consisted of; "A cup and cover to it of silver ye weight about 8 oz; a pewter flagon." It is not unlikely but what the present cup, made in 1790, contains the metal of

the old one. Its lip has been so made as to allow the old cover paten to fit on to it.

The modern silver paten is the gift of the present rector, the Rev. J. Brookes, M.A., who was appointed to this living in 1872.

DES福德.

SILVER CUP. Weight 11.3 oz. Height 8 $\frac{3}{8}$ in. Diam. of the bowl 4 $\frac{1}{8}$ in.; of the foot 3 $\frac{3}{8}$ in. Height of stem 3 $\frac{1}{4}$ in. Date 1736.

Hall marks. 1. Small Roman A in a plain shield. 2. Leopard's head crowned in a plain pointed shield. 3. Lion passant in a plain oblong. 4. F. S., a pellet between, and a fish below the letters, within a heart-shaped shield; the mark of *Francis Spilsbury*.

The bowl of this cup is shaped as an inverted truncated cone, with its lip slightly bell-shaped. The stem is a thick round one, having a large round knob below the middle. At its upper end it swells out into the bowl, at its lower end into a plain foot, finished off with a few round mouldings and a flat edge. The bowl is of one piece of metal, as is also the stem and foot. On the bowl is "*Desford. I. B., I. M., 1736*;" the initials of the two churchwardens for that year, **John Burgess**, and **Joseph Moss**.*

SILVER PATEN with a foot. Weight 8.5 oz. Diam. 7 in. Diam. of the foot 3 in. Height of foot 2 in. Date 1750.

Hall marks. 1. Small Roman P in a shaped shield. 2. Leopard's head crowned in a shaped shield. 3. Lion passant in a shaped oblong. 4. I. W., in script letters, within a plain oblong; mark of *John Wirgman*.

This is a plain flat paten, having a raised edge with a narrow moulding running round it. The foot is a thick hollow drum finished off with a large round moulding. Underneath is "*The gift of Mrs. Eleanor Muxloe, Junr. to the Parish Church of Desford, 1746*."

The paten was purchased in accordance with the following clause in the donor's will, made on 18th Sep., 1745, and proved in Leicester on 9th Nov., 1750; "*I give a silver salver of the value of £5 to be marked with the letters E. M., for the use of the communion table of the parish church of Desford.*" **Ellen**, or **Eleanor, Muxloe** sprang from a family owning land originally in this parish and afterwards in Kirby Muxloe and Pickwell. She was the daughter of **Francis** and **Ellen Muxloe**,† of Desford, and was born in 1708. She died unmarried at Leicester on 10th Oct., 1746, and was buried in the chancel of this church on the 13th.‡ She bequeathed £1 to the poor of Desford to be given in bread at her funeral. Her mother, **Ellen Muxloe**, widow, and her cousin **Edward Ashpinshaw** she appointed executors and residuary legatees. The will was not proved until four years after the testator's death which accounts for the date in the inscription on the paten being that much earlier than the date of the hall marks.

* *Ex. Inform.*, G. H. & T. Nevinson. † "*Francis Muxloe and Helen Muxloe married, 1st April 1704.*" Parish Register, St. Mary's, Leicester. ‡ Parish Register.

ENDERBY.

(a)

SILVER CUP. Weight 14.6 oz. Height 9 in. Diam. of the bowl $3\frac{3}{4}$ in.; of the foot $3\frac{3}{4}$ in. Height of the stem $4\frac{3}{4}$ in. Date 1757.

Hall marks. 1. Capital Roman S in a plain pointed shield; the S appears to be slightly fringed. 2. Leopard's head crowned in a plain shield. 3. Three castles in a heart-shaped shield. 4. Lion passant in a plain oblong. 5. I. L., a gem ring above, within an oblong lobed at the top; the mark of *John Langland*.*

This cup, which is of Newcastle make, has a straight-sided bowl with a narrow moulding round the lip, the inside being gilt. Its stem is narrow; below its middle is a round between two hollow mouldings for a knob. The stem swells out into the bowl and into a plain round foot with some shallow mouldings running round its edge. On the bowl is: "*The gift of Richard Smith, Esq., to the parish church of Enderby, 1762.*"

SILVER PLATE. Weight 15.7 oz. Diam. $9\frac{1}{2}$ in. Date 1759.

Hall marks. 1. Capital old English D in a square shield. 2. Lion passant in a plain oblong. 3. Leopard's head crowned in an oval shield. 4. D. H., a pellet between the letters, within a plain oblong.

This is a plain dish with a flat edge, round which is the same inscription as that on the cup.

SILVER FLAGON. Weight 43 oz. Height $12\frac{1}{2}$ in. Diam. at the top $4\frac{1}{2}$ in.; at the foot $7\frac{1}{2}$ in. Date 1757.

Hall marks as on the cup.

This is a large straight-sided flagon narrowing towards the top. It has a round top to its lid and a large open purchase. In front is the same inscription as that on the cup.

(b)

SILVER PLATE. Weight 9.3 oz. Diam. $8\frac{7}{8}$ in. Date 1848.

Sheffield hall marks.

This is a plain plate, having in its centre the sacred monogram with a cross and three nails within a circle of glory. Round the edge is: "*Presented Dec. 1st, 1848, to the parish of Enderby, by the Rev. J. P. Newby, Vicar. For the use of the Church at the Holy Communion.*"

(c)

SILVER CUP. Weight 14.6 oz. Date 1873.

London hall marks.

This cup is the same in size and shape as the old one. On the bowl is: "*Presented by Mrs. Charles Brook to the church of St. John the Baptist, Enderby, 1874.*"

PEWTER PLATE. Diam. $9\frac{1}{4}$ in.

Marks. 1. X crowned. 2. Eagle rising out of a ducal crown, towards the sun in splendour. 3. "London." 4. In four small shapes; (a) Per chevron engrailed three eagles' heads erased. (b) Eagle's head erased. (c) Sun in splendour. (d) "B & —."

PEWTER BASIN. Diam. $11\frac{3}{4}$ in. Diam. of the foot $6\frac{1}{2}$ in. Height $5\frac{1}{2}$ in.

No marks.

This is a large plain basin standing on a round foot 2 inches in height.

* See *Church Plate in the Diocese of Carlisle*, p. 308.

In the terrier of 1709 the church plate of Enderby is thus described ; "A large pewter flagon ; a silver cup with a cover weighing 9 oz., without inscription." These pieces were not here when the inventory was sent to Archdeacon **Bickham** in 1780.

(a)

The donor of the older portion of this service sprang from a family settled at Preston, co. Lincoln, of which the first member to become connected with this parish was **Richard Smith**, the donor's grandfather, who shared the fortunes of **Charles II.** in his exile, and at the restoration was made Clerk of the Cheque. His grandson, **Richard**, was the son of **Richard Smith**, the purchaser of the manor and a good estate in Enderby with the impropriate tithes of Whetstone, and was born in Filkins, co. Oxford, and baptized in Bradwell church, on 10th May, 1694.* On the death of his father on 5th Nov., 1749, Mr. **Smith** succeeded to the property bought by him in these two parishes. He seems to have married and to have had a son, **Richard**, who died on 23rd Feb., 1757, aged 25, to whom there was once a slab in the chancel floor of this church.† Mr. **Smith** died on 16th April, 1762, and was buried in the chancel here, on the North wall of which is a marble tablet to his memory surmounted with his arms ; *a lion's head erased between three annulets.*‡

By his will made 14th May, 1759, and proved at Leicester, 10th June, 1762, **Richard Smith** left his estates, subject to certain charges, to **Charles Loraine**, second son of his father's first cousin, Sir **C. Loraine**, Bart., of Kirk Harle. Amongst other legacies he bequeathed to **Richard Smith Ward** and **Doraliza Ward**, children of **William Ward**, of Birmingham, £200 each ; £500 to Quarter-Master **William Smith** ; £10, each, to the poor of Filkins and Enderby ; £5 to poor of Whetstone ; £200 to trustees, the interest to pay a school-master appointed by them to teach poor children of Enderby. In a codicil, dated 28th May, 1759, £100 to the same trustees the interest to be paid to the vicar of Enderby, provided he reads prayers twice a week in Lent, strictly observes fast days, catechises the young and prepares them for confirmation ; £500 to Society for the Propagation of the Gospel, and £500 to fund for training boys for the sea service.

Judging from the hall marks Mr. **Smith** possibly made his gift of communion plate shortly before his death, the inscription being engraved thereon after that event.

(b)

The donor of the silver plate, the Rev. **John Pengree Newby**, was the son of **John Newby**, of Cambridgeshire, and was admitted to St. John's Coll. Camb., on 18th July, 1816 ; he took his B.A. and M.A. degrees in 1821 and 1824. He was appointed to the vicarage of Enderby and Whetstone in 1823 and held both parishes till his death on 23rd July, 1858, at the age of 68 ; he was buried in this churchyard. Mr. **Newby** was twice married, his

* Parish Register. † "Richard, son of Richard Smith, Esq., buried 25th Feb., 1757." Enderby Parish Register.

‡ For inscription, now much worn, see *Nichols*, Vol. iv., p. 162.

first wife **Anne**, died at the age of 51, leaving no issue, and was buried here on 3rd Oct., 1839; there is a marble tablet to her memory on the South wall of this church; he married his second wife **Mary Anne**, who is still living, close to 1842, and by her with other children, had a son **John Robert**, born 14th Jan., and baptized here 20th Feb., 1843.*

(c)

Mrs. **Charles Brook**, the donor of the modern cup, was **Elizabeth**, widow of **Charles Brook**, Esq., J.P., of Meltham Hall and Mills, co. York, and in 1865 the purchaser of the greater part of this lordship. After making that purchase Mr. and Mrs. **Brook** resided at the hall here and took the greatest interest in the welfare of this parish. Mr. **Brook** rebuilt the church, with the exception of the tower, built a new vicarage house and enlarged the schools. He was born on 18th Nov., 1813, and died on 10th July, 1872. Mrs. **Brook** continued to live here after her husband's death, taking part in many good deeds, the completion of St. Peter's school, Leicester, begun by Mr. **Brook**, being one. She died on 27th Jan., 1879, aged 64, and was buried with her husband in his own gift to the parish, the new portion of the churchyard. On the South wall of the chancel are two brasses, side by side, to the memory of Mr. and Mrs. **Brook**; the inscription to the former, speaks of him as one "*characterised by singleness of purpose, simplicity of character, humbleness of mind, and large hearted consideration for the interests of others.*" In front of the schools stands a memorial to Mr. **C. Brook**, erected by the inhabitants of Enderby, ugly in design, but a token of the kindly feeling which they bear for his name and worth. Since Mr. **Brook** died without issue his estate here has passed to Capt. **C. G. A. Drummond**, through his wife **Charlotte Amelia**, daughter of Mr. **William Leigh Brook**.

GLENFIELD.

SILVER PLATED CUP. Height $8\frac{3}{8}$ in. Diam. of bowl $3\frac{3}{8}$ in.; of foot 4 in. Height of stem $4\frac{1}{8}$ in.

The bowl of this cup is straight-sided in shape, having in front the sacred monogram, with a cross and three nails within a circle of glory.

SILVER PLATED PATEN. Diam. $9\frac{1}{8}$ in.

SILVER PLATED DISH. Diam. $9\frac{1}{8}$ in.

Both this and the paten are plain in shape, with the sacred monogram in the centre.

SILVER PLATED FLAGON. Height $10\frac{1}{4}$ in.

This flagon is straight-sided in shape, with a spout at the top, and the sacred monogram engraved on one side.

* Parish Register.

PEWTER PLATE. Diam. $9\frac{1}{4}$ in.

On the edge of this plate there are three small marks, only one of which is legible, which is "P. P." Underneath is "A. T." with a crown above.

Glenfield forms part of the peculiar of Groby, and was not in 1832 under the jurisdiction of the Archdeacon.

KIRBY MUXLOE.

SILVER CUP. Weight 13.4 oz. Height $7\frac{1}{8}$ in. Diam. of bowl $4\frac{1}{4}$ in.; of foot 5 in. Height of stem $5\frac{1}{2}$ in. Date 1849.

London hall marks.

The bowl of this cup is globular in shape, the stem and foot being hexagonal; the former having a large hollow knob. The sacred monogram is engraved upon the foot.

SILVER PATEN. Weight 4.1 oz. Date 1849.

This paten has a six-lobed depression in the middle, with the sacred monogram engraved in the centre. Round the edge is: "*Per mysterium sancte incarnationis tue libera nos domine.*"

SILVER FLAGON. Weight 17.2 oz. Height $10\frac{5}{8}$ in. Diam. of top $1\frac{1}{2}$ in.; of foot $4\frac{1}{4}$ in. Date 1849.

This is a jug-shaped flagon, with a spout at the top.

This service is kept in an oak box, on which is a brass plate bearing this inscription: "*This box of communion plate was presented to the church of Kirby Muxloe, by Miss Moore, on Christmas Day, 1849.*"

In about the year 1830* some of the plate belonging to this church was stolen, a small silver plate with an inscription on it being one of the pieces taken away. The only piece of silver which was not stolen was a large cup, thus inscribed: "*1634. This communion cupp is ye gift of Mr. Francis King for the use of the chappell of Kerby Muchlesse in ye parish of Glenfield.*" Unfortunately this cup was sold, at the time the new service was given, in order that the money might be devoted to the expenses of the church.

Francis King, according to *Nichols*, (Vol. iv., p. 782,) was a citizen of London. He bought of King **Charles I.** in 1631, for £1420, 150 acres of land in Leicester Forest.

In his will made 20th Oct., 1639, and proved in Leicester, 29th Aug., 1640, **Francis King**, of Kirby Muxloe, gent., stating that he has already liberally provided for his eldest son **Thomas King**, clerk, leaves to his younger son **Benjamin**, and his heirs, all his houses and lands in Kirby Muxloe and in the late forest of Leicester, subject to an annual rent charge of £60 to his wife **Mary** for life. To daughter **Ann King**, £600. Daughter **Mary Tooke** mentioned. To poor of Kirby Muxloe, £20. To poor of St. Martin's-le-Grand, London, £5. Wife **Mary** and son **Benjamin**† executors.

* Archdeacon Bonney's inventory. † For whose descendants, see *Nichols*, Vol. iv., p. 626, who gives the arms of King as, "Sable on a cross Or, a hand erect and erased of the first."

The donor of the modern service to this church was Miss **Ann Moore**, the eldest daughter of Mr. **John Moore**, by his wife **Isabella Burton**. This lady was born on 25th Aug., 1793, and died unmarried on 11th March, 1855. She was buried in the East end of the churchyard of this parish, by the side of her father and mother and several members of her family; a monument to the memory of seven members of the family stands over the vault. Mr. **John Moore** was a landowner in this parish; his daughter-in-law, **Mary Moore**, gave communion plate to St. Matthew's church, Leicester.*

BRAUNSTONE.

SILVER GILT CUP AND COVER. Weight of cup 13.4 oz. Weight of cover 4.2 oz. Height 10 $\frac{3}{4}$ in. Diam. of bowl 4 $\frac{1}{2}$ in.; of foot 3 $\frac{3}{4}$ in. Height of stem 6 $\frac{1}{2}$ in. Diam. of cover 4 $\frac{1}{2}$ in. Height 6 in. Date 1613. (FIG. 39.)

Hall marks on cup and cover. 1. Lombardic Q in a plain shield. 2. Lion passant. 3. Leopard's head crowned; each of these two having an outer line. 4. R.M., a pellet between the letters, in a shaped shield.

This is a very beautiful standing cup and the only one of the kind belonging to any church in this county, but similar to others elsewhere. It is one of a certain class of hanap that was in fashion for a few years only, and though like others of that group in shape, it is unique in its decoration; for round the bowl is repoussé this design: a landscape with a fox in the foreground on one side, on the other side a hare; between are two hounds, evidently belonging to no Leicestershire pack, for they each leave the fox and chase the hare. On the cover, in the foreground of another landscape, is a fox between two hounds that have apparently been whipped off the hare for they each face the fox. Below the cable moulding round the bowl are two rows of lotus-shaped leaves, which are repeated on the foot. The



Fig. 39. 1613. $\frac{1}{3}$ of full size. M. P. del.

* Page 101.

pyramid on the cover is supported by three brackets, the same number being attached to the baluster stem. The cover is a good deal dented. This was once a secular cup; no record has been found showing by whom or at what time it was presented to this church.

SILVER PATEN with a foot. Weight 8.5 oz. Diam. $7\frac{1}{2}$ in. Diam. of the foot 3 in. Height of foot $1\frac{1}{2}$ in. Date **1721**.

Hall marks. 1. Capital Roman F in a plain shield. 2. Leopard's head crowned in a square shield. 3. Lion passant in a plain narrow oblong. 4. I. L., a pellet above and below in a quatrefoil: Mark of *John Lingard*.

This is a plain flat paten with narrow raised edge; it stands upon a hollow foot ending in a round moulding.

SILVER GILT CUP. Weight 9.7 oz. Height $6\frac{1}{4}$ in. Diam. of bowl $3\frac{3}{8}$ in.; of foot $4\frac{3}{8}$ in. Height of stem 4 in. Date **1858**.

London hall marks.

This cup is a very fair imitation of a mediæval chalice. Its bowl is globular, and has round it this inscription: "*Calicem salutaris accipiam et nomen dñi invocabo.*" The stem and foot are hexagonal in shape, the former having a large hexagonal knob with six bosses, having tracery between them. On one division of the foot is the sacred monogram; on the other five, conventional foliage.

SILVER GILT PATEN. Weight 4.4 oz. Diam. $6\frac{1}{2}$ in. Date **1858**.

The middle of this paten is sunk in a six lobed depression, having in its centre the *Agnus Dei*. Round the edge is: "*Agnus Dei qui tollis peccata mundi miserere nobis.*"

SILVER GILT FLAGON. Weight 15.7 oz. Height $11\frac{1}{8}$ in. Diam. at top $1\frac{3}{8}$ in.; at foot $3\frac{3}{8}$ in. Date **1858**.

This is a jug-shaped flagon with a spout at the top, being the same in shape as the flagon at Kirby Muxloe. Round the middle is: "*Gloria in excelsis Deo alleluia.*"

GILT DISH of base metal. Diam. $7\frac{1}{8}$ in.

Nichols (Vol. iv., p. 620,) mentions the hanap and paten as all the plate belonging to this church.

In 1721 the lord of this manor and owner of most of the soil was **Robert Winstanley, Esq.**

The modern service of communion plate, which is unusually good in make and design, was the gift of the late Mrs. **Winstanley**. This lady was **Mary Frances**, only daughter of the Rev. **William Birch**, for many years a house master at Rugby School, and afterwards rector of Burford, Oxon, by Miss **Jane Bucknill**, of Rugby, and was born on the 1st Aug., 1800. She married on 5th Oct., 1824, the Rev. **George Winstanley**, rector of Glenfield from 1814 till his death in Dec., 1846, at the age of 57. After her husband's death Mrs. **Winstanley** retired to Burford House, Rugby, where she died on 3rd Feb., 1885. She bore her husband two sons and three daughters. The eldest son, **Clement George**, died early; the second **James Beaumont Winstanley**, who never married, was the last of his name to own the Braunstone estate, which came to him from his uncle **Clement Winstanley**,

Esq., and passed, upon his death in 1862, to his eldest sister and co-heir **Mary Frances**, the wife of **Ralph George Pochin**, Capt., R.N. The Rev. **George** and Mrs. **Winstanley** were both buried in the family vault under the chancel of Braunstone church.

NARBOROUGH.

SILVER CUP. Weight 9.4 oz. Height $7\frac{3}{4}$ in. Diam. of the bowl $3\frac{1}{2}$ in.; of the foot $3\frac{1}{4}$ in. Height of the stem $3\frac{3}{4}$ in. Date **1764**.

Hall marks. 1. Capital old English I in a square shield. 2. Leopard's head crowned in an oval shield. 3. Lion passant in a plain oblong. 4. I. P. in script letters, with a pellet between, within a shaped oblong; the mark of *John Payne*.

This cup has a straight-sided concave bowl with a raised lip; and a plain round foot 1 inch thick in the middle, where there is a small moulding for a knob. The stem which swells out at both ends, stands upon a plain foot ending in a round moulding and a flat edge. Upon the bowl is the sacred monogram with a cross above and three nails below within a circle of glory. Round the monogram is: "*This was a gift to the Altar, A.D., 1765.*"

SILVER PATEN with a foot. Weight 8.1 oz. Diam. $6\frac{2}{3}$ in. Diam. of the foot $2\frac{3}{4}$ in. Height of the stem $1\frac{1}{4}$ in. Date **1764**.

Hall marks as on the cup.

This is a plain-shaped paten having in its centre the sacred monogram and the same inscription as that on the cup. The foot is a disk attached to the paten by a round stem swelling out at both ends.

(a)

SILVER PLATE. Weight 8.5 oz. Diam. $7\frac{1}{2}$ in. Date **1764**.

Hall marks as on the cup.

This is a plain-shaped plate with the sacred monogram in the centre encircled with this inscription; "*D.D., Ric's Bridger Rector De *Harbro', A.D., 1765.*"

SILVER FLAGON. Weight 32.2 oz. Height $10\frac{1}{2}$ in. Diam. at the top $3\frac{1}{2}$ in.; at the foot 6 in. Date **1764**.

Hall marks as on the cup.

This is a straight-sided flagon narrowing towards the top, with a round top to its lid. In front is the sacred monogram, round which is: "*This was rais'd by Voluntary Contributions, A.D., 1765.*"

(b)

SILVER CUP WITH A COVER PATEN. Weight 9.7 oz. Height $7\frac{3}{8}$ in. Diam. of the bowl $3\frac{1}{8}$ in.; of the foot $3\frac{3}{8}$ in. Height of the stem $3\frac{1}{2}$ in. Date **1805**.

London hall marks.

This cup has a straight-sided bowl with a flat base, resting on a thin stem which swells out into two small knobs, one near the top, the other in the middle. The stem swells into a plain flat foot. On the bowl is: "*Dedicated to the service of Almighty God in the parish church of Narborough, by Thomas Pares. Lord of the manor and patron of the church, 1805.*"

* The engraver has put "H," instead of "N."

SILVER COVER PATEN with a foot. Weight 3.1 oz. Diam $3\frac{1}{2}$ in. Diam. of the foot $1\frac{5}{8}$ in. Height of foot 1 in. Date 1804.

London hall marks.

This paten is flat, with a vertical rim round its edge $\frac{1}{8}$ of an inch deep causing it to fit on to the cup as a cover. Its foot is hollow, being a plain round drum swelling out at both ends. The top of the paten is gilt. Underneath is: "Narborough Church, 1805."

(a)

Richard Bridger, the donor of the silver plate and perhaps also of the cup and paten, was the third son of **Harry Bridger, gent.**, of Southwick, co. Sussex, ancestor of the **Bridgers** of Buckingham house, co. Sussex, by **Katherine** his wife, and was born on 16th June and baptized on 12th July, 1734, at Southwick.* He was admitted to Hertford College, Oxford, on 28th July, 1750, and took his B.A. degree from Magdalen College in 1754 and M.A. in 1757.† Of the latter College, according to the inscription on his monument, he was at one time a Fellow. Mr. **Bridger** was inducted to the living of Narborough upon the 15th Nov., 1764, which he held till his death; but he does not appear to have resided here much; he lived principally at Ashford, co. Middlesex, where he died without issue on 11th Nov., 1800, and was buried in the churchyard of that parish on the South side of the church, near to his wife **Jane**, who died on the 17th July, 1800, aged 63, and was buried on the 21st.‡

On the outside wall of the old church at Ashford were affixed, close to their graves, two oval white marble tablets bearing short inscriptions to their memory; these are now on the North outer wall of the present modern church. Mr. **Bridger's** will, made 26th Sep., 1800, was proved, with a codicil dated 1st Nov., on 3rd Dec., 1800, P.C.C., by his nephew and executor **Harry Bridger**.

The arms of **Bridger** of Buckingham house, are; *Argent a chevron engrailed Sable, between three crabs Gules.* Crest: *A crab* as in the arms.§

(b)

Mr. **Thomas Pares**, the donor of the second silver cup and cover, became connected with Narborough, at about the time the former donor died, by purchasing the manor, advowson and the old hall, and a considerable part of the lordship, most of which has now passed out of his family.||

NEWTOWN LINDFORD.

SILVER CUP WITH A COVER PATEN. Weight of cup 7.8 oz. Height $7\frac{1}{2}$ in. Diam. of the bowl $3\frac{3}{4}$ in.; of the foot $3\frac{7}{8}$ in. Height of stem 3 in. Date 1683. (PLATE 25.)

Hall marks. 1. Small black-letter F in a plain shield. 2. Lion passant in a plain oblong. 3. Leopard's head crowned in a circle. 4. I. D. crowned, a mullet of six points below, in a plain pointed shield.

* Parish Register. + *Alumni Oxonienses*, Joseph Foster, p. 158. † Parish Register. § *Burke's Landed Gentry*. || *Vide* Cosby, p. 312.

This cup has a straight-sided bowl slightly concave, and a plain round stem without a knob, swelling out gradually towards the bowl and into a plain flat foot, underneath which the lion passant is repeated. Round the bowl is "*Newtowne Linford. The gift of Mercy Milborne and Anne Raworth Widdowes.*" Above the inscription is engraved a small conventional flower, below is the date "1685."

SILVER COVER PATEN with a foot. Weight 2.5 oz. Diam. $4\frac{1}{4}$ in. Diam. of the foot $1\frac{3}{4}$ in. Height of foot $\frac{5}{8}$ in. Date 1683. (PLATE 25.)

On the inside of the paten is stamped the maker's mark only.

This paten is flat in shape with a few lines running round its edge. The foot is a disk attached to the paten by a stem swelling out at both ends.

PEWTER FLAGON. Height 11 in. Diam. at the top $4\frac{3}{8}$ in.; at the foot $5\frac{3}{8}$ in. Mark on the back of the handle, "I. W. R."

This is a straight-sided flagon, narrowing to the top, having a flat top to its lid.

TWO PEWTER PLATES. Diam. of each $9\frac{1}{4}$ in. Date 1675.

Marks. 1. On the edge, K. P. 2. On the back, X crowned. 3. Within an oval an anchor crowned between the date "1675," above is "**Tho. King,**" below "London." 4. Within an oval, a rose crowned between the date "1675," "**Tho. King,**" above, "London," below. 5. Within an oblong, "London." Both these plates are quite plain in shape.

PEWTER PLATE. Diam. $8\frac{5}{8}$ in.

Mark. In three small lozenges, a leopard's face; in a fourth small lozenge, "I. A." Underneath the plate is "N. L." for Newtown Lindford perhaps, and "T. F."

This is a plain flat plate with a raised edge.

PEWTER BASIN. Diam. $8\frac{1}{4}$ in. Height $2\frac{1}{2}$ in.

Marks. 1. "N. L." "T. F." 2. A stag trippant, above, is a name, possibly "**Rowland,**" below, are two palm branches.

This is a perfectly plain basin.

Of the two widow ladies who presented the silver cup and cover, I am not able to tell much. **Mercy Milborne** was buried here on 1st March, 1698-9.* The family of **Raworth** owned Maplewell, which adjoins this parish; and the same family were long connected with Knossington.† Their name also appears in the registers of St. Mary's, Leicester.

OADBY.

SILVER CUP. Weight 7.7 oz. Height 6 in. Diam. of bowl $3\frac{1}{4}$ in.; of foot $3\frac{1}{2}$ in. Height of stem $3\frac{1}{8}$ in. Date 1685.

Hall marks. 1. Small black-letter H in plain shield. 2. Lion passant in a plain oblong. 3. Leopard's head crowned within a circle. 4. I. D., with a crown above in a shaped square.

This cup is an example of one made out of two pieces of silver only. It has a straight-sided bowl with a flat base, beaten out of one piece of metal; its stem and foot being shaped out of another piece. Its stem is 1 inch thick and is quite plain in shape, without a

* Parish Register.

† *Nichols*, Vol. iii., p. 112. Vol. iv., p. 657.

knob, swelling a little into a plain flat foot. In recent years the lip has been strengthened by a band of silver placed round it inside. On the bowl is "*Simon Iliffe, Robert Pick. Churchwardens of Odeby, 1687.*"

SILVER PATEN with a foot. Weight 2.3 oz. Diam. $3\frac{5}{8}$ in. Diam. of foot $1\frac{1}{2}$ in. Height of foot $\frac{1}{2}$ an inch. Date 1685.

No hall marks.

This paten has a flat edge $\frac{3}{8}$ of an inch wide, the centre part being sunk. A few lines are drawn round its edge, and round the edge of the foot. It fits on to the cup, with its foot downwards. On the latter is "*Odeby, 1687.*"

SILVER DISH with a foot. Weight 9 oz. Diam. $7\frac{2}{8}$ in. Diam. of foot 4 in. Height of foot $1\frac{1}{2}$ in. Date 1685.

Hall marks as on the cup.

This dish has a flat edge 1 inch wide, the remaining part within it being sunk. Underneath is the same inscription as that on the cup.

SILVER FLAGON. Weight 18.2 oz. Height $10\frac{5}{8}$ in. Diam. of top $2\frac{3}{4}$ in.; of foot $4\frac{1}{2}$ in. Date 1871.

London hall marks.

This flagon is straight-sided in shape with a spout at the top, and a cross on the lid. Underneath the foot is "*The gift of the Rev. T. Wilkie Gordon, Vicar, 1871, Oadby.*"

PEWTER BASIN. Diam. $9\frac{3}{8}$ in. Depth $1\frac{1}{8}$ in.

Marks. 1. X crowned. 2. "London." 3. An eagle displayed with "Thomas" above and "Hodgkin" below. On the flat edge is "*Thomas Sharpe, Lewis Russell, Churchwardens, Odeby, 1768.*"

In 1832 there was here, in addition to the basin, a pewter flagon and plate, the latter inscribed with the date 1768.

The donor of the silver flagon, who now resides at Cheltenham, was vicar of this parish from 1869 to 1881.

RATBY.

SILVER CUP. Weight 5.6 oz. Height 6 in. Diam. of the bowl $3\frac{3}{8}$ in.; of the foot $3\frac{1}{8}$ in. Height of stem 2 in. Date 1567. (PLATE 21.)

Hall marks. 1. Small black-letter K in a plain shield. 2. Lion passant. 3. Leopard's head crowned; each of the two last having an outer line. 4. Possibly a small black-letter R.

This cup has a deep bowl in the shape of an inverted truncated cone, having a bell-shaped lip and a flat base; and a short evenly-balanced stem divided in half by a knob formed by a thick disk projecting from a fillet. The foot is rounded into a flat edge with the egg and tongue ornament running round it. Round the bowl are two plain bands of stroke ornament without straps.

SILVER FLAGON. Weight 40.3 oz. Height $10\frac{3}{4}$ in. Diam. at the top 3 in.; at the foot $3\frac{3}{4}$ in. Date 1715. (PLATE 25.)

Hall marks. 1. Court-hand V in a plain shield. 2. Britannia. 3. Lion's head erased. 4. C. L., a pellet below, within a heart-shaped shield; the mark of *Joseph Clare*.*

* *Gilda Aurifabrorum*, W. Chaffers, p. 172.

This is a jug-shaped flagon of very solid construction, originally a secular piece of plate, exactly the same in shape as the one given to Foston church by the same donors. On one side of it is "This flaggon was the gift of Charles Skrymsher Boothby, Esq., and of Anne his wife, to this parish. Weighing 40 ounces, 10 Dwt 17Gr." In front instead of the arms of Boothby is the seal of the city of Lichfield (Fig. 40); representing three kings' slain, according to the tradition, together with a thousand Christians at the end of the third century in the persecution of Diocletian; the bodies of the martyrs lie on Borrowcop Hill, the scene of the supposed slaughter; the spires of the cathedral appear in the distance. The seal bearing this badge now used by the corporation of that city was cut in 1688. A handsome standing cup and cover is in the possession of that body, presented by Elias Ashmole the antiquary, a native of Lichfield, on which are three medallions each bearing a martyred Christian.



Fig. 40.

PEWTER PATEN. Diam. $6\frac{3}{4}$ in.

Marks. 1. On the top, "R," for Rathby. 2. Underneath, "L. S." in a shaped oblong. This is a plain paten with a raised edge, round which run a few small mouldings.

Charles Skrymsher Boothby was the second son of Thomas Boothby, of Tooley Park,* being the eldest son of that gentleman by his second wife Hester Skrymsher. He inherited the manor of Foston, which had been bought from the Faunts by one of his family late in the 17th century; the lease of Groby Pool House and other property came to him through his younger brothers dying without issue. He served at one time in the army and died without issue on 6th Dec., 1774, aged 69. Charles S. Boothby married at Peckleton on 18th April, 1753,† Ann, the only child of the Rev. Wingfield Buswell, M.A.,‡ rector of Tickencote and Normanton, co. Rutland, by Margaret his wife; Ann Boothby died on 16th Nov., 1785, aged 65.

Charles Skrymsher Boothby and Ann his wife were both buried in the chancel of Foston church, on the South wall of which Mrs. Boothby placed a marble monument to her husband's memory, now on the East end of the North aisle, on which is a long inscription,§ and at the foot this coat of arms: *Argent on a canton Sable a lion's jamb erect and erased Or; Boothby; impaling; Argent five fusils in fess Gules in chief three bears' heads erased Sable muzzled Argent; Buswell.*

Charles Skrymsher Boothby, "of Groby, Esqre." in his will, made 2nd May, 1768, and proved in Leicester 17th Dec., 1774, left "the Pool House" in Groby, leased from Lord

* See Peckleton. † Parish Register. ‡ Youngest brother of Sir Eusebius Buswell, Bart., of Cadeby, co. Leicester; pedigree, *Nichols*, Vol. iv., p. 578. Marriage bond of Wingfield Buswell, bachelor, and Margaret King, of Cadeby, widow, dated 9 March, 1716. § For which see *Nichols*, Vol. iv., p. 174.

Stamford, to his wife for life, then to his nephew **Charles Boothby Skrymsher*** and his heirs. All freehold land he left to trustees for the use of his children, if any; if none for the use of his wife for life and then to his same nephew; subject to the payment of debts and annuities.

Ann Boothby, "of Rathy, widow," by will made 30th Aug., 1784, and proved P.C.C. 17th March, 1786, left £10 to the clergyman's charity at Market Bosworth; 10 guineas each to the poor of Cadeby and Desford; 5 guineas each to the poor of Groby, Rathy, Peckleton, Newtown Lindford, Foston, Narborough and Huncote; and many bequests in money or jewels; to the following amongst others; niece **Ann Meynell**, nephew **Charles Boothby Skrymsher**, niece **Gertrude Boothby**, niece **Corbet D'Avenant**, aunt **Jane Reeves** of Windsor, niece **Maria**, wife of **Dean Noel**, residuary legatee; to cousin **Horton** of Cannock, "picture of our kinsman **Sir William Boswell**;" to repair the tomb of late uncle **George Boswell** at Stafford £20. Executors; nephew **Thomas D'Avenant** and **Rowney Noel**, D.D., dean of Salisbury.

This and the Foston flagons I take to have belonged originally to **C. S. Boothby's** father, **Thomas Boothby**, by whom they were perhaps bought at the time he married his third wife. That lady, as well as her two predecessors, belonged to Staffordshire; but the precise reason for the Lichfield badge being placed on this flagon I have failed to discover.

It will be noticed that the gift of these two flagons was made more by **Anne** than **Charles S. Boothby**, for he died some years before 1781.

GROBY.

SILVER PLATED CUP. Height $7\frac{1}{4}$ in. Diam. of the bowl $3\frac{1}{2}$ in.; of the foot $3\frac{3}{8}$ in. Height of stem $3\frac{1}{2}$ in.

This cup has a straight-sided bowl, and a plain round stem, knob and foot.

SILVER PLATED PATEN with a foot. Diam. 8 in. Diam. of the foot 4 in. Height of foot 3 in.

This is a plain shaped paten with a raised edge, and thick round hollow foot. In the centre is the sacred monogram, with a cross above, and three nails below within a circle of glory.

SILVER PLATED FLAGON. Height $10\frac{1}{2}$ in. Diam. at the top $3\frac{3}{8}$ in.; at the foot 5 in.

This is a straight-sided flagon narrowing towards the top. On one side of it is engraved the sacred monogram, with the cross, nails and glory. This, and the other two pieces, are copper, silver plated.

TWO PEWTER PLATES. Diam. of each $9\frac{3}{4}$ in.

Marks. 1. X crowned. 2. "Superfine hard Metal."

Groby church was built by **George Harry**, 6th Earl of **Stamford** and **Warrington**, in the year 1841. Possibly this service of communion plate was his gift. It was at any rate bought for this parish at the time the church was built or very soon after.

* Only son of his eldest half-brother, **Thomas Boothby**, who took the name of **Skrymsher**; whose son, **C. B. Skrymsher**, took the name and arms of **Clopton** in 1792, and sold the lordship of **Foston** in the year of his death, 1800." *Nichols*, Vol. iv., p. 171.

STONEY STANTON.

SILVER CUP. Weight 6.5 oz. Height 6 $\frac{3}{8}$ in. Diam. of the bowl 3 $\frac{1}{4}$ in. ; of the foot 3 $\frac{3}{8}$ in. Height of the stem 3 in. Date *circa* 1575. (PLATE 26.)

No hall marks.

This cup closely resembles those stamped with the rose, which mark may have been erased from it when the dents were beaten out and other repairs effected. Its bowl is an inverted truncated cone, slightly concave; running round it is a band of foliage, divided into four parts by hour-glass curves; it has a flat projecting base, with lines running round its edge. The stem, which has a shallow knob, swells out towards the bowl, where it is without the usual vertical edge. This edge is found at the lower end of the stem, and has a reed ornament running round it. The foot is as usual, with the reed ornament repeated round its edge.

SILVER CUP. Weight 9.4 oz. Date 1843.

Birmingham hall marks.

This cup is a more or less faithful copy of the old one. It has a band of Elizabethan ornament round its bowl, but no reeds on its stem. Running round the lip is "*The gift of Mrs. Sarah Boyer, of Hathern, for the use of Stoney Stanton Church, 1843.*"

SILVER PATEN with a foot. Weight 14.3 oz. Diam. 8 in. Diam. of the foot 3 $\frac{3}{8}$ in. Height of foot 1 $\frac{3}{4}$ in. Date 1843.

Birmingham hall marks.

This paten is perfectly plain in shape. Round the middle is a band of foliage in the Elizabethan style, round the outside of which is the same inscription as that on the modern cup.

Mrs. **Sarah Boyer**, the donor of the new cup and paten was the daughter of **Saltor** and **Ann Allday**, of Henley-in-Arden, co. Warwick, and was born in 1761. She married on 17th Sept. 1783, at Wootton Wawen, Mr. **Edward Boyer**, a substantial yeoman of the "Stints House," Hathern, who was born in the same year as herself. Mr. **Boyer** farmed and owned the land at Hathern, which has been in the possession of his family for many years.† It is now the property of his grandson, the Rev. **Robert Buckley Boyer**, M.A.‡ Mrs. **Boyer** who was left a widow on 20th Nov. 1821, died on Christmas Day, 1843, being buried in Hathern churchyard; over her grave is placed a slate headstone, upon which is inscribed her name and the date of her birth and death: a similar mention being also made upon a mural tablet erected by her son, **Richard Boyer**, to the memory of her husband and herself and other members of the family, inside Hathern church. Mrs. **Boyer** was connected with the parish of Stoney Stanton inasmuch as she was the grandmother of Mrs. **Sankey**, the wife of the late rector of this parish, the Rev. **John Sankey**, incumbent here from 1842 to 1875.

* Parish Register. † William Boyer named in the Enclosure Act, 1777, as a landowner. ‡ Superintendent of Missions to Seamen.

THURLASTON.

SILVER CUP. Weight 15.4 oz. Height $7\frac{3}{4}$ in. Diam. of the bowl $3\frac{1}{2}$ in.; of the foot $5\frac{1}{2}$ in. Height of the stem 5 in. Date 1861.

London hall marks.

This cup has a globular-shaped bowl, and hexagonal stem, knob, and foot. The latter is shaped into six lobes, with the sacred monogram upon one of them.

SILVER PATEN. Weight 3.9 oz. Diam. $5\frac{1}{2}$ in. Date 1861.

This paten has a flat wide edge, round which is; "*O Lamb of God that takest away the sins of the world, have mercy upon us.*" In the centre is the Agnus Dei within a circle, gilt.

SILVER FLAGON. Weight 21.5 oz. Height $11\frac{3}{4}$ in. Diam. at the top $2\frac{1}{2}$ in.; at the foot 4 in. Date 1861.

This is a jug-shaped flagon with an ornamental band round the neck, and round the middle "*Glory be to God on high.*" The handle at each end terminates in a fleur-de-lis.

SILVER PLATED FLAGON. Height $11\frac{1}{2}$ in. Diam. at the top $4\frac{3}{4}$ in.; at the foot $6\frac{3}{4}$ in.

This is a large straight-sided flagon, made of pewter silver plated. It has some embossed foliage on the top of its handle. Round the edge of the foot is; "*Thurlaston Church 15th Febr. 1842. William Willey and James Pougher, Churchwardens.*"

OAK ALMS DISH. Diam. $14\frac{1}{4}$ in. Depth $1\frac{1}{2}$ in.

This is a large alms dish made out of oak taken out of York Minster after the fire therein. In the centre is the sacred monogram formed in silver-plated letters.

At Lincoln is a terrier of this parish made in 1638, at the back of which are entered, no doubt in 1709, various additions by **Peter Potter**, rector; amongst which is this account of the church plate; "one silver chalice with a cover without any inscription weighing $6\frac{1}{2}$ oz.; two pewter flagons." These were not here in 1810 (*Nichols*, Vol. iv., p. 997); but there were then here, a silver plate inscribed "*The gift of Mrs. Margery Rooe to the parish church of Thurlston, 1722,*" having this coat of arms in the centre, *Gules, on a bend between three garbs Or, as many crosses formée fitchée of the first; Rooe*; and also a silver cup with the same arms upon it, and this inscription, "*The gift of Mrs. Dorothy Rooe to the parish church of Thurlston, Leicestershire, 1733.*" The plate weighed 14 oz. 17 dwts., the cup 18 oz. 8 dwts.

The donors of these two pieces were the daughters of **Roger Rooe**, of Normanton Turville, in the parish of Thurlston, and of Basset House, by **Mary**, daughter and co-heir of **Nicholas Row**, of Boughton, co. Lincoln. **Margery** was born 3rd March, 1661, and died on 5th July, 1722. **Dorothy** was born in May, 1666, and died in Feb., 1733. Neither of these ladies married. They were buried in the chapel at the East end of the North aisle of Thurlston church, and slabs to the memory of both were placed over their graves: the one to **Dorothy** being still in existence; that one, however, which was placed over the grave of her sister is not to be found. Each of

these ladies must have made her gift by means of a verbal order at the time of her death. Neither of them made a will. Letters of administration were taken out at Leicester at the death of each by their brother **Christopher Rooe**, the last of his name to own the estate of this family in Normanton Turville: * another estate in the same Normanton was for many years owned by the Turvilles.

The expense of the new service of communion plate was defrayed by the Rev. **G. E. Bruxner**, M.A., J.P., patron of the living and one of the principal landowners here, and rector of the parish from 1845 to 1876, in which year he resigned. The two pieces given by the **Rooes** were sold to help to pay for the modern set; as was also a modern silver paten, given by the Rev. **John Peckleton Power**, M.A., when he was curate of the neighbouring parish of Peckleton from 1857 to 1862.†

WHETSTONE.

SILVER CUP. Weight 13.5 oz. Height $7\frac{3}{4}$ in. Diam. of bowl $3\frac{3}{4}$ in.; of the foot $4\frac{1}{8}$ in. Height of the stem 5 in. Date 1880.

London hall marks.

This is a modern cup of the usual shape, having a globular bowl, and hexagonal stem, knob and foot; round the bowl is; "*Calicem salutaris accipiam et nomen Domini invocabo.*" The foot is shaped in six lobes, the sacred monogram being placed on one of them, surrounded by foliage.

SILVER PATEN. Weight 4.4 oz. Diam. $6\frac{1}{8}$ in. Date 1881.

London hall marks.

This paten has a flat edge, round which is; "*Accipite comedite hoc est corpus meum.*" The middle is sunk in six lobes, the sacred monogram surrounded by foliage being in the centre.

SILVER FLAGON. Weight 22.4 oz. Height $10\frac{5}{8}$ in. Diam. at the top $1\frac{5}{8}$ in.; at the foot 4 in. Date 1878.

London hall marks.

This is a jug-shaped flagon, having round its top and neck a band of grapes and vine leaves. Round the middle is; "*Pascha nostrum immolatus est Christus.*"

TWO SILVER PLATED CUPS. Height of each $6\frac{1}{2}$ in. Diam. of the bowl $3\frac{1}{2}$ in.; of the foot $3\frac{1}{8}$ in. Height of the stem $2\frac{1}{2}$ in.

Mark. A bell within an oval.

These are copper cups silver plated. They have egg-shaped bowls, and plain stems swelling out into plain round feet.

TWO COPPER PLATES. Diam. 9 in.

Both quite plain.

COPPER BASIN. Diam. at the top $8\frac{1}{4}$ in.; at the foot $4\frac{1}{4}$ in. Height $3\frac{1}{2}$ in.

Quite plain in shape.

From the terrier of 1709 we learn that there was then here; a pewter flagon and chalice of silver, weight 7 oz. The silver cup was not in existence

* For pedigree of Rooe, see *Nichols*, Vol. iv., p. 1005.

† Vicar of Barkestone from 1873 to 1887; now rector of Goadby Marwood.

in 1832, when the plated cups were in use; the copper pieces were bought soon after that date.

The modern silver service was given on Christmas Day 1881, by Mrs. **Newby**, wife of the vicar of this parish, the Rev. **Richard John Newby**,* assisted by a few of her friends.

WIGSTON MAGNA.

SILVER CUP with cover paten. Weight of Cup 17.8 oz. Height 8 in. Diam. of bowl and of foot $4\frac{1}{2}$ in. Height of stem 4 in. Date **1661**. (PLATE 25.)

Hall marks. 1. Capital old English D in a plain shield. 2. Lion passant. 3. Leopard's head crowned; each of the two latter having an outer line following its outline. 4. W. M., with a mullet between the letters, in a plain shield.

The bowl of this cup is very nearly straight-sided, its lip being slightly bell-shaped. The stem, which has a large round knob in its middle, swells out to the bowl and the foot; the latter being quite plain, with the lion passant repeated underneath. On the bowl is this coat of arms: *Argent, a chevron between three cross crosslets fitchée Sable: Crest; on a wreath a man's head couped at the shoulders proper, enveloped about the neck with a rope Or; Davenport*. On the edge of the foot is: "*Ecclesia de Wigston dedit Georgius Davenport, Clericus, natus ibid.*"†

SILVER COVER PATEN with a foot. Weight 10.1 oz., including some lead in the foot. Diam. $6\frac{3}{8}$ in. Diam. of foot $3\frac{3}{8}$ in. Height of foot 1 in. Date **1661**. (PLATE 25.)

Hall marks. The same as those on the cup.

This is a plain paten with a flat edge, on which is engraved the same inscription as that on the cup. The foot is a disk attached to the cover by the usual concave stem.

PEWTER FLAGON. Height 16 in. Diam. at top $\frac{1}{2}$ in.; at foot 8 in.

This is a large straight-sided flagon with a spout at the top. It is of modern make, and was bought for this church a few years ago.

TWO PEWTER PLATES. Diam. $9\frac{1}{2}$ in.

Marks underneath: 1. X crowned. 2. Within an oval, the golden fleece with two annulets above and two below; above the oval is "**Samuel**," below it "**Ellis**." 3. "**S. Ellis, London**." 4. H. C. 5. In four rounded shields (a) S. E. (b) Britannia. (c) Lion's head erased. (d) The golden fleece.

PEWTER PLATE. Diam. $10\frac{7}{8}$ in.

Marks. 1. X crowned. 2. In four oval shields: (a) Lion's head erased. (b) Leopard's head. (c) Lion passant. (d) Illegible mark. On the edge is "**Samuel Davenport, James Hardy**, Churchwardens, 1756."

TWO PEWTER PLATES. Diam. $10\frac{3}{4}$ in.

Marks. As on the last mentioned plate. On the edge of each of these is "**John Horsepoole, William Lewis**, Churchwardens, 1758."

PEWTER PLATE. Diam. $10\frac{3}{4}$ in.

Marks. As on the plates mentioned first, with the exception of there being no "H.C." On the edge is "**William Johnson, Henry Branson**, Churchwardens, 1759."

* Nephew of Rev. J. P. Newby, p. 318. † "To the church of Wigston, George Davenport, clerk, born in that place, gave this."

In 1612 there belonged to this church a communion cup and cover, of silver, and "two pewter pottes." Two old pewter flagons much out of repair and long disused were sold for old metal about twenty years ago. Possibly they were the "two pewter pottes" mentioned in 1612 as belonging to this church; one of these having been given by **John Bailey** in 1594.* The silver cup and cover was not here in 1832; it may even not have survived the Commonwealth.

The Rev. **George Davenport**, the donor of the silver cup and paten now here was, as the inscription on his gift tells us, a native of this parish: he was the third son of **John** and **Elizabeth Davenport**, and was baptized here on 21st Jan., 1631. He was sent to Emmanuel College, Cambridge, of which his eldest brother **John** was a fellow, and took from thence his M.A. degree on 1st May, 1653.† At the restoration we find him in the diocese of Durham, holding the appointment of private chaplain and librarian to Bishop **Cosin**, an employment no doubt much to his taste, as he was a considerable scholar. After he had resided for sometime in the Bishop's family, Mr. **Davenport** was presented by him in 1664 to the living of Houghton-le-Spring, which he held till his death. He died unmarried, and was buried in Houghton-le-Spring church. A large slab was placed over his grave in the chancel.

This slab is now in the floor of the North transept, having been placed there when the church was restored in 1859; it has the following inscription on it: "*Here lieth ye Body of ye Reverend and Charitable Mr. George Davenport, late Rector of this Church, who died July ye 6, 1677. He rebuilt ye parsonage House, ye Chappell, and ye walls about ye Gardens and repaired ye outhouses. He built one half of the Hospitall in ye Churchyard, bequeathed for ye maintenance of 3 poor people in it £160. also £40 to ye poor Stock and £10 to be given to ye poor at his funeral. He was a great Benefactor to Bough Church and gave 70 Manuscripts to ye Bishop's Library in Durham.*"

*If the Soul's transmigration were believed,
You'd say good Gilpin's‡ soul he had received,
And with as liberal hand did give, or more
His daily charity unto the poor;
For which, with him, we doubt not he's posed
Of righteous mens reward—eternal rest.*

Ps., cxii, 6. "The righteous shall be had in everlasting remembrance." In the middle of the inscription is a large medallion containing Mr. **Davenport's** coat of arms and crest.

The parish of Houghton-le-Spring is still in the enjoyment of the benefactions made to it by its former rector. And in addition to the silver communion cup and cover given by him to Wigston, Mr. **Davenport** left to this parish the sum of £20 to be added to the poor stock. His lands at Bushby and Wigston he left to his eldest brother **John**, vicar of Wigston. Will dated 17th Sept. 1676.§

* See *Churchwardens' Accounts*, given by *Nichols*, Vol. iv., p. 385. † *Bennett's Book*, Emm. Coll. Camb. In list of Fellows: "Jno. Davenport, 1649, Leicestershire, deposed for not taking the engagement 1654." Ibid ‡ Rector of Houghton 1558 to 1583. § For pedigree of Davenport of Wigston, see *Leicestershire Pedigrees*, by Rev. W. G. D. Fletcher, p. 32.

GUTHLAXTON SECOND DEANERY.

ASHBY PARVA.
BITTESWELL.
BROUGHTON ASTLEY.
CATTHORPE.
CLAYBROOKE WITH

WIBTOFT AND
WIGSTON PARVA.
COTESBACH.
DUNTON BASSETT.
FROLESWORTH.
LEIRE.

LUTTERWORTH.
SAPCOTE.
SHARNFORD.
SHAWELL.
SWINFORD.

ASHBY PARVA.

SILVER CUP. Weight 12 oz. Height 7 in. Diam. of the bowl $3\frac{5}{8}$ in.; of the foot $4\frac{5}{8}$ in. Height of the stem $4\frac{3}{8}$ in. Date 1864.

London hall marks.

This cup has a globular-shaped bowl, hexagonal stem and knob, and a plain round foot. On the bowl is the sacred monogram within a circle.

SILVER PATEN with a foot. Weight 7 oz. Diam. 7 in. Diam. of the foot $3\frac{1}{8}$ in. Height of the foot $1\frac{5}{8}$ in. Date 1864.

This paten has a wide flat edge, the middle part being sunk. In the centre is the sacred monogram within a circle, gilt.

GLASS CRUET WITH A SILVER STOPPER.

In the terrier of 1709 the church plate belonging to Ashby Parva is thus named; "Communion cup and cover to it both of silver, weight 7 oz. 17 dwts.; a little pewter flagon."

These pieces, together with a pewter plate and basin, were here in 1832. They were parted with as far as I have been able to learn when the modern pieces were presented by the Rev. **Arthur Bouchier Wrey**, M.A., vicar of St. Marychurch, Torquay, who was rector of this parish from 1864 to 1870.

BITTESWELL.

(a)

SILVER CUP. Weight 12.1 oz. Height $6\frac{5}{8}$ in. Diam. of the bowl $4\frac{3}{8}$ in.; of the foot $4\frac{1}{2}$ in. Height of the stem 2 in. Date 1674. (PLATE 26.)

Hall marks. 1. Capital old English R in a pointed shield. 2. Lion passant. 3. Leopard's head crowned, each having an outside line following its outline. 4. K. S., a mullet above and below, within a shaped shield.

This cup has a deep straight-sided bowl slightly concave, with a bell-shaped lip and a flat base. Its stem is unusually short and thick, swelling out, without a knob, into a flat foot, under which the lion passant is repeated. The bowl is beaten out of one piece of metal, the stem and foot out of another. On the bowl is: "*Ex dono Barbarah Goadbey, alias Sutton.*"

(b)

SILVER PATEN with a foot. Weight 9.9 oz. Diam. $6\frac{1}{8}$ in. Diam. of the foot $3\frac{3}{8}$ in. Height of the foot $1\frac{3}{8}$ in. Date 1839.

London hall marks.

This is a perfectly plain paten, having in its centre the sacred monogram, with a cross and three nails, within a circle of glory. On the foot is: "*The gift of Mary Powell, 1839.*"

SILVER PLATE. Weight 12.2 oz. Diam. $8\frac{1}{8}$ in. Date 1839.

This is a plain plate corresponding to the paten. It has in its centre the sacred monogram arranged in the same way, and underneath is the same inscription.

(c)

SILVER CUP. Weight 12.3 oz. Height $7\frac{3}{8}$ in. Diam. of the bowl $3\frac{7}{8}$ in.; of the foot $3\frac{3}{8}$ in. Height of the stem $3\frac{1}{2}$ in. Date 1846.

London hall marks.

This cup has an hexagonal shaped bowl, narrowing to the stem, which with the knob is also hexagonal in shape, as is also the foot. On one side of the bowl is the sacred monogram with a cross, within a circle of glory; and on the opposite side: "*In memory of one to whom Christ was precious.*" Underneath the foot is: "*Bitteswell Parish Church. James Watson died 10th January, 1847, aged nine years.*"

(a)

Barbara Goadbey, the donor of the ancient silver cup to this parish, came of a family which has long been settled in Bitteswell, and in the villages adjoining to it. As far back as the beginning of the 16th century we find **William Sutton** occupying a farm here belonging to the hospital in Coventry.* Many members of this same family of **Sutton** are still in this neighbourhood, most of them being in humble positions. The parish register tells that **Barbara Sutton** was born in 1594, her father being **John Sutton**. On 17th May, 1623, she was married in this church to **Richard Goadbey**. How long her husband lived, and whether any children were born of the marriage, does not appear, apparently **R. Goadbey** and his wife lived elsewhere. But on the death of her husband, **Barbara Goadbey** came back to live in her native parish of Bitteswell; and according to the inscription on the cup, seems to have passed amongst her neighbours by her maiden name as well as by the name she took on her marriage. The following entry in the register mentions her death: "**Barbara Goadbey**, widow, was buried here 10th March, 1676."

In her will made on 20th Feb., 1676, and proved in Leicester on 3rd May, 1677, **Barbara Goadby**, "of Bitteswell, widow," left to the poor of this place £4, and various small legacies to **Robert Sutton**, and his sons, **Joseph**, **Benjamin**, and **David**; to **Elizabeth**, wife of **George Stoe**, of Gayton, Northants; to cousin **John Goadby**, of Earl Shilton; kinsman **Samuel Goadby**, citizen of London; cousin **Joseph Sutton**; all legacies to be paid out of a debt owing by Mr. **William Wickman**, founder and citizen of London. **George Castell**, of Bitteswell, clerk, executor.

* See *Nichols*, Vol. iv., p. 42.

(b)

Mary Powell, the donor of the silver paten and plate, was the daughter of the Rev. **James Powell**, rector of this parish from 1789 to 1844, by his wife, **Mary**,* daughter of **Richard Twining**, Esq., of the Strand. After her father's death she continued to live in this parish in the house built for that purpose by Mr. **Powell**. She died unmarried, on 24th April, 1875, in the 82nd year of her age, and was buried in this churchyard; where is a monument to the memory of different members of her family, on which her own name is briefly recorded. The Rev. **James Powell** and his daughter, as well as other members of his family, have been great benefactors to this parish, as is shewn in its church, schools, and almshouses.

In her will, made 10th Oct., 1872, and proved in Leicester on 28th May, 1875, **Mary Powell** left many legacies to relatives and friends: amongst others, to **Margaret Twining**, daughter of late uncle Rev. **Daniel Twining**; to four daughters of late uncle **Richard Twining**; to cousin Rev. **Edward Smythies**, of Hathern; all real estate in Bitteswell or elsewhere and residue of personalty to cousin **Richard Twining**; to vicar of Bitteswell for time being, Rev. **E. Smythies**, and **R. Twining**, £500 in trust, the interest to be spent in teaching on Sunday as many poor children in Bitteswell, as trustees think well, in principles of Christianity, according to the doctrines of the Established Church of England. Executors: **Richard** and **Samuel Harvey Twining**.

(c)

The modern silver cup was presented by **Thomas** and **Anne Tyrer Watson**, of Lutterworth and Bitteswell, in memory of their son, **James**.

BROUGHTON ASTLEY.

SILVER CUP. Weight 13.1 oz. Height 8 in. Diam. of the bowl $3\frac{3}{4}$ in.; of the foot 4 in. Height of the stem 4 in. Date 1718. (PLATE 32.)

Hall marks. 1. Capital Roman C in a plain shield. 2. Britannia. 3. Lion's head erased. 4. Capital A N in monogram and a small E within a shaped stamp: the mark of *Anthony Nelme*.



Fig. 41.

This cup has a straight-sided bowl with a raised edge round the lip. The stem has in its middle a large round moulding on a fillet for a knob, from whence it swells out into the bowl and foot, the latter being finished off with a large round moulding and a few small ones running round its edge. Underneath the foot is repeated the lion's head erased. On the bowl is this coat of arms; *Quarterly*; 1 and 4, *Azure two bars engrailed Argent, in chief three leopards' faces Or*; **Wright**; 2 and 3, *Or a chevron Vert between three castles Gules*; **Onebye**. (FIG. 41.) Beneath the arms is; "The Gift of Sr Nathan Wright late Lord Keeper of the great Seal of England, 1718."

* Married 6th Aug., 1789; died 18th Jan. 1794, aged 23.

SILVER PATEN with a foot. Weight 4.8 oz. Diam. $4\frac{1}{2}$ in. Diam. of the foot $2\frac{1}{8}$ in. Height of foot $\frac{7}{8}$ in. Date 1718. (PLATE 32.)

Hall marks as on the cup.

This is a flat-shaped paten with a raised round edge $\frac{1}{4}$ of an inch wide. The foot is a disk attached to the paten by a thick round stem swelling out at both ends. On the foot is the donor's crest: *Out of a ducal coronet Or a dragon's head Vert gorged with a collar indented Or.* (FIG. 42.)

SILVER FLAGON. Weight 10.6 oz. Height $8\frac{1}{4}$ in. Diam. at the top $1\frac{3}{4}$ in.; at the foot $3\frac{3}{8}$ in. Date 1848.

London hall marks.

This is a small jug-shaped flagon standing on a round foot. Round its middle is: "*Gloria in excelsis Deo pax hominibus.*"

PEWTER PLATE. Diam. $9\frac{3}{8}$ in. Depth $\frac{3}{4}$ in.

Marks. 1. Eagle displayed with an illegible name below. 2. "London."

This plate has a flat edge $1\frac{1}{4}$ in. wide, the middle part being sunk like a shallow basin.

Sir Nathan Wright, the donor of the silver cup and paten, sprang from a younger branch of an Essex family,* and was the eldest surviving son of the Rev. Ezekiel Wright, B.D., rector of Thurcaston, co. Leicester, by Dorothy, second daughter of John Onebye, Esq., of Hinckley, co-heritor to her brother Sir John Onebye, Knt., and was born at Thurcaston on 11th Feb., 1653. He was educated at Emmanuel College, Cambridge, from whence he entered the Inner Temple and was called to the bar, where in due time he gained what Lord Campbell† calls "a considerable share of plodding business." In 1680 Nathan Wright was elected recorder of Leicester, towards which borough he always bore a firm friendship, typified by the loving cup which he presented to the corporation,‡ now the property of Miss Waldo Sibthorp, of the Minster Yard, Lincoln. He gained a further step in his profession in 1692, when he was made Sergeant-at-Law, and in 1695 when he was made a King's Sergeant before the beginning of Hilary term, and knighted by King William III. on 20th Dec., this latter promotion being due to his having been counsel for the King in the prosecution of Sir John Fenwick. By a happy chance for Sir Nathan Wright, two lawyers more eminent in their profession than himself refused in 1700 the offer of the Lord Chancellorship, which had become vacant through the deprivation of Lord Somers, they being unwilling to succeed so great a man; their refusal resulted in this high position being offered to Sir Nathan Wright, to whom the great seal was given with the title of Lord Keeper, by King William, on 21st of May; Sir Nathan was sworn a member of the Privy Council, but was not



Fig. 42.

* For pedigree see *Nichols*, Vol. iii., p. 219. † *Lives of the Lord Chancellors.* ‡ Sold with the rest of the Corporation plate in 1836, for £21 6s. 2d.; weight 60 oz. 18 dwt.

made a peer. Queen **Anne** reappointed him, and in handing him back the great seal, told him that "she would not have done so if there had been a worthier man in the kingdom to whom she could have delivered it." He remained Lord Keeper until Oct., 1705, when he received his dismissal chiefly through the influence of **Sarah** Duchess of **Marlborough**. Though all authorities agree in saying that Sir **Nathan Wright** was hardly equal to the high position to which he was called by "chance more than choice," he at any rate fulfilled the duties of it with much honesty and uprightness. After his dismissal, he retired to his property at Caldecote, Warwickshire, which he had bought of the **Purefoys**. He was connected with Broughton Astley by the purchase of the manor and estate of the Earl of **Stamford** in 1679. He also bought the manor of Brooksby in this county, upon the death of Sir **William Villiers** last bart., in 1711. Sir **Nathan Wright** married on 6th July, 1676, at St. Andrew's, Holborn,* **Elizabeth**, second daughter of **George Ashby**, Esq., of Quenby; by which lady, who died on 21st July, 1705, he had with several other children, an eldest son **George**, who purchased Gayhurst, co. Bucks, whose grandson **George**, of Gayhurst, sold the Broughton Astley property. The latter's only surviving child, **Anna Barbara Wright**, succeeded to the family estates, and, dying unmarried in 1830, was succeeded by her cousin **George Thomas Wright-Wyndham**, who died in his minority. Sir **Nathan Wright** died on 4th Aug., 1721, and was buried at Caldecote, from whence about two years afterwards, his body was removed to Gayhurst, a white marble mural monument bearing his arms and an inscription in latin still exists in Caldecote church.

The modern silver flagon was bought by the parishioners at the cost of £10, on 7th Jan., 1851.

CATTHORPE.

SILVER CUP WITH COVER PATEN. Weight of Cup 4 oz. Height 5½ in. Diam. of the bowl, of the foot, and height of stem 2¾ in. Date 1568. (PLATE 27.)

Hall marks. 1. Small black letter L in plain shield. 2. Lion passant. 3. Leopard's head crowned: each of the two last marks having an outside line following outline of mark. 4. I P in shaped shield.

This is one of the smallest and prettiest of the Elizabethan cups in this county. Its bowl is shaped into an inverted truncated cone, round which are two bands of foliage, each divided by four hour-glass curves. The stem is of the usual evenly-balanced shape having a large round knob ornamented with rows of little strokes: the same ornament being repeated round the foot.

SILVER COVER PATEN. Weight 1.2 oz. Diam. 2¾ in. Diam. of foot 1½ in. Height of foot ¾ of an inch. Date 1568. (PLATE 27.)

Hall marks as on the cup.

* Parish Register.

On the foot the date "1569" is engraved. This paten has the usual raised rim round the inside edge. Round the top is a band of stroke ornament.

PEWTER FLAGON. Height $11\frac{1}{4}$ in. Diam. at top $3\frac{1}{2}$ in., at foot $5\frac{1}{4}$ in.

The only mark is "C. C." for "Cathorpe Church."

This flagon is in shape straight-sided, narrowing a little towards the top. It has an R shaped handle.

PEWTER DISH. Diam. 9 in.

Marks. "C. C." and three shields containing: 1. A Fleur-de-lis with two mullets above. 2. A Fleur-de-lis with lion rampant above, and a pellet in each corner. 3. Leopard's head.

PEWTER DISH. Diam. 9 in.

Marks. "C. C." "London" and this coat of arms, per chevron engrailed, three lions' heads erased.

CLAYBROOKE WITH WIBTOFT AND WIGSTON PARVA.

(a)

TWO SILVER CUPS. Weight of each 10.5 oz. Height 8 in. Diam. of the bowl 4 in.; of the foot $3\frac{5}{8}$ in. Height of stem $3\frac{3}{4}$ in. Date 1846. Sheffield hall marks.

Each of these cups has a straight-sided bowl, resting on a stem with a plain knob. In front of the bowl is the sacred monogram, with a cross above and three nails below.

(b)

SILVER PATEN. Weight 2.6 oz. Diam. 5 in. Date 1874.

This paten is sunk in the centre and is quite plain in shape.

(c)

SILVER PLATED CUP. Height $6\frac{1}{2}$ in.

This cup has a baluster stem, and the sacred monogram in front of the bowl.

SILVER PLATED PATEN. Diam. $6\frac{1}{8}$ in.

This is a plain paten, having the sacred monogram in the centre.

PEWTER FLAGON PLATED. Height $10\frac{5}{8}$ in. Diam. at top $3\frac{1}{4}$ in.; of foot $5\frac{3}{8}$ in.

This flagon is straight-sided in shape.

PEWTER DISH PLATED. Diam. $9\frac{1}{8}$ in.

Mark, X crowned.

PEWTER DISH. Diam. $8\frac{5}{8}$ in.

Marks. 1. These arms: per chevron engrailed three lions' heads erased, "S. Dunan" below. 2. "London." 3. "Claybrook Church" in large letters, engraved right across the plate.

PEWTER BASIN. Diam. at top $5\frac{7}{8}$ in.; at the foot $3\frac{3}{8}$ in. Height $3\frac{1}{2}$ in. (PLATE 28.)

Mark, X crowned, with "H. I." below.

This basin, perhaps a porringer originally, was formerly placed in the font and used for baptisms. It has the appearance of being possibly two hundred years old.

In the terrier of 1708 the church plate of Claybrooke is mentioned as follows: "A silver cup without a cover or inscription weighing $15\frac{1}{2}$ oz.; a pewter flagon and two pewter plates." While the pewter pieces are still here, the silver cup has vanished sometime ago. It was here in Archdeacon **Bonney's** time, who describes it as "a handsome silver cup." But it disappeared before the purchase of the two silver cups now here, for before that time a German made glass cup with views of German towns upon it was used for the celebration of the Holy Communion in this church; a smaller similar glass cup being taken over for the same purpose to the Chapelries of Wibtoft and Wigston Parva; both have been shown to me.

(a)

The following is the extract from the churchwardens' accounts concerning the purchase of these two cups. "Oct. 9th, 1847. Messrs. Cort's bill for the communion plate £12 13s. od." They were paid for out of the income derived from the church land belonging to the parish church.

(b)

The silver paten was given by the Rev. **T. C. V. Bastow, M.A.**, curate here from 1875 to 1877, and now rector of Peatling Parva.

(c)

The plated cup and paten have been given recently, during the incumbency of the present vicar, the Rev. **C. F. Hayter**; during whose time also, the flagon and pewter plate have been plated. There is no plate belonging specially to either Wibtoft or Wigston Parva, this communion plate being used in all three churches alike.

COTESBACH.

SILVER CUP WITH COVER PATEN. Weight of cup 5.6 oz. Height $5\frac{1}{4}$ in. Diam. of bowl $3\frac{7}{8}$ in.: of foot $3\frac{3}{4}$ in. Height of stem $2\frac{3}{8}$ in. Date 1582. (PLATE 27.)

No hall marks.

The bowl of this cup is in shape an inverted truncated cone, swelling out into a very wide projecting lip, which causes some inconvenience in the use of the cup. Round the bowl there is a band of stroke ornament, divided into four parts by hour-glass curves. The base of the bowl is flat and projecting, having a small moulding round the edge. This cup is a very early example of those that have a conical shaped stem and foot.

SILVER COVER PATEN with foot. Weight 1.9 oz. Diam. $4\frac{1}{4}$ in. Diam. of foot $1\frac{1}{4}$ in. Height of foot $\frac{7}{8}$ in. Date 1582. (PLATE 27.)

No hall marks.

The date "1582" is engraved on the foot; and round the edge of the foot is a narrow band of ornament formed by a succession of strokes, each in the shape of a capital Roman I. There is the usual rim inside the cover, which fits loosely on to the cup.

(a)

SILVER PATEN. Weight 4.3 oz. Diam. 6 $\frac{3}{8}$ in. Date 1845.

This paten has the sacred monogram in the centre, and round the edge: "*Per mysterium sancte incarnationis tue libera nos domine.*"

(b)

SILVER FLAGON. Weight 9.2 oz. Height 8 $\frac{3}{8}$ in. Date 1844.

This flagon is jug-shaped, and has a spout rising from the lower part of its side. Underneath is "*In honorem Dei d.d 7. D. et C. Watson.*"

PEWTER FLAGON. Height 9 $\frac{1}{2}$ in. Diam. at top 3 $\frac{7}{8}$ in.; of foot 5 $\frac{3}{8}$ in.

Marks. 1. Lion passant in an oblong, repeated four times on the lid. 2. R.S. with rose above, inside on the bottom of the flagon.

This is a straight-sided flagon, narrowing a little towards top with a flat top to its lid.

PEWTER DISH. Diam. 8 $\frac{3}{8}$ in.

Marks. 1. Capital Roman C on edge, for "Cotesbach." 2. A rose crowned. 3. A rose with a bird on it. 4. London.

PEWTER DISH. Diam. 8 $\frac{3}{8}$ in.

Marks. 1. A rose crowned. 2. An eagle displayed. 3. "London."

In the terrier of 1709 the silver cup and cover and pewter flagon are mentioned.

(a)

The modern silver paten was the gift of the Rev. **James Powell Marriott**. This gentleman was the eldest surviving son of the Rev. **Robert Marriott**,* rector of Cotesbach, by **Anne**, daughter of **James Powell**, Esq., of Clapton, co. Middlesex, and was born on the 21st July, 1819. He was educated at Ball. Coll. Oxford, from whence he took his B.A. degree in 1841, and M.A. in 1847. Upon the death of his father in 1841, Mr. **Marriott** succeeded to the lordship of Cotesbach, which had been purchased by his grandfather, the Rev. **Robert Marriott**, in 1765; and in 1844 he was inducted to the rectory, which he held till his death on 10th Oct., 1871. The Rev. **J. P. Marriott** married on 19th Dec., 1844, **Lucy Henrietta** only daughter of Sir **George Strickland**, Bart., M.P., by his first wife **Mary**, only child of the Rev. **Charles Constable**, of Wassand, co. York. Upon the death of Lady **Strickland** in 1865, her daughter Mrs. **Marriott** succeeded to the **Constable** property at Walcot, near Brigg co. Lincoln, when she and her husband took the name and arms of **Goulton Constable** instead of **Marriott**. Mrs. **Goulton Constable** died on 8th July, 1871. The Rev. **James Powell** and Mrs. **Goulton Constable** were buried at Cotesbach in the family vault, over which is a solid stone monument bearing a recumbent ornamental cross.

The present owner of Cotesbach is **Charles Marriott**, Esq., the eldest surviving son of the late Rev. **J. P.** and Mrs. **Goulton Constable**; their

* For pedigree see *Burke's Landed Gentry*.

second son, **James**, succeeded to the estate at Walcot, and took, in 1872, the name of **Goulton Constable**. The arms of **Marriott** of Cotesbach, are: *Argent three bars Azure on a canton Sable a fleur-de-lis of the first*. The arms of **Constable**, of Wassand, are: *Quarterly, Gules and Vaire, over all a bend Or*.

(b)

The silver flagon was presented by the Rev. **John David** and **Caroline Watson** on their wedding day. Mr. **John David Watson**, was the nephew of **Joshua Watson**, and the son of the Ven. **John James Watson**, D.D., rector of Hackney, and Archdeacon of St. Alban's, by his wife **Caroline**, daughter of **David Powell**, Esq., of Clapton and St. Helen's, London, merchant, and was born on 3rd Nov. 1804. He graduated from Trinity College, Cambridge, taking his B.A. degree in 1827, and M.A. in 1836. In the former year he was ordained deacon by the Bishop of London, and licensed to a curacy in his father's parish which he held for two years, when he received priest's orders from the Bishop of Worcester, and was appointed to the curacy of Wellsbourne co. Warwick. From thence he went in 1830 to Guilsborough, co. Northants, serving under the Rev. **T. Sikes**, whom he succeeded as vicar, in 1835. There he carried on the work ably begun by his predecessor, making an excellent parish priest; the chancel roof and seats, the peal of five bells, and notably the handsome altar, were his benefactions to Guilsborough church. He died on 12th January, 1864, and was buried by the side of his wife in his parish churchyard, a plain headstone marking the site of their graves. **J. D. Watson** married at Cotesbach, on 13th Sept., 1836,* **Caroline**, second daughter of the above-mentioned Rev. **Robert** and **Anne Marriott**, who was baptized at Cotesbach, on 13th Dec., 1815.* This lady having borne her husband three sons and four daughters, the eldest of whom is Rev. **J. S. Watson**, rector of Lowick, died in Aug., 1857.

DUNTON BASSETT.

SILVER CUP. Weight 15.4 oz. Height 9 $\frac{1}{8}$ in. Diam. of bowl 4 in.; of foot 4 $\frac{1}{4}$ in. Height of stem 4 $\frac{3}{4}$ in. Date 1763. (PLATE 25.)

Hall marks. 1. Capital old English H in plain shield. 2. Leopard's head crowned in plain shield. 3. Lion passant in oblong. 4. C. T. W. W. in a circle; the mark of *Thomas Whipham* and *Charles Wright*.

The bowl of this cup is straight-sided and somewhat bell-shaped. It has a baluster stem, and plain round foot. Some lead has been placed in the stem.

SILVER PATEN with foot. Weight 13.9 oz. Diam. 8 $\frac{1}{2}$ in. Diam. of foot 3 $\frac{3}{8}$ in. Height of foot 2 $\frac{1}{8}$ in. Date 1763.

Hall marks as on the cup. The paten is quite plain in shape.

* Parish Register.

SILVER PLATED FLAGON. Height $10\frac{3}{8}$ in.

This is a plain jug-shaped flagon.

In the terrier of 1709 this church is said then to have possessed; "A communion cup of silver, weight 6 oz. or thereabouts; a pewter plate and a flagon." None of these pieces existed in 1832.

The **Paynes** were the principal landowners here at the time when the cup and paten were procured for this parish. **John Payne** and **René Payne** repaired the chancel of the church in 1751.*

The silver plated flagon was presented in 1882 by Miss **Packman**.

FROLESWORTH.

SILVER CUP WITH COVER PATEN. Weight of cup 10.5 oz. Height $6\frac{3}{8}$ in. Diam. of bowl and of foot $3\frac{7}{8}$ in. Height of stem $3\frac{1}{4}$ in. Date 1662. (PLATE 26.)

Hall marks. 1. Capital old English E in a plain shield. 2. Lion passant. 3. Leopard's head crowned; each of these two last marks having a line following its outline. 4. I. S. with a rose and two pellets below in a plain shield.

The bowl of this cup is straight-sided in shape, with a bell-shaped lip and rounded base resting on a baluster stem. The foot is perfectly plain, and has the lion passant repeated underneath it.

SILVER COVER PATEN with a foot. Weight 1.9 oz. Diam. $3\frac{7}{8}$ in. Diam. of foot $1\frac{1}{8}$ in. Height of foot $\frac{3}{8}$ of an in. Date, *circa* 1575. (PLATE 26.)

No hall marks.

This cover paten has every appearance of having belonged to an older cup than the one now here. The main part of it is sunk in a flat round, the usual rim running round the inside. The foot is a disk, attached to the paten by a straight round stem. Round the top of the paten is a band of stroke ornament, divided into four parts by hour-glass curves. There is also a narrow band of stroke ornament round the edge of the foot. The paten is somewhat bent; if straight it would fit on to the cup with the rim inside.

PEWTER PORRINGER with two handles and a Cover. Height of porringer $5\frac{3}{8}$ in.; of cover $2\frac{5}{8}$ in. Diam. of top $5\frac{1}{4}$ in.; of foot 4 in. Date, *circa* 1700. (PLATE 32.)

No marks.

This is a fluted porringer, a pewter imitation of the silver porringer made so frequently of high standard silver, and it has evidently been originally a piece of secular plate. It is now used as a flagon.

PEWTER DISH. Diam. $9\frac{1}{8}$ in.

Marks. 1. Between two pillars a hare supporting an altar flaming, "Edward," above, "Leapidge" below. 2. "E. Leapidge, London." 3. "G. N." 4. X crowned, with three small marks below.

Two pewter patens with feet, belonging to Foxton church, were made by the same maker as this one.†

* Nichols, Vol. iv., p. 155. † Page 182.

PEWTER DISH. Diam. $9\frac{1}{2}$ in.

Marks. 1. X crowned. 2. "London." 3. Between two pillars a lion rampant, with a name beginning "T. Be—" below. 4. "G. N."

TWO PEWTER DISHES. Diam. of each 9 in.

Marks. 1. X crowned. 2. A horse's jamb rising out of a crown. 3. "London." And four small marks, being, "S. D.;" a lion's head erased repeated twice; a lion's tail erased.

In 1662 the principal landowners here were **William Stareshmore** and **Roger Smith**, the father of Chief Baron **Smith**, the founder of the almshouse.*

LEIRE.

SILVER CUP. Weight 6.5 oz. Height $7\frac{5}{8}$ in. Diam. of the bowl $3\frac{1}{2}$ in.; of foot $3\frac{3}{8}$ in. Height of stem $4\frac{1}{2}$ in. Date *circa* 1581. (PLATE 26.)

The ancient hall marks on this cup are nearly obliterated. A capital Roman-D is the only portion visible; this may be either the annual letter for the year 1581, or the maker's mark; I am inclined to think it is the latter.

This cup has unusual features both in its shape and ornament; its bowl is nearly straight-sided, with a bell-shaped lip and a flat base. Running round it, close to the lip, is a band formed by two straps, with the zigzag line upon them, enclosing three rows of little horizontal strokes; from the lower part of this band, at equal distances apart, there project three large triangular ornamentations, pointing downwards; the inside of each of these triangles is filled with two wavy lines enclosing several vertical strokes. The stem is round and unusually long; from its middle, at which is a plain large round knob, it gradually swells out at both ends; at its junction with the bowl the edge of the stem is shaped into nine small lobes. The lower end of the stem swells out into a conical-shaped foot, which ends in a plain vertical band and a flat edge. Round the top of the foot is a narrow band of stroke ornament from which, pointing upwards, are three long triangular ornamentations, similar to those projecting from the band on the bowl. In 1867 a new lip, $\frac{1}{4}$ of an inch in width, was put on to the bowl, the inside being gilt; at the same time the flat edge to the foot was renewed, this latter being hall marked accordingly.

SILVER CUP. Weight 8.4 oz. Date 1858.

London hall marks.

This cup is a copy of the old one, both in size and shape; the same kind of ornament being engraved both on the bowl and foot. On the edge of its foot are stamped the hall marks for 1867. This cup was evidently in 1858, made in order to be used instead of the old one which was somewhat out of repair. In 1867 the old cup was repaired, and this new one seems, at the same time, to have had some alterations made in its foot, so as to make it exactly like the other in shape.

SILVER GILT DISH with a foot. Weight 9.7 oz. Diam. $8\frac{1}{2}$ in. Diam. of the foot $3\frac{3}{8}$ in. Height of foot $1\frac{1}{2}$ in. Date 1639. (PLATE 26.)

Hall marks. 1. Court hand B in a plain pointed shield, the upper half of the B, instead of being angular is an oval loop. 2. Lion passant. 3. Leopard's head crowned, each of the two last having an outer line round its outline. 4. F. L., a bird below, within a shaped shield.

This dish has a flat edge $1\frac{1}{4}$ in. wide, the middle part being sunk in a basin shape to the depth of 1 in. The foot is plain, round, and hollow, $1\frac{3}{4}$ in. thick at the top, swelling out a little lower down. Round the edge is engraved a band of conventional foliage, formed with a six petalled flower between two leaves, repeated twelve times; the background between the foliage is punctured. In the middle of the dish is an embossed Tudor rose, beaten out from the back; in the centre of which is a plate of silver with the vernicle engraved upon it; inserted probably at the time the dish was purchased, before which the rose had no doubt in its centre a round boss, with, possibly intersecting lines upon it. Underneath the paten, in fine letters much worn away, is: "*The gift of Ayliffe Greene, gent., to the parish of— 1650.*" Irrespective of the plate containing the vernicle, this paten is made of three pieces of metal, the flat edge, the basin-shaped part, and the foot. The gilding on all parts of it is a good deal worn away, and the outside edge is somewhat uneven, as if a little had, here and there, been taken off it.

SILVER PLATED PATEN with a foot. Diam. $6\frac{1}{2}$ in. Diam of the foot 3 in. Height of the foot $1\frac{3}{8}$ in.

This paten is perfectly plain, having in its centre the sacred monogram within a circle of glory.

SILVER PLATED FLAGON. Height 12 in. Diam. at the top $3\frac{1}{4}$ in.; at the foot $5\frac{3}{8}$ in.

This is a plain straight-sided flagon, narrowing to the top, at which is a spout.

PEWTER PLATE. Diam. $8\frac{1}{2}$ in.

Marks. 1. "Made in London." 2. A lion rampant within a triangle, above which is "W. Cooke" to the left, "London" to the right, an illegible word.

Archdeacon **Bonney** describes the church plate here thus: "handsome silver cup gilt within, silver plate, pewter plate." The silver plate was parted with when the additional pieces were given, or else before.

The modern silver cup, the ancient silver gilt dish, and two plated pieces were given to this church by the Rev. **Henry Kemp Richardson**, who was the son of **Samuel Richardson**, by **Mary**, daughter of Mr. **J. Durivale Kemp**, and was born on 5th Oct., 1807, at Prittlewell, Essex. He was educated under Dr. **Valpy**, at Reading, and at Trinity Coll. Camb.; in 1832 and 1833 he received deacon and priest's orders at the hands of his relative **Bishop Sumner**, of Winchester. In the latter year Mr. **Richardson** was appointed to the rectory of Leire, which he held for nearly fifty years, leaving behind him a well-earned reputation as a scholar, successful private tutor and conscientious parish priest; for twenty-five years he was rural dean of Guthlaxton II. He died suddenly on 10th Aug., 1882, and was buried in the chancel of this church. The Rev. **H. K. Richardson** was twice married, first on 29th July, 1833, at Harrold, co. Bedford, to **Fanny**, daughter of **James Taylor**, Esq., Member of the Council of Madras, which lady died on 23rd July, 1844, leaving several children, one of whom is the wife of her father's successor in this rectory; secondly, on 2nd Dec., 1847, to **Anne**, widow of **J. A. Arnold**, Esq.,

of Lutterworth, and second daughter of Baroness **Braye**, of Stanford; this lady died without issue on 22nd May, 1871.

LUTTERWORTH.

SILVER CUP. Weight 12.3 oz. Height $8\frac{5}{8}$ in. Diam. of bowl $4\frac{1}{8}$ in., of foot $3\frac{3}{4}$ in. Height of stem $4\frac{1}{8}$ in. Date **1798**.

Hall marks. 1. Head of King **George III.** 2. Capital Roman C. 3. Leopard's head crowned. 4. Lion passant. No maker's mark.

The bowl of this cup is something in the shape of an acorn, the upper part rising out of a spherical cup; the upper part being straight-sided, with a bell-shaped lip. Round the bowl, not far from the edge, is an appliqué band of laurel leaves. In front is the sacred monogram, with a cross above and three nails below, within a circle of glory. Round the lower part of the bowl there are acanthus leaves embossed, placed vertically at some little distance apart. The stem is somewhat baluster in shape. Round the edge of the foot there is an embossed band of acanthus-leaved ornament.

SILVER CUP. Weight 14.7 oz. Date **1824**.

London hall marks.

This cup is the same in shape and design as the first. It is of more weight than the other because the stem and some other parts of it are slightly thicker.

SILVER PATEN with foot. Weight 11.5 oz. Diam. $7\frac{1}{2}$ in. Diam. of foot $3\frac{1}{4}$ in. Height of foot $2\frac{3}{8}$ in. Date **1840**.

London hall marks.

This paten has the sacred monogram in the centre, and a fleur-de-lis ornamentation round the edge.

SILVER DISH. Weight 10.3 oz. Diam. $9\frac{1}{8}$ in. Date **1792**.

Hall marks. 1. Head of King **George III.** 2. Small Roman R. 3. Leopard's head crowned. 4. Lion passant. 5. I. R. in an oblong.

This dish is quite plain in shape.

SILVER SPOON. Weight 1.3 oz. Length $7\frac{3}{4}$ in. Date **1712**.

Hall marks. 1. Court hand R. 2. Lion's head erased. 3. Britannia. 4. A. R. Mark perhaps of *Andrew Archer*.

The bowl of the spoon is perforated, having a design in conventional foliage.

SILVER FLAGON. Weight 45.8 oz. Height $10\frac{1}{2}$ in. Diam. of top $3\frac{3}{8}$ in., of foot $6\frac{1}{2}$ in. Date **1763**.

Hall Marks. 1. Capital old English H in plain shield. 2. Leopard's head crowned in plain shield. 3. Lion passant in an oblong. 4. F. C. in an oblong: Mark of *Francis Crump*.

This flagon is straight-sided in shape, narrowing towards the top, with a spout. The lid has a round top with an acanthus-leaved ornament on it, and an appliqué band of laurel leaves round its edge; a similar wreath runs round the drum near the top; and round the lower part is a row of acanthus leaves repoussé placed vertically, and another band of acanthus leaves round the foot. In front is: "*This communion service was presented to the parish of Lutterworth by Maria Hawes Ware, as a thank-offering for God's mercies to a beloved son, who died in faith and hope June 6th, 1840.*"

FIVE PEWTER DISHES. Diam. of each 9 $\frac{3}{4}$ in. Date 1675.

Marks. 1. On one side of edge, each in a plain shield: (a) Lion rampant. (b) A crown. (c) An anchor. (d) T. K. with a cross below. 2. On opposite edge, a capital Roman L and C, each in a shaped shield; standing for "Lutterworth Church." 3. Underneath the dish: an anchor crowned with the date 1675 across it; above the anchor "Tho. King," below "London."

These five pewter dishes were until a few years ago, used for collecting plates.

There was formerly in Lutterworth church a board headed: "An account of benefactions to this church and parish, taken anno domini 1708." The first benefaction mentioned being this: "To the church"—"A long hadley and piece of furzy ground in the middle field, and a meadow in the street field; a little silver gilt chalice, and a large silver gilt chalice and cover, given by **Gabriel Abbot**, of Lutterworth, mercer."*

The following is a copy of Archdeacon **Bonney's** description of the plate belonging to this church in 1832. "Two silver cups, gilt, one of them with this inscription: "*The gift of Gabriell Abbott, of Lutterworth.*" The other old and handsome, with an ancient border. Two patens, one inscribed: "*Poculum Salutis;*" the other small and gilt. A silver plate. A silver spoon. A pewter basin. Five pewter plates."

The silver plate and spoon and the five pewter plates still remain in the possession of this church. Both the old silver gilt cups (the older one being probably Elizabethan) and patens were given over to Mrs. **Ware**, to help her to pay for the two silver cups, the paten and flagon, which she gave to this church in 1840. The silversmith who took the ancient pieces either melted them down or sold them as antiques.

There was also formerly here a pewter flagon provided in accordance with this clause in the will of **Margaret Abbott**, widow, made 10th Jan., 1634, and proved in Leicester 26th May, 1635: "*I give and bequeath unto the parish church of Lutterworth, one flagon of pewter, of two quartes, for the communion, to be bought by my excutor and delivered to the churchwardens for the time being, for the use of the church aforesaid.*"

She desired to be buried in the churchyard of Lutterworth, and left legacies to **Joanne Bradgate**, daughter of "my son" **Richard Bradgate**, to **Joanne's** sister, **Mary Bradgate**, now wife of **Thomas Garrat**, to "daughter" **Elizabeth Neale's** children, to "my son" **Robert Bradgate's** children; all other goods to son and sole executor **Gabriell Abbott**.

The larger cup formerly here with its cover inscribed "*Poculum Salutis*" was the bequest of **Gabriel Abbott**, made in his will dated 17th July, 1635, and proved P.C.C. 29th Sept. 1635, in these words: "*I give £10 to buy a communion cupp for the use of my neighbours of Lutterworth.*"

He desired to be buried in Lutterworth church, and left £5 to poor of that place; £5 to poor of Bosworth; to his two daughters £200 and "money that is to be paid out of my land

* See *Nichols*, Vol. iv., p. 258.

at Bosworth as by deed may appear;" said daughters to be provided for by wife till they are 18; to wife all else and, "right in my house which I had by way of mortgage in Lutterworth," she sole executrix. No names of wife or daughters given.*

The donor of the main part of the present service was **Maria Hawes**, eldest daughter of Sir **John Gurney**, Knt., one of the Barons of the Exchequer, by his wife **Maria**, daughter of Dr. **William Hawes**, a London Physician, and one of the founders of the Royal Humane Society, and was born on 27th April, 1799. She married at Streatham, on 21st Nov., 1820, Mr. **Robert Ware**, of Battersea, † a West India Merchant, the son of **James Ware**, the celebrated oculist. During their short married life Mr. and Mrs. **Ware** resided at Balham Hill, Surrey; Mr. **Ware** died at Ramsgate, on 6th July, 1824, aged 30. ‡ After her husband's death Mrs. **Ware**, with her two sons, came to live at Lutterworth, in order to be with her eldest brother the Rev. **John Hampden Gurney**, who was for some years the very excellent curate in charge of this parish. § Here Mrs. **Ware** lost both her sons; the youngest, **Maitland Gurney**, dying on 25th Aug., 1831, aged 8; the eldest, **Frederick Robert**, commemorated in the inscription on his mother's gift, on 6th June, 1840, aged 18; a tablet to their memory was placed by their mother in the North aisle of this church. Soon after the death of her eldest son, both she and her brother left Lutterworth. Mrs. **Ware** died on the 29th July, 1863, and was buried in the **Gurney** vault in Highgate cemetery, on the monument over which is a short inscription to her memory.

With respect to the gift of plate made by Mrs. **Ware**, it may be noticed that the paten only was a new piece of plate; the other three pieces being all of different dates. Possibly the two cups and the flagon were originally secular pieces of plate belonging to one set, having been made to match one another at different times.

SAPCOTE.

(a)

SILVER CUP. Weight 13.4 oz. Height 8 in. Diam. of the bowl 4½ in.; of the foot 3¾ in. Height of the stem 3½ in. Date 1799.

Hall marks. 1. Capital Roman D in a square shield. 2. Head of King George III. 3. Lion passant. 4. Leopard's head crowned. 5. S. H. in an oblong.

This is a plain cup with a straight-sided concave bowl, rounded in the lower part. Its stem is round, swelling into a knob with a bevelled edge in the middle. The stem stands on a plain round foot. On one side of the bowl is the sacred monogram, with a cross above and three nails below, within a circle of glory; and on the other "*Dei Gloria, et servitio altaris sui in parochiali ecclesia de Sapcote in comitat Leicestrens me dicabat Maria Frewen. Anno Domini 1800.*"

* Lutterworth Parish Registers begin in 1653. † Parish Register. ‡ *Genl. Mag.*, Vol. xciv., pt. 2., p. 94
§ Afterwards rector of St. Mary's, Bryanstone Square, and Prebendary of St. Paul's. *Ob.*, 8th March, 1862.

SILVER PATEN with a foot. Weight 7.9 oz. Diam. 6 in. Diam. of the foot $2\frac{1}{4}$ in. Height of the foot $1\frac{3}{8}$ in. Date 1799.

Hall marks as on cup.

This is a plain shaped paten with a raised moulding round its edge. In its centre and also on its foot is the sacred monogram with a cross and three nails within a circle of glory. Round the monogram in the centre is the same inscription as that on the cup.

SILVER PLATE. Weight 11.9 oz. Diam. $8\frac{1}{2}$ in. Date 1799.

Hall marks as on cup.

This plate has a flat edge, round the outside of which is a raised moulding. In the centre on a plain round boss, is the sacred monogram as on the paten, round which also is the same inscription.

SILVER FLAGON. Weight 34.2 oz. Height $11\frac{3}{4}$ in. Diam. at the top 3 in.; at the foot $4\frac{1}{8}$ in. Date 1799.

Hall marks as on cup.

This is a tall jug-shaped flagon, the main part of it being shaped like a pear, it stands upon a short round stem swelling into a plain round foot. At the top is a wide shallow spout, over which falls a lid with a rounded top surmounted by an ornamental knob. The handle to the flagon is long, narrow, and reeded. In front is the sacred monogram, with a cross and three nails in a circle of glory, dividing in half the inscription mentioned above.

(b)

SILVER CUP. Weight 12.5 oz. Date 1837.

London hall marks.

This cup is the same in shape and size as the first. On one side of the bowl is the sacred monogram arranged as before; and on the other the same inscription as that on the first cup to the end of "*dicabat*," after which comes "*Eleanor Frewen Turner, Anno Domini, 1838*."

In the terrier of 1709 we find the church plate of this parish mentioned thus, "A pewter flagon, a silver cup and cover, the weight we know not."

On the last day of the year 1765 this parish suffered the loss of its communion plate which was stolen out of the church. A silver plated cup was then bought for £2 19s. od., towards which Mrs. Turner gave £1 1s., and a flagon, two plates and a basin for 14s.; which were used from that time till the year 1800, when Miss Mary Frewen gave the silver service mentioned above.

(a)

This latter lady was the eldest daughter of the Rev. Thomas Frewen, who sprang from a younger branch of the Frewens of Northiam, co. Sussex, and was rector of this parish from 1732 to 1778, by Esther, daughter of Benjamin Simkin, of Cropston in Thurcaston, co. Leicester, and was born in 1753. Her father succeeded, upon the death of his cousin Laton Frewen in 1777, to the Turner estates in Sapcote and Cold Overton in this county, and to the Frewen property in Sussex, Kent, and Middlesex, and took the name of Turner.* In addition to this communion plate Miss Mary Frewen presented in 1793 the clock to this church, which was partly reconstructed in

* For some account of these two families see *History of Sapcote*, by H. Whitley, M.A., 1853, formerly curate here.

1852. This lady died unmarried at Brickwall, Northiam, on 7th Dec., 1811, and was buried in the **Frewen** chapel in Northiam church.

In which chapel is a plain mural monument of marble to her memory, the inscription on which includes these words; "*She lived sincerely valued and loved by her friends, for kindness of heart, and a peculiar cheerfulness that gave an exhilarating influence to her society. Her charity was habitually secret and unobtrusive, but her munificent donations to the churches of Cold Overton and Sapcote are public monuments of her pious liberality.*"

(b)

Eleanor Frewen Turner, the donor of the second silver cup, was the daughter and co-heiress of **Charles Clarke**, Esq., of Westminster, by **Elizabeth**, his second wife, only child of Capt. **David Kay**, R.N., and was born on 16th Jan., 1786. She married in 1808, **John Frewen Turner**, Esq., the brother of the lady who gave the first mentioned service. At the death of his father in 1791, Mr. **John Frewen** took the name and arms of **Turner**, as his father had done before him, since he then inherited the **Turner** estates together with those of **Frewen**. This gentleman, who was high sheriff of Leicestershire in 1791 and M.P. for Athlone from 1807 to 1812, died on 1st Feb., 1829, aged 73. Mrs. **Frewen Turner** survived her husband 50 years; living during most of that time at Cold Overton; at which place she died on 19th March, 1879, at the age of 93 years.

At the West end of the South aisle of Cold Overton church, amongst other monuments to the **Frewen** family, is one on the North side to this lady, the inscription on which concludes with these words. "*Her constant acts of kindness and liberality caused her to be endeared to many in this neighbourhood, among whom she spent her unusually long life. 'The memory of the just is blessed.'* Prov. x. 7."

In the same year in which she gave this silver cup to Sapcote church, Mrs. **Frewen Turner** built and endowed Trinity church in Hinckley; the site being given by her son, **Thomas Frewen**, Esq., father of **Edward Frewen**, Esq., the present representative of the family.

It will be noticed that the inscription on this communion service was copied from Mr. **Turner's** gift to Cold Overton.*

SHARNFORD.

SILVER CUP WITH A COVER PATEN. Weight of the cup 6.7 oz. Height $6\frac{1}{8}$ in. Diam. of the bowl $3\frac{1}{2}$ in.; of the foot 3 in. Height of the stem $2\frac{3}{4}$ in. Date 1609. (PLATE 27.)

No hall marks.

Here we have an example of a late cup and cover of Elizabethan design. The bowl of the cup is shaped into an inverted truncated cone slightly concave, with a flat projecting base. Round its upper part is a band of stroke ornament divided into four parts by hour-glass curves.

At the top of the stem is a short neck, below which is a disk $1\frac{1}{2}$ in. wide, divided into sixteen parts by radii, the upper surface of every other part being ornamented with zigzag lines. From the disk, the stem swells out gradually, finishing in a vertical edge reeded. Round the top of the foot, which is a little higher than usual, is a band of stroke ornament divided into four parts by hour-glass curves. The foot ends in the usual vertical and flat edges, the reed ornament running round the former.

SILVER COVER PATEN with a foot. Weight 1.2 oz. Diam. $3\frac{3}{4}$ in. Diam. of the foot $1\frac{1}{4}$ in. Height of the foot $\frac{3}{8}$ in. Date 1609. (PLATE 27.)

No hall marks.

• This paten has a flat edge $\frac{1}{4}$ in. wide, on which is the usual rim. The middle part is sunk in a rounded flat. The foot is a disk attached to the paten by a short thick stem. Round the top of the paten is a band of stroke ornament like that round the bowl of the cup. On the foot is "*Sharnford, T. H. T. B. 1609.*" In the year 1874, this cup and its cover were regilt inside; the dints in both were beaten out and a piece of new metal was fastened on to the bottom of the bowl of the cup.

SILVER PATEN with a foot. Weight 5.7 oz. Diam. $5\frac{1}{2}$ in. Diam. of the foot $2\frac{1}{4}$ in. Height of the foot $1\frac{1}{4}$ in. Date 1726.

Hall marks. 1. Harp crowned within an outline shaped as the stamp. 2. Capital old English F in a pointed shield. 3. I. M. rather indistinct. Dublin hall marks.*

This paten, which once belonged to some other church, is flat and perfectly plain, with a hollow foot. In the centre is the sacred monogram with a cross above and three nails below, within a circle of glory. Underneath the paten are some small rough places which look as if they may be the filling up of an old inscription.

SILVER PLATE. Weight 7.1 oz. Diam. 7 in. Date 1851.

London hall marks.

This is a perfectly plain plate, having in its centre the sacred monogram with a cross and three nails within a circle of glory.

SILVER PLATED FLAGON. Height $10\frac{1}{4}$ in. Diam. at the top 3 in.; at the foot $4\frac{3}{4}$ in.

This is a straight-sided flagon narrowing to the top, at which is a spout. Round the drum are diagonal bands of grapes and vine leaves. The lid is surmounted by a double cross.

In the terrier of 1709 these church goods are mentioned in addition to the silver cup and cover; "Two pewter flagons, one with 'G. B. L,' the other no mark; a pewter plate with 'G. B. L.,' a basin with 'R. D.,' an old communion table-cloth '*Ex dono R. D. 1651;*' a green communion table-cloth, broad-cloth 'R. L. A. D. 1666.'"

The initials on the cover paten are probably those of the churchwardens in 1609.

Both the silver paten and plate together with the plated flagon were presented to this parish by the present rector, the Rev. **Henry Lacon Watson**, rural dean of this deanery and honorary Canon of Peterborough

* Vide *Old English Plate*, by W. J. Cripps, F.S.A., 3rd Edit., p p. 138 and 378.

Cathedral. Canon **Watson**, who was appointed to this living in 1850, has long taken a most helpful interest in the work of the church within this diocese.

SHAWELL.

SILVER CUP. Weight 9.3 oz. Height $6\frac{7}{8}$ in. Diam. of bowl and of foot $3\frac{7}{8}$ in. Height of stem $3\frac{1}{8}$ in. Date **1662**. (PLATE 25.)

Hall marks. 1. Capital old English E in plain shield. 2. Lion passant. 3. Leopard's head crowned, each of the last two having a line following its outline. 4. I. C. with a mullet below within a heart-shaped shield. The bowl of this cup is straight-sided. The stem is quite plain, without a knob, swelling out into a plain foot. On the bowl is "*Ecclesæ de Shawell*." Underneath the foot is the lion passant and also this weight 9 oz. 6 dwts.

SILVER COVER PATEN with a foot. Weight 3.4 oz. Diam. $4\frac{3}{8}$ in. Diam. of foot $1\frac{7}{8}$ in. Height of foot $\frac{7}{8}$ in. Date **1710**. (PLATE 25.)

Hall marks. 1. Court hand P. 2. Lion's head erased. 3. Britannia. 4. L. O. with mullet below and two roundels above; probably mark of *Robert Lovell*.

This paten which is quite plain in shape was made to fit the cup as a cover. In the centre is; "*Ecclesie de Shawell ex dono Edwardi Sherrier etc.*"* The maker's mark is repeated, underneath, and there is this weight, 3 oz. 8 dwts.

SILVER DISH with a foot. Weight 13.2 oz. Diam. $8\frac{5}{8}$ in. Diam. of foot $3\frac{1}{8}$ in. Height of foot $1\frac{7}{8}$ in. Date **1708**.

Hall marks. 1. Court hand N. 2, 3, and 4, as on cover paten.

This dish, which is quite plain in shape, has this inscription on it. "*Ecclesie de Shawell ex dono Edwardi Sherrier Rectr ibid in memoria trium sororum Elner Mariæ et Susannæ defunct, Anno 1709.*"

SILVER PLATED FLAGON. Height $8\frac{1}{2}$ in.

Underneath is this inscription. "*Ecclesie de Shawell, D.D. Maynard Anna Blencowe.*" The donor of this flagon was the wife of the Rev. **William Multon Blencowe**, M.A., rector of this parish from 1834 to 1841.

PEWTER BASIN. Diam. 7 in. Date *circa* **1685**.

No marks.

This is a plain round basin with an edge $\frac{1}{2}$ in. wide round the top at right angles to its side. Some of the edge has been broken off. On that part which remains is: "*John Parks Rectr of Shawell*," with a cross between each word. This basin was formerly placed inside the font and used for baptisms.

PEWTER FLAGON. Height $10\frac{3}{4}$ in. Diam. of top $4\frac{1}{4}$ in.; of foot $5\frac{3}{8}$ in.

Marks. Each in a shaped shield; 1. W. S. 2. Leopard's head crowned. 3 and 4 indistinct.

This flagon is straight-sided, narrowing a little towards the top. The lid has a flat top, the rivet belonging to its hinge being missing. In front is: "*The gift of Mr. John Parkes Rector of this church, 1685.*"

* The "etc." represents the remaining part of the inscription, which has been engraved in full on the dish mentioned next.

Attached to the well kept registers of this parish is a terrier, made in the incumbency of Mr. **Sherrier**; in which two pewter flagons are mentioned. In a later terrier made in 1821, one flagon only is named, the other having disappeared meanwhile. With this exception, and with the exception of the modern plated flagon, the church plate belonging to this parish is just the same now, as it was when those two terriers were made.

The Rev. **William Astell** was rector of this parish when the silver cup was made: he was buried here on 4th July, 1671.

The Rev. **John Parkes**, the donor of the two pewter pieces was the son of **Christopher Parkes** of the city of Oxford, and matriculated at the age of 15, into Oriel Coll., Oxford, on 8th May, 1635: from whence he took his B.A. on 26th May, 1638, and M.A. on 20th May, 1641. On 3rd May, 1644, he was appointed by the Visitor a fellow of Lincoln Coll.* Mr. **Parkes** vacated his fellowship in 1649, upon being presented to the rectory of Eydon, Northants.† He was created B.D. on 28th Feb., 1660-1, and on 30th Nov., 1671, was instituted to the rectory of Shawell.‡ He was allowed to hold both livings and resided at Eydon, where he died in 1692, aged 73, and was buried in the chancel, where there was once a slab to his memory, the inscription on which spoke of him thus; "*Ecclesie Anglicanæ assertor fuit strenuus, Dei servus, regis subditus, quos semper coluit fidelis.*"§ The Rev. **J. Parkes** was thrice married, and had by his first wife **Elizabeth**, a son, **Paul**, baptized at Eydon on 17th May, 1655, and another, **John**, baptized on 18th Dec., 1656, who matriculated into St. Edmund Hall, Oxford, on 10th July, 1672. His second wife was **Hester**, second daughter of Mr. **Ambrose Holbech**, of Mollington, by his wife **Joan**, which lady died on 20th Aug. and was buried at Eydon on 22nd, 1681. His third wife **Elizabeth**, survived for some years and was buried at Eydon, on 5th Aug., 1724.¶

The Rev. **Edward Sherrier**, the donor of the silver cover paten and dish, was of East Harting, Sussex, and matriculated at the age of 17 into Trinity Coll., Oxford, on 23rd Nov., 1677;¶ from whence he took his B.A. degree in 1681, and M.A. from St. Mary Hall in 1684. He was ordained priest by the Bishop of Lincoln on 24th Feb., 1683, and on the same day instituted to the rectory of Addington, Bucks. On 5th May, 1696, he was instituted to the rectory of Shawell on the presentation of **William** and

* Communicated by Rev. A. Clark, fellow of Lincoln. † "Mr. John Parkes was presented minister of Eylon by ye Lord Keeper of ye Greate Seale of England, Dec. ye 26, 1649." "Mr. John Parkes tooke possession of ye sayd Parsonage March 25, 1650, there being present most of ye sayd Parish." Parish Register. ‡ Bishop of Lincoln's registers. § Bridges' *Hist. of Northants*, Vol. i., p. 123. ¶ Parish register; in which the name is spelt Sparkes, as it is at times in Oxford registers. ¶ University Register. He was probably the son of Nicholas "Nicholas, son of Nicholas Sherrier, bap. 13th Feb., 1661." "Richard Scardefield and Mary Sherrier marr. 17 Jan., 1705-6." Harting parish register.

Mary;* and here he resided till his death; he was buried at Shawell on 2nd March, 1731.† Mr. **Sherrier** was twice married and had by his first wife, **Dorothy**, the three children in whose memory he gave these pieces of plate; **Elner** and **Susannah** were buried on 5th March, 1710, and **Mary** 18 days later; their mother was buried here on 13th March, 1722.† Mr. **Sherrier** married secondly, at Hillmorton, co. Warwick, on 5th May, 1724, **Mercy Sandys**, of Hillmorton,‡ by whom he had two daughters born to him, **Mary**, baptized at Shawell on 17th Sep., 1725, and **Ann**, baptized on 2nd and buried 15th March, 1728.† His only surviving child, **Mary**, and his wife **Mercy**, outlived him only for a few months.

On 17th April, 1732, administration of the goods of **Mercy Sherrier**, late of Shawell, widow, was granted in the P.C.C. to her spinster sister **Penelope Sandys**; **John Sandys**, Esq., father of deceased, first renouncing all claim.

Mr. **Sherrier's** name will live in these parts in the Free-school at Lutterworth, which gained the benefit of nearly the whole of his estate owing to the death of his wife and daughter.

In his will, made 25th Jan., 1730, and proved in Leicester on 15th Oct., 1731, he left £5 to the poor of Shawell, and £1 to the poor of every parish adjoining; to rectors for time being of Lutterworth, Shawell and Misterton £200 in trust, the interest to be spent in paying at the Free School, Lutterworth for 5 poor boys, one to be apprenticed each year, overplus to be spent in giving Bibles, Prayer Books, and The Whole Duty of Man, to the most deserving of such children on leaving school, and in any other charitable work trustees think fit; the children to be taught reading, writing, and arithmetic, and especially Church Catechism, and to behave decently in church. To daughter **Mary** and her heirs, his estate in Churchover, co. Warwick, but the rents to his wife for life. If his daughter dies before 21, after wife's death, then that estate to seven trustees, they out of the rents to build a school-house in Lutterworth near church, keep same in good repair and provide schoolmaster to teach as many poor children as trustees think fit. If his daughter dies before 21, then the above £200 to go to building the same school; and also in that case his real estate in Shawell to pass to the same trustees, they to spend the rents as follows: £2 10s. a year for schoolmistress of Shawell to be chosen by rector; children to be brought to church and taught to kneel reverently; 1s. a week each to six alms-men of Shawell§ provided they attend daily prayers in school and services in church; out of the rents of the Shawell estate the trustees to erect an alms-house next school in Lutterworth, maintaining so many poor men of that town as they think fit; rest of Shawell rents to go to Lutterworth school. Wife residuary legatee and sole executrix.¶

In 1732 Mr. **Sherrier's** trustees bought a house in Lutterworth for the schoolmaster next the schoolroom, which belonged to the town estate. Under a new scheme drawn up in 1874, various charities were amalgamated and entirely new elementary schools built for boys, girls and infants, on glebe land given by the rector. Under the same scheme buildings were erected in 1880 for a middle class school for boys, both boarders and day scholars. Provision has also been made under the scheme for the higher education of girls.

* Bishop of Lincoln's register. † Parish Register. ‡ Parish Register. § Almshouse founded by John Elkington. ¶ For full account of Mr. Sherrier's school and alms-house, see *Report of Charity Commissioners*. Vol. xvii. p. 133.

SWINFORD.

SILVER CUP. Weight 14.2 oz. Height $8\frac{3}{4}$ in. Diam. of bowl and of foot $4\frac{1}{2}$ in. Height of stem $4\frac{1}{4}$ in. Date 1752.

Hall marks. 1. Small Roman R. 2. Leopard's head crowned. 3. Lion passant, in shaped oblong. 4. T. R. G. C. in a quatrefoil; the mark of *Richard Gurney & Co.*

This cup has a straight-sided bowl, with a bell-shaped lip and plain stem, with a small moulding for a knob. On the bowl is the sacred monogram with a cross above and three nails below, within a circle of glory; underneath is the date "1752," and this inscription in script letters; "*Thos Cave Baronettus in Usum Ecclesie Parochialis de Swinford in Agro Leicestriensi: Gratissime Dono Dedit.*"

SILVER PATEN. Weight 13.6 oz. Diam. $8\frac{7}{8}$ in. Date 1739.

Hall marks. 1. Small Roman D in a plain shield. 2, 3, and 4 as on cup.

This paten has all the appearance of having been originally a dinner plate. In the centre is the sacred monogram and round the edge the same inscription as that on the cup.

SILVER FLAGON. Weight 36.3 oz. Height $10\frac{7}{8}$ in. Diam. of top $3\frac{1}{2}$ in.; of foot $6\frac{1}{4}$ in. Date 1752.

Hall marks as on the cup.

In shape this is a straight-sided flagon narrowing towards the top; with a round top to the lid. In front is the sacred monogram and the same inscription as that on the cup.

PEWTER DISH. Diam. $9\frac{3}{8}$ in.

Marks. 1. X crowned. 2. A horse's jamb rising out of a crown. 3. London. 4. Pechevron dancetté three lions' heads erased. 5. On a fesse three escalops. 6. Lion's head erased. 7. J. D.

Sir **Thomas Cave** was a gentleman well known in the counties of Leicester and Northampton, in the last century. He was the representative of the ancient family seated at Stanford, co. Northants, in the 15th century, being the second son of Sir **Thomas Cave**, Bart., by **Margaret**, youngest daughter of **John Verney**, Viscount **Fermanagh**, and was born on 27th May, and baptized on 4th June, 1712.* On the death of his elder brother Sir **Verney Cave**, unmarried, in 1734, Sir **Thomas** succeeded as 5th Bart., and inherited the family estates of Stanford and Swinford. From 1741 to 1747 he was M.P. for Leicestershire, and was again elected in 1762, retaining his seat till 1774. Sir **Thomas**, living and owning land on the borders of Northampton and Leicestershire took the greatest interest in the affairs of both counties, especially in their topography: each shire owes its county history, in part at any rate, to his labours, for he was chairman of the committee appointed to supervise the publication of *Bridges' Hist. of Northants*,† while his collection of MSS. relating to Leicestershire was the foundation

* Parish Register. *Associated Soc. Reports*. Vol. xvii., pt. 1. p. 113.

† Vol. i, Preface.

upon which *Nichols'* work was laid.* Sir **Thomas Cave** who was created a D.C.L. in 1756 by Oxford University, died on 7th Aug., 1778, and was buried at Stanford on the 17th. He married in Nov., 1735, **Elizabeth**, only child and heiress of Dr. **Griffith Davies**, of Theddingworth,† which lady bore him several children and was buried at Stanford on 6th May, 1759.

Through want of male issue the **Cave** estates passed eventually to the granddaughter of Sir **Thomas**, **Sarah** wife of **Henry Otway**, of Castle Otway, co. Tipperary, which lady after the death of her husband resumed the name of **Cave**, and in 1839 had the Barony of **Braye** terminated in her favour. At her death in 1862, the Barony fell into abeyance between her four daughters, and co-heirs; the eldest dying unmarried, and the second‡ and third without issue, the title has passed to the youngest daughter's youngest son, the present Lord **Braye**. The Baronetcy at the death in 1810, of the Rev. Sir **Charles Cave**, 8th Bart., passed to a descendant of Sir **Roger**, 2nd Bart.; the present holder of the title being Sir **M. C. Browne Cave**, Bart., of Stretton, co. Derby.

The arms of **Cave** are *Azure, fretty Argent*. Crest: *a greyhound courant Sable*; on a scroll out of the mouth the word *Gardez*.

The late Baroness **Braye** placed on the South wall of the chancel of Stanford church a monument to her grandfather Sir **Thomas Cave**, in the upper part of which is a medallion bearing his bust.

* Vol. i Preface and Vol. iii, p. 5.

† *Vide* page 196.

‡ *Vide* Leire, page 345



Then took he himself the holy vessel, and came to
Galabad, and he knuckled down and there he received his
Saviour, and after him so received all his fellows; and
they thought it so sweet that it was marvellous to tell.

GUTHLAXTON THIRD DEANERY.

ARNESBY.
ASHBY MAGNA.
BRUNTINGTHORPE.
FOSTON.
GILMORTON.

KILWORTH NORTH.
KILWORTH SOUTH.
KIMCOTE.
KNAPTOFT.
MOWSLEY.
SHEARBY.

MISTERTON.
PEATLING PARVA.
WILLOUGHBY
WATERLESS.
PEATLING MAGNA.



ARNESBY.

SILVER CUP. Weight 5.1 oz. Height $5\frac{3}{4}$ in. Diam. of bowl $2\frac{3}{8}$ in.; of foot $2\frac{3}{4}$ in. Height of stem $2\frac{1}{2}$ in. Date 1568. (PLATE 28.)

Hall marks. 1. Small black-letter L in a pointed shield. 2. Lion passant in a plain oblong. 3. Leopard's head crowned, with an outside line following its outline. 4. Stag's head in a square-shaped stamp.

The bowl of this cup is in shape an inverted truncated cone. Round its lip is a band of foliage, immediately under which is a small raised moulding. The stem is a plain round narrow one without a knob, which may perhaps have once been there; it swells a little towards its two ends, round each of which is a band of lozenge ornament. The foot has the egg and tongue ornament round its edge.

SILVER PATEN with a foot. Weight 4.7 oz. Diam. $5\frac{5}{8}$ in. Diam. of foot $2\frac{1}{2}$ in. Height of foot $\frac{5}{8}$ in. Date *circa* 1690. (PLATE 28.)

One mark only, viz., the maker's; S. N., with a cinquefoil and two pellets below, within a plain shield.

This paten has a flat edge, the middle part being sunk rather deeply. The foot is plain and flat, swelling into a short narrow stem. Underneath the foot has been scratched "John Blackwell."

PEWTER FLAGON. Height $10\frac{1}{4}$ in. Diam. at top $4\frac{3}{8}$ in.; at foot $6\frac{1}{4}$ in.

Marks. On the lid four lions passant in as many small oblongs. On the purchase is a mark possibly meant for an A: it is the letter V with a line placed horizontally across the point.

This flagon is straight-sided in shape, narrowing a little towards the top, having a flat lid.

PEWTER PLATE. Diam. $8\frac{1}{2}$ in.

Mark. A crown with R. C. below: the C being smaller than the R.

This plate has a raised narrow edge. Its upper surface is covered with an engraving of a conventional character, the design being rose sprays with a bird in the middle. Underneath the plate has been scratched "*Presented to the parish by Mrs. Tebbs, Arnesby, Apr 9th, 1841.*"

ASHBY MAGNA.

SILVER CUP AND COVER PATEN. Weight of cup 6.2 oz. Height 6 in. Diam. of the bowl $3\frac{5}{8}$ in.; of the foot $3\frac{1}{2}$ in. Height of stem $2\frac{3}{4}$ in. Date 1618. (PLATE 27.)

No hall marks.

Here is a late example of a cup of Elizabethan character; it has a bowl shaped into an inverted truncated cone, slightly concave, having a flat projecting base. Round the bowl is a band of foliage divided into four parts by hour-glass curves, the lines of which are very sharp and distinct. The stem is evenly balanced with a small moulding for a knob, from whence it swells straight out towards each end. The foot is of the usual shape with reeds round its edge. This cup resembles in every point those marked with the "rose," except in its stem having straight, and not curved sides.

SILVER COVER PATEN with a foot. Weight 2.7 oz. Diam. $4\frac{1}{4}$ in. Diam. of the foot $1\frac{1}{2}$ in. Height of foot $\frac{3}{4}$ in. Date 1618. (PLATE 27.)

No hall marks.

This paten, which is sunk rather deeply, has round its top a band of stroke ornament divided into four parts by hour-glass curves. The foot is a disk, attached to the paten by a plain round stem. On the foot is engraved the date "1618." The paten fits on to the cup both ways.

SILVER CUP. Weight 13.6 oz. Height $7\frac{3}{4}$ in. Diam. of the bowl $3\frac{7}{8}$ in.; of the foot $5\frac{1}{8}$ in. Date 1866.

London hall marks.

This cup has a globular bowl, and hexagonal stem, knob, and foot. The foot is shaped into six lobes, the sacred monogram being engraved on one. Underneath the foot is "*In honour of God and in memory of the Rev. Edward Gibson, M.A., Vicar of this parish; this chalice was presented to Ashby Magna Church by his widow A.D. 1866.*"

SILVER PATEN. Weight 4.3 oz. Diam. $6\frac{3}{8}$ in. Date 1866.

This paten is sunk in six lobes, having the sacred monogram in its centre. Round its edge is: "*Lord, evermore give us this bread,*" and underneath is the same inscription as that on the cup; "paten" instead of "chalice."

SILVER FLAGON. Weight 23.4 oz. Height 12 in. Diam. at the top $2\frac{1}{2}$ in.; at the foot 4 in. Date 1866.

This is a jug-shaped flagon, with an ornamental band round its neck, and round the middle "*Glory be to God on high.*" Each end of the handle terminates in a fleur-de-lis. Under the foot is the same inscription as on the cup; "flagon" instead of "chalice."

PEWTER PLATE. Diam. $9\frac{1}{4}$ in. Date 1697.

Marks. 1. On the edge in four small stamps (a) Leopard's head. (b) Lion rampant. (c) Lion's head erased. (d) G. S. 2. Underneath the plate: Rose crowned, rest illegible. 3. A lily rising out of a plough. 4. "Ashby Magna, 1697," scratched.

Upon the edge of the plate is engraved; "*John Crowder and Thos. Beale, Churchwardens, 1832.*" These names were no doubt put on to this plate at the time when the next was bought.

PEWTER PLATE. Diam. $9\frac{3}{4}$ in.

No marks.

Round the edge of this plate is; "*Jno. Crowder and Thos. Beale, Churchwardens, 1832.*"

This plate is evidently of the same date as the inscription.

TWO BRITANNIA METAL BASINS. Diam. of each $10\frac{1}{2}$ in.

Upon the edge of each is; "*Ashby Magna. Wm. Sammons and Jno. Beale, Churchwardens, 1856.*"

PEWTER FLAGON. Height 7 in. Diam. at the top 4 in.; at the foot $4\frac{1}{4}$ in.

Marks. 1. Sun. 2. X. 3. B and V. 4. Eagle's head erased; all small.

This is a copy of the small silver tankards made in the latter half of the last century. Its drum is ogee-shaped. It has a plain round foot, and a round top to its lid.

In an undated terrier signed by **William Cotton**, and probably made in 1709, the church plate here is said to be: "A silver bowl, a pewter flagon." In the terriers of 1724 and 1745 it is thus named: "A communion cup, silver, with a pewter plate and flagon."

The Rev. **Edward Gibson**, to whose memory the modern silver communion service was given to this church by his widow, was buried in Ashby churchyard. Over his grave is a recumbent monument of freestone, with a cross on the top, thus inscribed; "*Edward Gibson, M.A., S. John's Coll. Cantab., 15 years vicar of this parish, died Sept. 26th, 1865, æt. 65. 'If we believe that Jesus died and rose again, even so them also which sleep in Jesus will God bring with him.'*"

BRUNTINGTHORPE.

SILVER CUP WITH COVER PATEN. Weight of cup 4.9 oz. Height $5\frac{1}{2}$ in. Diam. of the bowl $2\frac{3}{8}$ in.; of the foot $2\frac{1}{4}$ in. Height of stem $2\frac{1}{2}$ in. Date 1634. (PLATE 28.)

Hall marks. 1. Italic R in a pointed shield. 2. Lion passant. 3. Leopard's head crowned; each of the two latter having an outside line following the outline. 4. E. S. a pellet above and below, within a dotted circle.

This little cup has a nearly straight-sided bowl with a flat base and the lip very slightly bell-shaped. The stem swells out, without a knob, into a plain round flat foot, underneath which the lion passant is repeated. The bowl is beaten out of one piece of metal, the stem and foot out of another.

SILVER COVER PATEN with a foot. Weight 1.6 oz. Diam. $3\frac{1}{2}$ in. Diam. of the foot $1\frac{3}{8}$ in. Height of foot $\frac{5}{8}$ in. Date 1634. (PLATE 28.)

Hall marks as on the cup.

This is a flat paten with a vertical edge $\frac{1}{4}$ in. deep, the top of this edge being turned outwards $\frac{1}{8}$ of an inch in width. The foot is a disk, attached to the paten by a stem swelling out to both ends. This is an early, as well as unusually small, example of a cup and cover paten in this shape, which is found more often after the Restoration than before.

SILVER PLATED PATEN with a foot. Diam. 6 in. Diam. of the foot $3\frac{1}{2}$ in. Height of foot $1\frac{1}{4}$ in.

This paten is sunk deeply in a six-lobed depression. Underneath is "*Presented to Bruntingthorpe Parish Church by R. Worthington, Esqr Churchwarden 1871.*" The donor of this paten formerly resided in this parish and occupied land in the adjoining parish of Peatling Parva.

PEWTER FLAGON. Height $10\frac{1}{2}$ in. Diam. of top 3 in.; of foot $5\frac{3}{8}$ in. No marks.

This is a small straight-sided flagon narrowing to the top; having a flat top to the lid.

FOSTON.

SILVER CUP WITH COVER PATEN. Weight of cup 6 oz. Height $6\frac{1}{4}$ in. Diam. of bowl 4 in.; of the foot $3\frac{1}{2}$ in. Height of stem $2\frac{3}{8}$ in. Date 1670. (PLATE 25.)

Hall marks. 1. Capital old English N in a plain pointed shield. 2. Lion passant. 3. Leopard's head crowned; each of the two latter having an outside line following its outline. 4. I. C. with a cinquefoil below within a heart-shaped shield.

The bowl of this cup is in shape an inverted truncated cone slightly concave; it has a flat base, round the edge of which is a cable moulding $\frac{1}{8}$ of an inch thick. The stem is conical, swelling out gradually to a plain flat foot; the stem and foot being formed out of one piece of metal. Beneath the latter the lion passant has been repeated.

SILVER COVER PATEN with a foot. Weight 2.5 oz. Diam. $4\frac{1}{2}$ in. Diam. of the foot $2\frac{1}{2}$ in. Height of foot $\frac{7}{8}$ in. Date 1670. (PLATE 25.)

Hall marks as on the cup.

This is a flat-shaped paten having a vertical edge, the top of which is turned back outwards. The foot is a disk attached to the paten by a straight round stem. The lion passant is repeated on the foot.

SILVER FLAGON. Weight 41.1 oz. Height $10\frac{1}{2}$ in. Diam. at the top 3 in.; at the foot $3\frac{3}{4}$ in. Date 1715. (PLATE 25.)



Fig. 43.

Hall marks. 1. Court-hand V in a pointed shield. 2. Britannia. 3. Lion's head erased. 4. C. L. with a pellet below, within a heart-shaped shield.

This is a jug-shaped flagon, having evidently been once a secular piece of plate. It has a wide neck swelling out into the middle part below, underneath which is a plain round foot. At the top is a covered spout, there being half way over it, attached to a hinge, a little flap, which is lifted up when the flagon is used. The lid has a flat top, out of which rises a flat stage, surmounted by a knob. In front is this coat of arms: *Argent on a canton Sable, a lion's jamb erect and erased Or; Boothby.* (FIG. 43.) On one side is: "*This flagon was the gift of Charles Skrymsher Boothby, Esq., and of Anne, his wife, to this parish, weighing 41 ounces 4 dwts., 1781.*"

A similar flagon was given to Ratby by the same donors, on which is engraved the seal of Lichfield city; the circular shield seems to have been designed specially for that badge rather than for the coat of Boothby. (Vide page 327.)

GILMORTON.

SILVER CUP. Weight 6.9 oz. Height $7\frac{3}{8}$ in. Diam. of bowl $3\frac{3}{4}$ in.; of foot $3\frac{1}{8}$ in. Height of stem $4\frac{1}{8}$ in. Date **1605.** (PLATE 28.)

Hall marks. 1. Lombardic H in plain shield. 2. Lion passant. 3. Leopard's head crowned, each with an outside line following the outline of the mark. 4. Stag's head between "W. A."; the letters are indistinct.

This cup has a V shaped bowl and a baluster stem, and is an early example of a cup of this shape. Round the bowl a band of vine leaves and grapes has been engraved in recent years, and round the top of the foot a band of lozenge ornament.

SILVER PATEN. Weight 4.2 oz. Diam. $6\frac{5}{8}$ in. Date **1860.**

London hall marks.

In the centre of this plain paten is the Agnus Dei, gilt, and round the edge "*O Lamb of God that taketh away the sins of the world, have mercy upon us.*"

SILVER FLAGON. Weight 18.7 oz. Height $11\frac{1}{2}$ in. Date **1861.**

London hall marks.

This flagon is jug-shaped, and it has inscribed round its middle "*Glory be to God on high.*" Underneath is "*Remodelled at the cost of the Rector's wife 1861.*"

PEWTER DISH. Diam. $9\frac{3}{8}$ in. Date **1675.**

Marks. 1. Rose crowned, with "**Tho. King**" above. 2. "Made in London." 3. Anchor crowned between the date "1675."

This and the Lutterworth dishes were made by the same maker.

In addition to the silver cup there belonged to this church in 1832 a silver flagon and two pewter plates.

At the cost of Mrs. **Lakin**, the wife of the rector, that flagon was exchanged in 1861 for the paten and flagon now in use. Mrs. **Lakin** was, **Barbara Louisa**, daughter of Mr. **William Smallwood**, of Sheldon, co. Warwick, by his wife **Barbara Holland**, and was born on 25th May, 1814. She married at Aston, co. Warwick, in 1844, the Rev. **John Marsh Lakin**, son of Mr. **John Lakin**, of Twycross, co. Leicester, by **Ann**, daughter of Mr. **Christopher Marsh**, of Bath, who was born on 6th August, 1816. Mr. **Lakin** entered Worcester College, Oxford, taking his B.A. degree from thence in 1839, and M.A. in 1843. He was ordained deacon by the Bishop of Hereford in 1840, and priest in 1841. He was presented to the perpetual curacy of Berrow, co. Worcester, in 1849, which he held till 1851, when he was appointed to the rectory of Gilmorton. Here as a parish priest and kindly neighbour he was much esteemed by his parishioners and many friends around. The body of the church through the efforts and liberality of its rector was rebuilt in 1860. Mrs. **Lakin** died on 3rd March, 1878, and was buried in the churchyard of this parish. Her husband in 1881 resigned the living of Gilmorton and the rural deanery of Guthlaxton III., taking in the

year following the smaller cure of Brooksby, in this county, which he held till his death on 24th July, 1886.

He was buried beside his wife, who had borne him four daughters, the second of whom is the wife of the Rev. **J. H. M. de Mowbray**, rector of Knossington. Mr. **Lakin's** former parishioners and friends have placed in the north aisle of Gilmorton church a stained glass window to his memory, the subject of which is the "Nunc Dimittis."

NORTH KILWORTH.

SILVER CUP. Weight 3.4 oz. Height $4\frac{3}{4}$ in. Diam. of bowl $2\frac{5}{8}$ in.; of foot $2\frac{3}{8}$ in. Height of stem $1\frac{3}{8}$ in. Date **1569**. (PLATE 29.)

Hall marks. 1. Small black-letter M in plain shield. 2. Lion passant. 3. Leopard's head crowned; each of these two marks having a line following its outline. 4. Capital Roman A in a shaped shield.

The bowl of this little cup is an inverted truncated cone in shape, slightly bell-shaped. Round its lip is a band of Elizabethan foliage, divided into three parts by hour-glass curves; and lower down a band of stroke ornament. The stem, which is without a knob, is quite plain, swelling out towards each end. The foot is high, and quite plain in shape, being a raised dome ending in a flat edge.

SILVER PATEN with foot. Weight 9.4 oz. Diam. $7\frac{1}{8}$ in. Diam. of foot $2\frac{5}{8}$ in. Height of foot 2 in. Date **1723**.

Hall marks. 1. Capital Roman H in a plain shield. 2. Leopard's head crowned, in plain rounded shield. 3. Lion passant in a narrow oblong. 4. Capital Roman M, with a mullet above and below, within an oval.

This paten is quite plain in shape. Round the edge is: "*North Kilworth, 1724. The gift of Hannah Willes, widow of Wm. Willes, Esq., daughter of Doctr Cotton, who was formerly a loyall and suffering rector of ye church.*"

SILVER FLAGON. Weight 35.7 oz. Height $10\frac{7}{8}$ in. Diam. at top $3\frac{1}{2}$ in.; at foot $6\frac{1}{8}$ in. Date **1724**.

Hall marks. 1. Capital Roman I in rounded shield. 2. Lion passant in oblong. 3. Leopard's head crowned, in rounded shield. 4. T. T. with a cinquefoil above; the mark of *Thomas Tearle*.

This flagon is straight-sided in shape, narrowing towards the top. The lid has a round top with a knob on it. In front is the same inscription as that on the paten.

PEWTER DISH. Diam. $9\frac{1}{2}$ in.

Marks. 1. X crowned. 2. A crown. 3. London. 4. In four small shields: (a) S. D. (b) Lion's head erased. (c) Three lions' heads erased. (d) Indistinct.

This was formerly used as an alms dish.

Hannah Willes was the daughter of the Rev. **Samuel Cotton**, D.D., by **Margaret**, his wife, and was baptized at North Kilworth, on the 21st Dec., 1642.* Mr. **Cotton**, who was probably the third son of **William** and

* Parish Register.

Ann Cotton, of Laughton, mentioned in the visitation of 1619 as aged 16, was presented to the rectory of Cotesbach in 1634, and to North Kilworth, in 1641, from both of which he was ejected during the Commonwealth. His wife applied in 1647 to the committee of sequestration, for the one-fifth part of the income of this living, which was the portion they were supposed to allow the family of an ejected minister, but she seems to have applied in vain.† No doubt the daughter looked back upon the days of her childhood with a lively recollection of the persecution endured by her father for his loyalty. **Samuel Cotton** does not appear to have returned to either of his livings after the restoration, but was made a prebendary of Lincoln on the 4th Oct., 1660.† His daughter **Hannah**, was married at Exton, co. Rutland, on the 3rd April, 1684,‡ to **William Willes** a landowner of that place, the son of **Henry** and **Catherine**, baptized there on 1st Dec., 1658.‡ **William Willes** died without issue, and was buried at Exton on 7th Dec., 1723.‡ His widow survived him not quite two years; she was buried at Exton on the 3rd Oct., 1725.‡

In addition to the gift to this church Mrs. **Willes** gave in 1724 a silver flagon to Langham, co. Rutland, where her father had once been curate. She and her husband gave also just before his death a silver flagon to Empingham church in that county.§

William Willes, "of Exton, gent.," by will dated 17th May, 1720, and proved P.C.C. 15th Jan., 1723-4, left to his wife land at Exton bought of **John Carrier**, land at Knossington bought of Mr. **Wilcocks**, land at Welham bought of Mr. **Sprigg** and others, and all other real and personal property. To Sir **T. Mackworth**, Bart., 50 guineas; to **Joshua Blackwell**, Esq., 50 guineas; and to **Tho. Rose**, of the two Eagles, Ludgate Street, 10 guineas, these legacies to be paid after wife's death, whom he appointed sole executrix.

Hannah Willes by her will dated 17th June, 1725, and, with a codicil dated 14th Sep., proved P.C.C. 4th Dec., 1725; left to trustees all houses and land and great and inappropriate tithes in Welham, with directions that that property should be sold and the proceeds devoted as follows; to augment the stipend of the minister in conjunction with **Queen Anne's Bounty** £200 to each of these five livings, viz., Exton, Empingham, St. Mary's, Stamford, one chosen by the Rev. **Henry Cantwell**, clerk, and another chosen by all the trustees. £100 to Charity School in Stamford called the Spinning School, to be laid out in land. £20 to each of these parishes for their poor, North Kilworth, North Wytham, and Exton; £10 each to Castle Bytham and to Langham, co. Rutland; these sums to be paid to the respective incumbents and to be laid out by them in land, the interest being devoted yearly by the minister for the time being to the poor as he shall think fit, "particularly to the aged, lame, and blind." £210 to **Hannah Weston**, daughter of **Nat. Weston**, of Exton, Clerk. £50 to **William**, son of **Henry Cantwell** and **Constance** his late wife. £100 to "my nephew," **Henry Ravenell**, gent.; to Mr. **Henry Heyrick**, of Exton, £20. Many other legacies to friends and servants; amongst others to brother **John Cotton** and his daughter **Sarah**, wife of **George Cox**. All lands in Knossington to **Henry** eldest son of **H. Cantwell**, clerk, charged with the yearly payment of £20 to her trustees for the benefit of four widows, with a child or children, of clergymen of

* *Publica. Harl. Soc.* Vol. ii., p. 191. + *Nichols*, Vol. iv., p. 200. In Walker's *Sufferings of the Clergy*, no information is given of him beyond his ejection from North Kilworth. † Parish Register. § *Church Plate in Rutland*, by R. C. Hope, F.S.A., pp. 7 and 14.

the Church of England. Tenement and land in Exton called Carrier's close to **Sarah Cox** for life, and then to **William**, son of **H. Cantwell**, clerk, and to him also a tenement and malting office in Exton. House in which she lived in Exton, with land in open fields to husband's niece **Christiana Willes** for life, and then to **Henry**, son of **H. Cantwell**. Her coach and horses and household goods to **Christiana Willes**, **Mary Cantwell**, and **Hannah** wife of **Nathaniel Weston**, equally; **Hannah Weston** sole executrix.

SOUTH KILWORTH.

SILVER CUP. Weight 10.7 oz. Height $8\frac{1}{4}$ in. Diam. of bowl and of foot $4\frac{1}{4}$ in. Date 1845.

London hall marks.

This is a plain-shaped cup, having in front of its bowl the sacred monogram within a circle of glory. On the edge of the foot is "*South Kilworth.*"

SILVER PATEN with a foot. Weight 14.8 oz. Diam. $8\frac{3}{8}$ in. Diam. of foot 4 in. Height of foot 3 in. Date 1845.

There is the sacred monogram in the centre of this plain paten.

SILVER DISH. Weight 12.9 oz. Diam. 9 in. Date 1845.

There is the sacred monogram in the centre of this dish.

SILVER FLAGON. Weight 28.2 oz. Height $14\frac{1}{4}$ in. Diam. of top $3\frac{3}{4}$ in.; of foot $6\frac{3}{4}$ in. Date 1844.

This is a straight-sided flagon in shape.

In the terrier of 1708* the communion plate belonging to this parish is thus described; "a silver chalice with a cover weighing $9\frac{3}{4}$ oz.; a large pewter flagon; a pewter plate."

The pewter flagon is not included in Archdeacon **Bonney's** inventory of 1832.

The silver cup and cover were parted with some years ago during the incumbency of the late Ven. **Assheton Pownall**, F.S.A., Archdeacon of Leicester; kindly memories for whom live in the hearts of all who knew him.

The present silver service was the gift of the Rev. **William Pearson**, LL.D., F.R.S., who was a member of an old statesman family. He was the second son of **William Pearson**, by his wife **Hannah Ponsonby**, and was born at Whitbeck, Cumberland, on 23rd April, and baptized there on 31st May, 1767.† He was educated at Hawkeshead Grammar School. In 1811 Dr. **Pearson** became proprietor of the preparatory school at Temple Grove at East Sheen, remaining there till 1821, when he moved finally to South Kilworth; he had been presented to this living by the King,

* Quoted in "Some records of South Kilworth;" *Associated Architectural Societies Reports*, Vol. xv., p. 242.

† Parish Register. On the South side of Whitbeck church, is a mural tablet commemorating four generations of this family; the first being Dr. **Pearson's** grand-parents, John and Frances, who died on 7th Feb., and 23rd Nov., 1772, æt. 81 and 70.

and instituted on 15th March, 1817.* As an astronomer and one of the founders of the Royal Astronomical Society, Dr. **Pearson** has caused his name to be remembered. He contributed many articles to Rees' *Cyclopædia*, and in 1824 brought out the first large 4to. vol. of his great work "A Treatise on Practical Astronomy," publishing the second in 1829. In early life he had a strong liking for mechanism and made various astronomical instruments with his own hands.† He died on 6th Sep., 1847, and was buried in this church where, on the North wall of the nave, is a marble tablet to his memory.

The Rev. **W. Pearson** was twice married; his first wife **Frances** died on 10th Oct., 1831, aged 60, leaving one daughter **Frances**, who married first **William Palmer Moffat**, Esq., and then **Thomas Pochin**, Esq., and died without issue in 1869; her father's second wife, **Eliza Sarah**, outlived Dr. **Pearson** many years, and died without issue on 18th Dec., 1878, aged 81, and was buried at Tunbridge Wells.

In his will, made 9th Feb., 1844, and proved with two codicils dated 25th Sep., 1845, and 30th Aug., 1847; on 2nd Dec., 1847, P.C.C., Dr. **Pearson** left his house and gardens in the manor of Troutbeck, Windermere, bought by him and called "the Briery," to his wife **Eliza Sarah** for life, and in addition to her marriage settlement of £500 a year, another £500 a year for life charged on his lands in the counties of Oxford, Northants, Leicester and Warwick; subject to that charge his land in those counties he left to his nephew **William Pearson**, of Husbands Bosworth, and after his death to his eldest son; money in the funds to trustees for use of his daughter **Frances**, in addition to £5000 already settled on her; legacies to nephews and nieces: executors, **Eliza Sarah** his wife, **William** only son of late brother **John Pearson**, **William Edward Maxwell**, and nephew **Joseph Patrickson**, of Barnsbury Park, Islington.

In addition to this gift of church plate, the Rev. **W. Pearson** was a benefactor to this parish by being the first to provide it with school buildings, and by endowing the school with £700; he also rebuilt the North aisle to the church. His successor, Archdeacon **Pownall**, enlarged the schools and, with considerable help from Dr. **Pearson's** family and others, rebuilt nearly the whole church.

The present owner of Dr. **Pearson's** property, is his great nephew, Col. **William Pearson**, of The Cottage, North Kilworth.

KIMCOTE.

SILVER CUP WITH COVER PATEN. Weight of cup 5.8 oz. Height $6\frac{1}{8}$ in. Diam. of bowl $3\frac{1}{2}$ in.; of foot $2\frac{7}{8}$ in. Height of stem 2 in. Date 1567. (PLATE 27.)

Hall marks. 1. Small black-letter K, with annulet beneath, in a plain shield. 2. Lion passant. 3. Leopard's head crowned; each of these two having an outside line following its outline. 4. Oblong eight-pointed mark in outline of same shape.

This cup is of the same character as those at Goadby Marwood and Foxton, made by the same maker in the same year.‡ Its bowl is in shape an inverted truncated cone, very slightly convex, and with a bell-shaped lip. The stem, which has no knob, is short and

* Bishop of Lincoln's Register. † *Vide* Biographical notice in *Report of Royal Astronomical Society*, Vol. viii., p. 69.

‡ Plate xiii.

straight, swelling out at each end into vertical edges, round which run several lines. Round the edge of the foot is the egg and tongue ornament. When I first saw this cup it had round the bowl the remains of a small moulding $\frac{1}{8}$ in. thick and $\frac{1}{4}$ in. wide; fastened on to the surface of the bowl, only about 2 in. of which was left, the rest having been broken off; on its edge there was a very small cable moulding. This fragment has since been taken off and a new moulding, with lines running round it, put on.

SILVER COVER PATEN with foot. Weight 2.3 oz. Diam. $3\frac{3}{4}$ in. Diam. of foot $1\frac{3}{8}$ in. Height of foot $\frac{1}{2}$ in. Date 1567. (PLATE 27.)

Hall marks as on the cup.

There is the usual rim round the inside edge of the paten. The foot is a disk attached to the cover by a stem, swelling out at both ends. The paten fits on to the cup both ways.

SILVER PLATED PATEN. Diam. $7\frac{1}{8}$ in.

SILVER PLATED DISH. Diam. 9 in.

SILVER PLATED FLAGON. Height $11\frac{3}{4}$ in.

PEWTER BASIN. Diam. $9\frac{5}{8}$ in. Height $4\frac{1}{4}$ in.

No marks.

TWO PEWTER DISHES. Diam. $9\frac{1}{4}$ in.

Marks. 1. X crowned. 2. Horse's jamb rising out of crown. 3. "London." 4. In four small shields: (a) S. D. (b) Lion's head erased. (c) Lion's tail erased. (d) Indistinct coat of arms.

Nichols (Appendix p. 142) gives some extracts from the churchwardens' accounts of this parish, which were then in the possession of Mr. J. Lucas, surgeon of Kimcote. Amongst these extracts is this one: "1608. Paid for the pewter flagon, 8s. 2d." This flagon has long ago disappeared; it is not mentioned by Archdeacon Bonney.

MOWSLEY.

SILVER CUP. Weight 9.7 oz. Height $7\frac{1}{2}$ in. Diam. of the bowl and of the foot $3\frac{7}{8}$ in. Height of stem $3\frac{1}{4}$ in. Date 1663.

There is one mark only on this cup, viz., the maker's, P. B. a crescent above and below, a pellet in each corner, the whole within an oblong. Mr. Cripps mentions different pieces of plate belonging to the Innholders' Company which were made by this maker, whomsoever he may have been, in the years 1658 and 1661.*

The bowl of this cup is straight-sided with a bell-shaped lip. The stem, which is quite plain, has a large plain round knob. Underneath the foot is "*Mowsley cup, 1663.*"

SILVER PATEN. Weight 4.1 oz. Diam. 6 in.

In the centre of this plain modern paten is engraved a figure of the infant Saviour upon a cross, surrounded by this inscription, "*If thou hast little do thy diligence gladly to give of that little.*" Underneath is, "*Laus Deo. Given to the church of St. Nicholas, Mowsley, by the guild of the Holy Child Jesus 1879.*"

* *Old English Plate*, p. 324.

PEWTER FLAGON. Height $13\frac{1}{2}$ in. Diam. at the top $3\frac{3}{4}$ in.; at the foot $7\frac{1}{4}$ in.

Marks. 1. K. H. 2. Lion's head erased. 3. On a fesse, three escalops. 4. Leopard's head.

This flagon is straight-sided in shape, narrowing towards the top. The knob to the lid has been broken off.

TWO PEWTER PLATES. Diam. of each $8\frac{3}{8}$ in.

Marks on each. 1. An eagle displayed between the letters W. G. 2. A rose crowned. 3. London.

Both are of the usual shape.

The guild of the Holy Child Jesus has been formed in this parish in order that the members thereof may assist and support one another in the cultivation of personal holiness, and unite in extending the teaching and work of the church. In addition to the silver paten this guild has made various other gifts to Mowsley church.

SHEARSBY.

SILVER CUP. Weight 11.3 oz. Diam. of the bowl $4\frac{1}{4}$ in.; of the foot 5 in. Height of stem 5 in. Date 1879.

London hall marks.

The bowl of this cup is of the shape of an inverted truncated cone. The stem, knob, and foot are round. Underneath the paten is, "*Shearsby*, 1879."

SILVER PATEN. Weight 4.3 oz. Diam. 6 in. Date 1879.

This paten has a flat edge, the middle part being sunk. In the centre is the sacred monogram upon a cross, gilt. Underneath is, "*Shearsby*, 1879."

PEWTER FLAGON. Height $13\frac{1}{4}$ in. Diam. at the top $4\frac{1}{2}$ in.; at the foot $5\frac{1}{2}$ in.

No marks.

This is a tall, narrow, straight-sided flagon, diminishing towards the top. It has a round top to its lid which is surmounted by a knob. The purchase is a very large one.

PEWTER PLATE. Diam. $10\frac{1}{4}$ in.

Marks. 1. On the edge in four small shapes (*a*) G. S. (*b*) A buckle. (*c*) and (*d*) A mark shaped like a T rising out of a globe. 2. Underneath, G. S.; above, some illegible device within a dotted circle.

This plate has a flat edge $1\frac{1}{8}$ in. wide, the middle part being sunk flat $\frac{3}{8}$ of an inch in depth. Upon the edge of the plate is engraved "*Shearsbe*."

PEWTER PLATE. Diam. $8\frac{3}{8}$ in.

Marks. On the edge. 1. S, for Shearsby. 2. In a small lozenge I. A. 3. In a small lozenge, a T rising out of a C placed on its side, this latter mark being stamped three times.

This plate has a flat edge 1 in. wide, the middle part being sunk flat $\frac{3}{8}$ of an inch deep. This was in all probability formerly used as a paten, until the silver plate, mentioned below, was given by Mr. **George Turvile**.

In an undated terrier signed by **Thomas Sawbridge**,* and probably made in 1709, the church plate here is thus described; "A large pewter flagon and two pewter plates weighing nearly 8 lbs.; and a silver cup weighing 6 oz.; for the font a basin weighing 2 lbs." There was also formerly here a silver plate with this inscription on it; "*Ex dono Geo. Turvile anno 1724.*"

The ancient silver cup, judging from a description of it given me by the present rector, was made about 200 years ago. When held up in a strong light, traces of an inscription purposely obliterated could be seen upon it. This cup and the silver plate given by **G. Turvile**, whom I have failed to identify, were both sold when the modern pieces were bought.

The modern silver cup and paten were bought with money collected amongst the parishioners of Shearsby and other friends in 1879.

MISTERTON.

SILVER CUP. Weight 8.6 oz. Height $6\frac{3}{8}$ in. Diam. of the bowl $3\frac{1}{2}$ in.; of foot $3\frac{3}{8}$ in. Height of stem $3\frac{1}{4}$ in. Date **1642.** (PLATE 29.)

Hall marks. 1. Court-hand E in a plain shield. 2. Lion passant. 3. Leopard's head crowned: each of these two last having an outside line following its outline. 4. W. O., with a heart and two pellets below, within a plain shield.

This cup has a bowl shaped into an inverted truncated cone, a baluster stem, and a plain flat foot. On the bowl is: "*Misterton, 1645;*" the letters being formed by means of little indentations made by pricking the silver with a sharp pointed instrument.

(a)

SILVER PATEN. Weight 8 oz. Diam. $8\frac{5}{8}$ in. Date **1638.** (PLATE 29.)

Hall Marks. 1. Small black-letter A in a plain shield. 2. Lion passant. 3. Leopard's head crowned; each of these two having an outside line following its outline. 4. P. G., with a rose below, within a trefoil.

This paten is quite plain in shape, being sunk in the middle. On the edge is: "*Donu Margaretta Pulteny;*" and three laurel wreaths enclosing, 1. *Argent, a fesse dancetté Gules, in chief three leopards' faces, Sable, Pulteny;* impaling: *Argent, two bars Gules, in chief three cinquefoils Sable, Denton;* 2. Crest: *a leopard's face Sable, Pulteny;* 3. Crest: *a lion passant, Or, Denton.*

(b)

SILVER FLAGON. Weight 22.1 oz. Height $10\frac{5}{8}$ in. Date **1868.**

London hall marks.

This flagon is straight-sided, and quite plain in shape. On the foot is: "*Presented by Emma Teush Hecker, to the church of St. Leonard's, Misterton, 1869.*"

(a)

The donor of the paten was **Margaret**, the daughter of Sir **Thomas Denton**, Knt., of Hillesdon, Bucks, by **Susanna**, his wife, and was baptized

* Incumbent from 1700-1713.

at Hillesdon, on 15th Nov., 1612.* This lady married three husbands. Her first was **John Pulteney**, the last of his name to own the ancient inheritance of his family in this parish. He was the only son of Sir **John Pulteney**, Knt.; was baptized at Westminster Abbey on 15th May, 1610, and died without issue at Leicester, on 15th May, 1637, aged 27.

In his will made 9th May, 1637, and proved at Leicester with a codicil dated 10th May, on 2nd Jan., 1637-8, **John Pulteney**, "of Misterton, Esq.," left; to the churchwardens of Misterton £5 for a pulpit cloth; to poor of Shenley, Herts, £10; to sisters, the **Lady Crew**, Mrs. **Brownlow**, and Mrs. **Mary Pulteney** £20 each; to **Anne** and **Francis**, children of **Lady Crew**, £100 each; to niece **Margaret Burney**, "now living with me" £100; to friend **Joseph Bryan**, of Gray's Inn, Esq., £10; to Exeter Coll., Oxford, "of which college I once was," £100; all rest of goods, plate etc., together with term of years yet unexpired which I have in messuages, fields, woods etc., lately by indenture of demise, bearing date 16th March, twelfth year of King **Charles**, assigned by **John March**, of Shenley, yeoman, unto **Edward Butterfield**, of Leicester, gent., "my servant," "in his own name but only in trust," I give to **Margaret**, my wife and sole executrix; to **Edward Butterfield**, my servant, manor of **Couts Devil**, and lands, tenements etc., in **Kimcote**, subject to very many annuities and legacies; amongst the former; £10 a year to mayor, bailiffe, and burgesses of Leicester for the poor of that borough, and £10 a year to the minister and churchwardens of Misterton for the poor of the same, amongst the legacies; £10 to **Dr. Hodges**, D.D.; £50 to **Mr. Crowther**, clerk; £50 to **Mr. Bent**, clerk; £5 to **Mr. Angel**, clerk; £5 to **Mr. Watkin**, clerk; £20 to godson **John**, son of **William Garland**; £20 to godson **John**, son of **Peter Whitfeild**, deceased; £10 each to servants; and out of same manor and lands, a debt of £1040 owing to **John March**. In codicil: to wife **Margaret**, house "I now live in" in the street called **Swynes street**, in **St. Martin's parish**, **Leicester**, also "one little plot" in **St. Mary's**, in **High street**; to wife, "my manor of **Belgrave** with all quit rents etc."

Margaret Pulteney married secondly **Col. William Eure**, the second son of **William**, Lord **Eure**: the Colonel lost his life in the service of the King in 1645, leaving two daughters who became co-heiresses of **William**, Lord **Eure**, viz: **Margaret**, and **Maria Pulteney**; the former married **Thomas Danby**, the latter, **William Palmes**.† Their mother's third husband was **Phillip Sherard**, Esq., of **Whissendine**, M.P. for **Rutland** from 1660 to 1685, the second son of **William Sherard**, of **Stapleford**, 1st Lord **Sherard**. She bore her third husband with other children, a son, **Bennet**, whose son, **Phillip**, succeeded his cousin **Bennet**, 1st Earl of **Harborough**,‡ and from him the late **Robert Sherard**, 6th and last Earl of **Harborough**, was directly descended.

Upon the death of the late Earl of **Harborough** in 1859 the earldom became extinct: his other title of **Baron Sherard** passing to his kinsman, **Phillip-Castell Sherard**, who is a descendant of **George**, third son of **William**, first Lord **Sherard**.

It is not unlikely but what **Margaret Pulteney** gave this silver paten in 1638 to **Misterton** in memory of her first husband. In any case she erected a handsome monument to him in **Misterton church**. This is an altar-tomb with a long inscription on the East end.

* Parish Register.

† See Wright's *Rutland*, p. 134.

‡ Page 140.

and on the other three sides many coats of arms showing the matches made by the **Pulteneys**.* This monument was formerly at the West end of the South aisle; it was put against the North wall of the chancel when the church was recently restored; the end upon which the epitaph is now faces East.

The donor of this paten was buried at Whissendine, the abode of her third and last husband, on 14th Dec., 1688. **Phillip Sherard** died at the age of 71, and was buried at Whissendine on 4th March, 1694-5-† No monument was placed to their memory. **Margaret Sherard** had a life interest in her first husband's estates in this parish; after her death they mostly passed to his nephew, **John Crew**, ancestor to the present Lord **Crewe**.

(b)

The donor of the silver flagon was **Emma**, daughter of **Jacob Henry Franks**, Esq., of Misterton Hall, by his wife **Elizabeth Wilkes**, and was born on 24th Feb., 1814. This lady married on 27th June, 1841, at Trinity Church, Sloane Street, London, the Rev. **Henry Teush Hecker**, M.A., who was born on 13th April, 1807. Mr. **Hecker**, having first held successively the curacies of New Radnor, Sevenoaks, and Wheathampstead, was appointed to the vicarage of St. Ann's, Aigburth, which he held till 1868, when he was presented by his relative to the rectory of Misterton, of which parish he was incumbent till his death on 19th Feb., 1880. Mrs. **Hecker** died on 23rd Dec., 1875. Both are buried in the churchyard here, together with a son and daughter. A large cross of red granite marks Mr. **Hecker's** grave. In the church is a painted window, and a reredos representing the Last Supper, to record the memory of Mrs. **Hecker**. Their only surviving children are two daughters, the youngest of whom is the wife of the Rev. **C. Rodwell**, rector of Kimcote.

PEATLING PARVA.

SILVER CUP WITH COVER PATEN. Weight of cup 6.7 oz. Height 6 $\frac{3}{8}$ in. Diam. of bowl 3 $\frac{1}{4}$ in.; of foot 2 $\frac{3}{8}$ in. Height of stem 2 $\frac{3}{4}$ in. Date 1569 (PLATE 27.)

Hall marks. 1. Small black letter M in plain shield. 2. Lion passant. 3. Leopard's head crowned; each of these last two marks having an outside line following its outline. 4. A fringed heart or perhaps sun in splendour.

The bowl of this cup is in shape an inverted truncated cone, having round it a band of foliage divided into three distinct parts, each connected by light sprays. The stem is of the usual evenly-balanced shape; round the base of the bowl, as well as round the edge of the foot, is the egg and tongue ornament.

* *Nichols*, Vol iv., pp. 314 and 319.

† Parish Register.

SILVER COVER PATEN. Weight 1.9 oz. Diam. $3\frac{1}{2}$ in. Diam. of foot $1\frac{3}{8}$ in. Height of foot $\frac{7}{8}$ in. Date 1569. (PLATE 27.)

Hall marks as on the cup.

This cover is of the usual shape, having round its edge on the outside, a band of stroke ornament; there is the same ornament, much worn away, on the foot.

SILVER PATEN with foot. Weight 4.2 oz. Diam. 5 in. Diam. of foot 2 in. Height of foot $\frac{7}{8}$ in. Date 1721.

Hall marks. 1. Capital Roman F in a plain shield. 2. Britannia. 3. Lion's head erased. 4. L. O. in a monogram, within an oval: the mark of *Matthew E. Lofthouse*.

This paten is sunk in the middle, having a raised edge $\frac{3}{8}$ of an inch wide. In the centre is this coat of arms; *Argent, three falcons close Gules; Falkener; impaling; Paly of six Argent and Sable, on a bend Vert three trefoils slipt Or; Falconer.* (FIG. 44.)



Fig. 44.

PEWTER FLAGON. Height $10\frac{5}{8}$ in. Diam. of top $4\frac{1}{4}$ in.; of foot $5\frac{1}{2}$ in.

One mark only; W. S. within a heart, on the bottom of the flagon inside.

This flagon is in shape straight-sided, narrowing towards the top. It has a flat top to its lid, which is surmounted with a knob.

PEWTER DISH. Diam. $6\frac{1}{2}$ in.

Marks. "P. P." on the edge for "Peatling Parva." Underneath. 1. A rose crowned with "London" below. 2. A rose with a pigeon on it; "John" above; an illegible name below. "London" is underneath both marks.

The coat of arms shows the silver paten to have been the gift of a **Falkener**, but it cannot be said which member of that family made the gift; nor has it even been possible to connect in any way the name of **Falkener** with this parish. The head of the family in 1721, was **Lion Falkener**, of Uppingham, whose will made 11th Sept., 1722, and proved P.C.C. 22nd March, 1722-3, contains no such bequest as this: his wife **Mary**, was his sole executrix.

It is just possible that her maiden name was **Falkener**, and that on this paten her arms are impaled with those of her husband. An excellent pedigree has been published by the head of this family, Mr. **Edward Falkener**, of Glanymor, St. Clear's;* in it he has shown that the right arms of his family are: *Argent, three falcons close Gules*, and that the other coat here impaled was that of **Thomas Fauconer**, Lord Mayor of London, 1414-15. But this second coat, *Paly of six Argent and Sable, on a bend Vert three trefoils slipt Or*, has until recent years been frequently in ignorance borne by the **Falkeners**, of Uppingham, they thinking themselves to have been descendants of the Lord Mayor. So that the two coats on the paten may be the arms of two members of the same family, the wife being a cousin perhaps, more or less distant, of her husband's.

* In *The Genealogist*, New Series, Vol. i., p. 129. Reprinted in *Leicestershire Pedigrees*, by W. G. D. Fletcher

WILLOUGHBY WATERLESS.

SILVER PLATED CUP. Height $7\frac{3}{8}$ in.

This is a two-handled cup, with an egg-shaped fluted bowl, and thin stem with a fluted foot.

TWO SILVER PLATED DISHES. Diam. of each $11\frac{1}{4}$ in.

THREE BRITANNIA METAL BASINS. Diam. of each $10\frac{3}{8}$ in.

PEWTER FLAGON. Height $10\frac{3}{4}$ in. Diam. at top 4 in.; at foot 6 in.

No marks.

This is a straight-sided flagon narrowing a little towards the top, having an R-shaped handle.

In 1832 there was here, "a good pewter flagon; a plain silver cup inscribed '*Tho. Gamble, churchwarden, 1705*'; two pewter plates." The silver cup was sold in 1875, and the plated pieces bought.

PEATLING MAGNA.

SILVER CUP. Weight 7.8 oz. Height $6\frac{1}{2}$ in. Diam. of bowl $4\frac{1}{2}$ in.; of foot $3\frac{1}{2}$ in. Height of stem $4\frac{1}{2}$ in. Date 1603. (PLATE 28.)

Hall marks. 1. Lombardic F in a plain pointed shield.* 2. Long-shaped lion passant. 3. Leopard's head crowned; each of the two latter having an outside line following its outline. 4. D, with a short horizontal line across the middle of the upright stroke, within a stamp of the same shape as the letter.*

This cup is a tazza, the only other belonging to a Leicestershire church being the later one at Shenton.† This has a shallow globular bowl, a tall narrow baluster stem and a flat sloping foot. The bowl is quite plain without any ornament at all.

SILVER CUP WITH COVER PATEN. Weight of cup 11 oz. Height $7\frac{1}{4}$ in. Diam. of bowl, of foot and height of stem $3\frac{3}{8}$ in. Date 1634. (PLATE 28.)

Hall marks. 1. Small italic R in a plain pointed shield. 2. Lion passant. 3. Leopard's head crowned; each of these two latter having an outside line following its outline. 4. H. C. in monogram, a pellet below, within a shaped shield.

This cup has a bowl shaped into an inverted truncated cone, having a flat base, and a slightly bell-shaped lip. Across the stem is a plain disk, from which the stem, which is plain and round, gradually swells into the foot, underneath which the lion passant is repeated. In front of the bowl is this coat of arms, within a laurel wreath: *Sable, a chevron Ermine between three hawks, Argent; Jervis.*

SILVER COVER PATEN with a foot. Weight 6.3 oz. including lead in the foot. Diam. $4\frac{1}{2}$ in. Diam of foot 2 in. Height of foot $1\frac{1}{8}$ in. Date 1634. (PLATE 28.)

* The tongue of the F projects almost as far as the top stroke. The D is more the shape of an old English than of a Roman capital. † *Vide infra*; Sparkenhoe II.

No hall marks.

This paten which is quite plain in shape, has round its inside a raised rim, the inside of the paten being sunk. The stem of the foot is concave, swelling out both towards the top of the paten and also towards the foot, which latter is a plain disk.

PEWTER FLAGON. Height $12\frac{1}{2}$ in. Diam. of top $4\frac{1}{2}$ in.; of foot $6\frac{1}{4}$ in.

Marks. Under foot. 1. X crowned. 2. An escalop shell with "Henry" above, "Joseph" below. 3. On the drum at the top; a lion passant in a small oblong, repeated four times.

This is a straight-sided flagon narrowing towards the top. It has an R-shaped handle, and a raised lid with a knob on the top.

PEWTER PLATE. Diam. $8\frac{1}{2}$ in.

Marks. 1. An eagle displayed with "Thomas" above, "Hodgkin" below. 2. "London." 3. "P. Magnay," for "Peatling Magna."

This is a plain plate.

The tazza, originally a secular piece of plate, was probably the gift of one of the **Jervises**, that family being lords of the manor and principal landowners here, while the **Bradgates** were the chief people at Peatling Parva.

The coat of arms on the cup, shows that that piece with its cover, was certainly the gift of one of the former family, the head of which, in 1634, was **William Jervis**, the eldest son of **George Jervis**, of this place, by **Elizabeth**, daughter and heir of **Michael Henshaw**, of Maldon, Essex. He sprang from a Thorpe Langton family, the head of which, soon after the dissolution of monasteries, acquired the manor of Peatling Magna.* **William Jervis** married the daughter of — **Adderley**, of Weddington, co. Warwick, by whom he had two sons and six daughters; from the eldest son, **Samuel**, was descended Dr. **Johnson's "Tetty."**

In his will made 10th Jan., 1653, and proved, with a codicil dated 14th March, 1658, P.C.C. on 8th Oct., 1661, **William Jervis** left certain lands in trust to **Ambrose Saunders**, of Foxton, **John Chamberlaine**, of Newton Harcourt, and **Adam Kirke**, of Little Peatling, they to raise out of such lands £500 for his daughter, **Elizabeth**, wife of **William Bale**, and the same sum for each of his other daughters, **Katherine**, **Susan**, **Jane**, **Mary**, and **Abigail**, to be paid them on their marriage or when 21; to **William**, "younger son" £1000 when 24. Executor and residuary legatee, eldest son, **Samuel**. In his codicil the legacy of £1000 to **William** is revoked, and in lieu thereof he orders his trustees to allow that son £40 a year for life; they also to allow testator's brother, **Henry Jervis**, £30 a year for life.

* For pedigrees see *Nichols*, Vol. ii., p. 671 and iv., p. 334.



SPARKENHOE FIRST DEANERY.

APPLEBY.
 COALVILLE.
 CONGERSTONE.
 FENNY DRAYTON.
 HEATHER.
 HUGGLESCOTE.
 IBSTOCK.

NAILSTONE.
 NEWBOLD VERDON.
 NORMANTON-LE-
 HEATH.
 NORTON-BY-
 TWYXCROSS.
 ORTON-ON-THE-
 HILL.

SHACKERSTONE.
 SHEEPY.
 RATCLIFFE CULEY.
 SIBSTONE.
 TWYXCROSS.
 GOPSAL.
 WITHERLEY.

APPLEBY.

SILVER CUP. Weight 7.1 oz. Height $6\frac{5}{8}$ in. Diam. of bowl $3\frac{1}{2}$ in.; of foot 3 in. Height of stem 3 in. Date 1725.

Hall marks. 1. Capital Roman K in a plain shield. 2. Leopard's head crowned in a plain shield. 3. Lion passant in a plain oblong. 4. S. A., two pellets below, in a shaped square; the second letter is indistinct.

This cup has a bowl which is nearly straight-sided, with a lip slightly bell-shaped; and a plain round stem without a knob, swelling out into the bowl and into a plain foot which ends in a round moulding and flat edge.

(a)

SILVER FLAGON. Weight 22.9 oz. Height $8\frac{1}{2}$ in. Diam. at the top $3\frac{1}{2}$ in.; at the foot $5\frac{1}{4}$ in. Date 1730.

Hall marks. 1. Capital Roman P in a plain shield. 2. Leopard's head crowned in a plain shield. 3. Lion passant in a plain oblong. 4. Capital Roman M, a mullet above and below, within a circle.

This is a small straight-sided flagon, narrowing towards the top, having a round top to its lid. In front is, "*Deo et ecclesie de Appleby proprium fecit Vir qui esse bonus quam videri maluit.*"*

(b)

SILVER PATEN with a foot. Weight 13 oz. Diam. 8 in. Diam. of foot $3\frac{1}{2}$ in. Height of foot $1\frac{3}{4}$ in. Date 1868.

London hall marks.

This is a plain, solid paten, with the sacred monogram within an ornamental circle in the centre. Underneath is, "*Deo et Ecclesie de Appleby grato animo sacrum fecit Johannes Manuel Echalez, A.M., anno quadragesimo septimo ex quo Rector Factus est, A.D. Mdcccclxxvi.*"†

* "A man who wished to be, rather than to seem, good, made this over to God and the church of Appleby."
 † "To God and the church of Appleby, John Manuel Echalez, A.M., dedicated this with a thankful heart in the forty-seventh year of his incumbency."

SILVER PLATE. Weight 10.1 oz. Diam. 8 in. Date 1866.

London hall marks.

This is the same in shape as the paten, without the foot. Underneath is, "*Ecclesie de Appleby proprium fecit Johannes Manuel Echalar, A.M., Rector. A.D. mdccclxxvi.*"

THREE PEWTER PLATES. Diam. of each 8½ in.

Marks. 1. On an ornamental shield within an oval, per chevron engrailed three leopards' faces. 2. On a scroll, "London."

(a)

The flagon was, according to *Nichols* (Vol. iv., p. 433), the gift of the Rev. **Samuel Martin**, M.A., who was Latin master of the Free School of Appleby; which had been built and endowed by Sir **John Moore**, Kt., alderman of London in 1697, the building having been designed by Sir **C. Wren**.* Mr. **Martin** was the son of the Rev. **Samuel Martin**, master of the Free School, Loughborough, from 1698 till his death in 1748, by his wife **Elizabeth Crumpton**, who died in 1713.† **Samuel Martin**, jun., was baptized at Loughborough on the 5th of Sep., 1701,‡ and was educated in his father's school. On the 10th of March, 1718-19, he matriculated as a servitor in Lincoln College, Oxford, from whence he took his B.A. in 1722 and his M.A. in 1725. On 19th April, 1723, he and several others were elected fellows of Oriel College, but Provost **Carter** refused his assent to their election; consequently legal proceedings were taken by Mr. **Martin** and the rest, which were eventually successful; but not until after considerable delay, they only being admitted to their fellowships in 1727; Mr. **Martin** retained his fellowship at Oriel but for a very short time; he vacating it on 7th April, 1730, owing to his having been appointed to the "uberius beneficium"§ of Newton Regis. He had been elected to the Latin mastership of Appleby School, as soon as he had taken his M.A. degree in 1725. In 1729 he was appointed to the living of Newton Regis in the county of Warwick; which he held, together, with his mastership, till 1738, when he resigned the latter.||

Mr. **Martin** remained at Newton Regis till 1746, when he was appointed to the Rectory of Gotham, Notts, of which he was incumbent until his death on Christmas Day 1775.

Near the chancel arch of Gotham church is a mural tablet of slate to his memory, inscribed with a long epitaph in Latin; which, if it speaks the truth, bears witness in the following words to Mr. **Martin's** life having agreed with his ideal expressed on the flagon; "*Agnoscas, Lector, viri eximiam Pietatem et Mores apprime spectatos.*"¶ While he was at Newton Regis Mr. **Martin** was married there on 14th Oct., 1741, to **Anne**, second daughter of Mr. **John Hunter**, Master of Lichfield Grammar School, who bore him two children, **Samuel** and **Anne**.**

* For some letters relating to which see *Hist. MSS. Commis.*, Report x., part iv., p. 137. † Married at Loughborough on 20th Aug., 1700. ‡ Parish Register. § Kindly communicated by the Librarian of Oriel Coll., Oxon. || It was at this vacancy that Samuel Johnson made the unsuccessful application for the mastership. ¶ "Know, reader, the exceeding piety and thoroughly approved morals of the man." ** Parish Register.

(b)

The Rev. **John Manuel Echalaz**, J.P., was the son of **Joseph Echalaz**, of Clapton, Middlesex, and matriculated at Trinity Coll., Oxford, at the age of 17, on 1st April, 1818, and took his B.A. and M.A. degrees from thence in 1822 and 1824. From 1829 to 1830 he was a fellow of his college, becoming in the latter year rector of Appleby; and here he stayed till his death on 16th May, 1877. Mr. **Echalaz** was for many years rural dean of Sparkenhoe, and was made in 1844 an honorary canon of Peterborough. He married on 13th Dec., 1832, **Charlotte**, youngest daughter of **Richard Lloyd**, of Allesley, co. Warwick,* which lady died at Netherwood, Godalming, on 29th Oct., 1880, aged 75, and was buried next her husband in this churchyard, where a marble cross marks their graves; their memory is also recorded by a window filled with painted glass on the South side of the chancel. Mr. and Mrs. **Echalaz** had several children; their eldest son, **John George**, was baptized in this parish on 16th Jan., 1834.

COALVILLE.

SILVER CUP. Weight 9.8 oz. Height $8\frac{1}{2}$ in. Diam. of the bowl $3\frac{7}{8}$ in.; of the foot $3\frac{3}{8}$ in. Height of the stem $4\frac{1}{4}$ in. Date **1839**.

London hall marks.

This cup has a straight-sided concave bowl rounded off below, with a raised moulding round its lip. It has a thin stem swelling out into a round knob, and a plain foot, round which is: "*Presented by the Rev. F. Merewether, Vicar of Whitwick, to Christ Church, Coalville, Augt 4, 1840.*" On the bowl is the sacred monogram with a cross and three nails, within a circle of glory.

SILVER PATEN with a foot. Weight 9.2 oz. Diam. 7 in. Diam. of the foot $3\frac{3}{8}$ in. Height of the foot $1\frac{1}{8}$ in. Date **1840**.

London hall marks.

This is a plain paten with a flat edge, round which is the same inscription as that on the cup. In the centre is the sacred monogram with a cross and three nails, within a circle of glory.

SILVER PLATED FLAGON. Height 13 in. Diam. at the top $4\frac{3}{8}$ in.; at the foot 6 in.

This is a tall straight-sided flagon narrowing towards the top. In front is the sacred monogram with a cross and three nails, within a circle of glory.

SILVER PLATED PLATE. Diam. $9\frac{1}{2}$ in.

This is a plain basin-shaped plate.

The silver cup and paten were presented to this church at the time when it was built, the donor being one of the principal subscribers to the building fund of the church. A portion of the ecclesiastical district of Coalville was originally in Mr. **Merewether's**† parish of Whitwick.

* For pedigree of Lloyd of Allesley, see *Our Noble and Gentle Families*, J. Foster, 1885; p. 148. † See Whitwick, p. 33.

CONGERSTONE.

SILVER CUP WITH A COVER. Weight of cup 10 oz. Height $7\frac{1}{4}$ in. Diam. of the bowl and of foot $3\frac{7}{8}$ in. Height of stem 4 in. Date *circa* 1660. (PLATE 33.)

On the bowl is the maker's mark only, repeated four times: viz., B, with a pellet above, below, and on each side, within an oblong with the corners clipped.

The bowl of this cup is shaped into an inverted truncated cone, rounded off into a flat base. It rests upon a baluster stem rising out of a flat sloping foot. Underneath the latter is the lion passant within a shaped oblong. The maker's mark was plainly stamped upon the bowl four times by mistake.

SILVER COVER. Weight 2.5 oz. Diam. $3\frac{3}{8}$ in. Date *circa* 1660. (PLATE 33.)

The same maker's mark stamped once.

This is a conical-shaped cover with a rim round its edge to cause it to fit on to the cup. It is surmounted by a round knob, and round the edge on the outside is a small cable moulding.

(a)

SILVER PATEN with a foot. Weight 14.4 oz. Diam. 9 in. Diam. of foot $3\frac{3}{4}$ in. Height of foot $2\frac{5}{8}$ in. Date 1718.

Hall marks. 1. Capital Roman C in a plain shield. 2. Britannia. 3. Lion's head erased. 4. S. P., a pellet between the letters, two pellets and a rose above, a bird below, within a plain shield; the mark of *William Spackman*.

This is a flat paten with a raised edge. The foot is a hollow drum swelling out into a round moulding and a flat edge. Round the centre of the paten is: "*The gift of Mrs. Felicia Jennens, to the church of Congeston, 1718.*"

(b)

SILVER CUP. Weight 11.6 oz. Height 8 in. Diam. of the bowl and of the foot $3\frac{1}{2}$ in. Height of the stem $4\frac{3}{4}$ in. Date 1840.

London hall marks.

This cup has a straight-sided bowl, gilt inside: a baluster stem and a foot shaped into six lobes. Upon the bowl is engraved the sacred monogram with a cross above and three nails below, within a circle of glory. On the foot is "A. R." in a monogram with a crown above; below is: "*To Congerstone Church. August, 1840.*"

SILVER CUP. Weight 11.3 oz.

This cup is in all respects like the last.

SILVER PATEN with a foot. Weight 16.2 oz. Diam. $7\frac{1}{2}$ in. Diam. of the foot $3\frac{1}{2}$ in. Height of the stem 2 in. Date 1840.

This paten is hexagonal in shape, having in its centre the sacred monogram with a cross and three nails, within a circle of glory. Underneath the foot is the same inscription as that on the cups.

TWO SILVER DISHES. Weight of each 21 oz. Diam. 10 in. Date 1840.

These are plain and massive dishes. In the centre of each is the sacred monogram, with a cross and three nails, within a circle of glory. Underneath each is the monogram "A. R." surmounted by a crown, and "*To Congerstone Church. August, 1840.*"

SILVER FLAGON. Weight 42.4 oz. Height 10½ in. Diam. at the top 3⅞ in.; at the foot 6⅝ in. Date 1840.

This is a straight-sided flagon narrowing towards the top, having a large hexagonal-shaped foot. In front is the sacred monogram with a cross and three nails, within a circle of glory. Upon the foot in front is: "A. R." with a crown above, and the same inscription as that on the cups.

PEWTER FLAGON. Height 7¾ in. Diam. at the top 3⅝ in.; at the foot 3⅜ in. Marks. W. R. with a crown above.

This is a tankard-shaped flagon thickly made, with a flat top to its lid.

(a)

The donor of the first paten was the youngest daughter but one of Mr. **Humphrey Jennens**, of Erdington hall, Birmingham, by **Mary**, daughter of Col. **Milward**, of Snitterton, Derbyshire. She was born in about 1668, and died unmarried early in 1744. Miss **Felicia Jennens** was in her life-time a benefactress to the Blue Coat school, Birmingham, towards the building of which in 1724, she gave £300. She was the sister of Mr. **Charles Jennens**,* and as she was unmarried, perhaps lived with her brother at Gopsal, after the death of his second wife in 1708.

In her will dated 25th July, 1739, and proved 24th April, 1744, P.C.C., she left £1000 to the charity for the maintenance of incurables at Westminster Infirmary; and £1000 in trust for the benefit either of the Blue Coat school, Birmingham, or another charity in that town that the trustees might prefer. She desired to be buried at Whitacre, co. Warwick, to the poor of which place she left £5; but there is no entry of her burial in the register of that parish, nor any monument to her memory in the church.

(b)

The royal cypher betokens the modern service of communion plate to have been the gift of Queen **Adelaide**. Her Majesty, who was born on 13th August, 1792, being the eldest daughter of **George**, reigning Duke of **Saxe Meiningen**, was married to King **William IV.**, when Duke of **Clarence**, on 11th June, 1818, and crowned with him at Westminster, on 8th Sep., 1831. After the death of the King, the Queen Dowager paid several visits to this county, honouring Gopsal especially with her presence, the seat of her Lord Chamberlain, **Richard William Penn**, 1st Earl **Howe**.† During one of these visits paid early in August, 1840, Her Majesty attended a service at Congerstone church, at which a sermon was preached by the then rector, the Rev. **F. M. Knowles**, M.A., in aid of a fund which was being raised for various improvements in connection with the fabric and utensils of the church. The Queen Dowager contributed to the offertory a sum of money with the wish that it should be devoted to the purchase of this service of

* *Vide* Twycross, *infra*. † See *Royal Progresses and Visits to Leicester*, by William Kelly, F.S.A., F.R.H.S., p. 506, for much interesting matter in connection with these visits.

communion plate : one of many acts of kindness performed by this charitable and amiable lady. The esteem in which the name of Queen **Adelaide** has for many years been held by Englishmen, is well reflected in these two quotations.

“Her memory obtained that respect which purity, goodness, and unpretending piety in a high station are sure sooner or later to command; and the justice which had been denied her during a large portion of her husband’s reign was fully accorded to her after his death.”*

Extract from a letter written by Queen **Victoria** to King **Leopold**.

“Osborne, Dec. 4th, 1849.

“You know how very kind she was at all times to me, and how admirably she behaved from the time the King died. She was truly motherly in her kindness to us and to our children, and it always made her happy to be with us and to see us. She is a great loss to us both, and an irreparable one to hundreds and hundreds. She is universally regretted.”†

Queen **Adelaide** died on 2nd Dec., 1849, and was buried, by her own request very quietly without any lying in state, at Windsor.

FENNY DRAYTON.

SILVER CUP AND COVER PATEN. Weight of cup 17.3 oz., including lead in the stem. Height $7\frac{1}{4}$ in. Diam. of bowl $3\frac{5}{8}$ in.; of the foot 3 in. Height of stem $2\frac{3}{4}$ in. Date **1598**. (PLATE 32.)

There are no hall marks on either the cup or its cover.

This cup has a deep bowl shaped into an inverted truncated cone, with its lip slightly bell-shaped, and with a flat base having a projecting edge round which run a few lines. Round the bowl is a band of stroke ornament divided into three parts by hour-glass curves. At the top of the stem is a narrow neck, round which is a lozenge-shaped ornament, below this is a disk $1\frac{1}{8}$ in. in diameter, divided into sixteen parts by radii, every other one being ornamented at the top with zigzag lines. Below the disk the stem swells out gradually into a narrow vertical edge round which is a reed ornament. The foot is of the usual shape with a reed ornament running round its edge; on the top it has a band of stroke ornament similar to that round the bowl. Below the foot are the initials “R + P + R + M.”

SILVER COVER PATEN with a foot. Weight 2.3 oz. Diam. $4\frac{1}{8}$ in. Diam. of the foot $1\frac{3}{8}$ in. Height of foot $\frac{7}{8}$ in. Date **1598**. (PLATE 32.)

This paten, which is of the usual shape, has round its top a band just the same as that round the bowl of the cup. The foot is a disk attached to the paten by a stem swelling out at both ends. On the foot is “THE PARISHE OF DRAETON, 1598.”

SILVER ELECTRO-PLATED FLAGON. Height $10\frac{3}{8}$ in. Diam. at the top 2 in.; at the foot $3\frac{3}{8}$ in.

This is a plain jug-shaped flagon.

* *The History of England from 1830—1874*, by W. N. Molesworth, M.A. Vol. ii., p. 325. † *The Life of His Royal Highness the Prince Consort*, by Sir T. Martin, Vol. ii., p. 234, 6th Ed.

SILVER PLATED DISH. Diam. 6 in.

In the centre of this dish is the sacred monogram within a circle of glory.

The initials "R P and R M" on the foot of the cup probably represent the names of the churchwardens in office in 1598; one of whom may have been **Ralph Purefoy**, a member of an ancient and distinguished family which had been up to that time settled in this parish for more than two hundred years, and remained here until early in the eighteenth century.*

The silver plated flagon was given a few years ago by Mr. **Rowland Robnison**, a resident in this parish.

HEATHER.

SILVER CUP. Weight 5.4 oz. Height $5\frac{3}{8}$ in. Diam. of the bowl $3\frac{1}{2}$ in.; of the foot $3\frac{1}{4}$ in. Height of stem 2 in. Date *circa* 1575.

Mark. A rose.

This cup has a bowl shaped into an inverted truncated cone, concave, with a flat projecting base with a small moulding round its edge. Round the upper part of the bowl is a band of stroke ornament $\frac{3}{8}$ of an inch wide, divided into six parts by hour-glass curves, each part being divided in half by a horizontal strap. The stem is a narrow evenly-balanced one, being divided in half by a small round moulding between two lines for a knob, from whence it swells out to each end: at the upper end is a vertical edge with lines running round; the lower vertical edge has been taken out at some former time when the cup has been repaired. The foot is flat at the top, and ends in the usual vertical and flat edges.

SILVER PATEN. Weight 1.6 oz. Diam. $4\frac{1}{8}$ in. Date *circa* 1575.

No marks.

This paten fits on to the cup, and is to all appearance of the same date. It has a flat edge $\frac{3}{8}$ of an inch wide from which the middle part is sunk into a shallow round. It seems never to have been a cover, but simply a paten.

PEWTER PLATE. Diam. $8\frac{1}{2}$ in.

Marks. 1. Rose crowned. 2. "London" in a shaped oblong.

PEWTER BASIN. Diam. $9\frac{1}{4}$ in. Depth $2\frac{1}{2}$ in.

Marks. 1. Seeded rose between two sprays of foliage crowned. 2. "London" on a scroll.

HUGGLESCOTE.

SILVER CUP. Weight 5.2 oz. Height 6 in. Diam. of the bowl $3\frac{5}{8}$ in.; of the foot 3 in. Height of stem $2\frac{3}{4}$ in. Date *circa* 1575. (PLATE 30.)

No marks.

This cup which to all appearance belongs to the "rose" series, has a bowl shaped into an inverted truncated cone, with concave sides and a bell-shaped lip: its base is flat and

* For pedigree see *Nichols*, Vol. iv., p. 599. Parish Register begins in 1709.

projecting with a few lines running round the edge. Round the bowl is a band of Elizabethan foliage divided into eight parts by hour-glass curves, every other one having an additional twist in it. The stem is evenly balanced, being divided in half by a small round between two hollow mouldings for a knob, from whence it swells out into reeded ends. The foot which is flat at the top, ends in a vertical and flat edge, a reed ornament running round the former. The bowl has had a new bottom put to it in recent years.

SILVER PATEN. Weight 4.8 oz. Diam. 7 in. Date 1876.

London hall marks.

This is a perfectly plain paten with a wide flat edge, the middle part being sunk flat.

GLASS FLAGON WITH SILVER MOUNTINGS. Height $9\frac{1}{2}$ in. Diam. at the top $2\frac{1}{2}$ in.; at the foot $3\frac{1}{2}$ in. Date 1876.

London hall marks.

This is a plain jug-shaped flagon with a quatrefoil-shaped lip. It has a silver lid surmounted by a cross within a quatrefoil, and a silver handle.

PEWTER BASIN. Diam. $7\frac{7}{8}$ in. Depth $2\frac{1}{4}$ in.

No marks.

This is a plain-shaped basin with its edge turned outwards.

TWO PEWTER PLATES. Diam. of each $10\frac{1}{2}$ in. Date *circa* 1800.

Marks. 1. X crowned repeated twice. 2. Two cocks facing each other, "Cocks" above in old English letters, and "London" below. 3. In four small shapes; (a) Lion passant. (b) Leopard's face. (c) Illegible. (d) S. C.

The silver cup formerly belonged either to Ibstock or Donington churches: the latter was pulled down at the end of the last century, when with the help of the old materials, a church was built in Hugglescote, which was replaced in 1878 by the present building, erected by subscription on a different site.

It is not altogether impossible but what this ancient communion cup may have been used by Archbishop Laud, who was inducted to the living of Ibstock, to which Donington is a chapelry, on 2nd Aug., 1617. He officiated at any rate twice at Ibstock as is shown by these entries in his diary; "1624, July 23, Friday. I went to lie and keep house, and preach at my livings held 'in commendam' Creeke and Ibstock." "Aug. 8, Sunday. I went and preached at my parsonage at Ibstock, and set things in order there."

The modern silver paten and glass flagon were presented by some members of the congregation shortly before the new church was built.

IBSTOCK.

SILVER CUP. Weight 20.4 oz. Height $7\frac{1}{4}$ in. Diam. of the bowl $4\frac{3}{4}$ in.: of the foot 4 in. Height of stem $2\frac{1}{4}$ in. Date 1802.

London hall marks.

This is a two handled cup, with a deep egg-shaped bowl standing upon a short round stem which swells into a plain foot. On one side of the bowl is: "*Drink ye all of it.* MATT. xxvi., 28;" on the other "*Ibstock Church, 1818.*"

SILVER PATEN. Weight 8 oz. Diam. 7 in. Date 1823.

London hall marks.

This is a plain paten with this inscription in its centre: "*William Madan, Curate of Ibstock, 1818.*"

TWO SILVER ELECTRO-PLATED PLATES. Diam. of each 9 in.

These are quite plain; each having this inscription underneath: "*St. Dennis Church, Ibstock, 1854.*"

PEWTER PLATE. Diam. 9 in. Date *circa* 1698.

Marks. 1. "London" in a shaped oblong. 2. Rose crowned, "London" above. 3. A lily rising out of a plough, illegible name above. 4. "Ibstock."

PEWTER PLATE. Diam. 10 $\frac{1}{4}$ in. Date *circa* 1800.

Marks. 1. X crowned repeated twice. 2. Two cocks facing each other, "Cocks" in old English capitals above, "London" below; within an oval. 3. In four squares with the corners clipped: (a) Lion passant. (b) Leopard's face. (c) Square buckle. (d) S. C.

Both plates are quite plain in shape.

The silver cup was given to this parish by the Rev. **Spencer Madan**, D.D., the eldest son of the Right Rev. **Spencer Madan**, Bishop of **Peterborough** from 1794 to 1813, by Lady **Charlotte Cornwallis**, second daughter of **Charles**, 1st Earl **Cornwallis**. Dr. **Madan** was born in 1758, and was elected a King's scholar at Westminster at the age of 13: graduating from Trinity College, Cambridge, he took his M.A. degree in 1779, and was made D.D. in 1809. He was presented to this living, together with Donington and Hugglescote in 1786, and also to the rectory of St. Philip's, Birmingham, in the year following: in the succeeding year he became a chaplain to King **George III**. It was while he was rector of St. Philip's, Birmingham, that Dr. **Madan** took a prominent part in the controversy raised by certain churchmen with Dr. **Priestley**, his principal share in which was, "A letter to Dr. **Priestley**," written in 1787: a sermon preached two years later, entitled "The principal claims of dissenters considered," and another letter printed in 1790. Dr. **Priestley** had a great opinion of his opponent, and considered him to be "the most respectable clergyman in the town."* Dr. **Madan** was preferred to a canonry in Lichfield cathedral in 1790, to the chancellorship of the diocese of Peterborough in 1794, and to a prebendal stall in that cathedral in 1800. In 1809 he resigned his canonry at Lichfield, and his living in Birmingham, upon being presented by his brother-in-law, **William Phillips Inge**, Esq., to the rectory of Thorpe Constantine, Staffs, which he resigned in 1824 in favour of the late rector, remaining rector of Ibstock until the day of his death, 9th Oct., 1836.

* See *Life of Dr. Priestley*, by J. T. Rutt.

The doctor translated "Grotius de Veritate," and published several sermons.* His name is recorded on a white marble tablet, on the North wall of the chancel of Ibstock church, opposite to a tablet placed by himself to the memory of his faithful servant **Sarah Jackson**. His own memorial speaks of him as having been "a preacher able, eloquent, impressive, a pastor zealous, bountiful, affectionate."

He married on 5th Jan., 1791, **Henrietta**, daughter of **William Inge**, Esq., of Thorpe Constantine, which lady bore him a numerous family, and died on 24th June, 1816, being buried at Thorpe Constantine.

The silver paten was given to this church by Dr. **Madan** in memory of his second son, **William**, who was born in 1793, and was a student of Christ Church, Oxford, from whence he took his B.A. degree with distinction in 1814; and M.A. in 1817. He became curate to his father at Ibstock in 1818, holding this post until August in the year following, when he was appointed to the vicarage of Polesworth, co. Warwick, where he remained until his early death on 17th April, 1824. Mr. **Madan**, who died unmarried, was much beloved by his parishioners; who placed to his memory in their church a white marble tablet, now in the vestry; on which they have borne witness to his benevolence, unassuming manner, zeal and piety. Mr. **W. Madan** left the sum of £100, the interest from which he desired to be spent in the purchase of bibles for Polesworth church.

NAILSTONE.

SILVER CUP AND COVER PATEN. Weight of cup 5.1 oz. Height $5\frac{1}{2}$ in. Diam. of bowl $3\frac{3}{4}$ in.; of foot 3 in. Height of stem $2\frac{1}{2}$ in. Date *circa* 1575. (FIG. 45.)

Mark. A rose.

This cup is very similar to all others of this series except in its stem, which is inclined to be baluster in shape like the stem of the Isley Walton cup,† the disks at the top and bottom are divided into many parts by radii. Round the bowl, above the middle, is a band of stroke ornament divided into eight parts by hour-glass curves;‡ the band being bisected by a horizontal strap.

SILVER COVER PATEN with a foot. Weight 1.8 oz. Diam. 4 in. Diam. of foot 1 in. Height $\frac{5}{8}$ in. Date *circa* 1575. (FIG. 45.)

No marks.

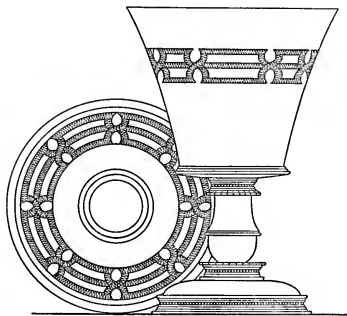

Fig. 45. *Circa* 1575. $\frac{1}{2}$ of full size.

* For a list of which see *Nichols*, Vol. iv., p. 753. † Page 42, Plate 4. ‡ Strokes omitted by mistake in the figure

This paten has a narrow, flat, edge, on which is the usual rim. The middle part is sunk in a flat round shape. Round the top is an engraved band of stroke ornament exactly like that on the cup. The foot is a disk attached to the paten by a stem swelling out at both ends.

SILVER FLAGON. Weight 32.7 oz. Height 10 in. Diam. at the top 4 in; at foot $6\frac{1}{4}$ in. Date 1763.

Hall marks. 1. Capital old English H in a square shield. 2. Leopard's head crowned in a rounded shield. 3. Lion passant in a plain oblong. 4. I. M. a mullet of six points between the letters in a plain oblong; mark of *Jacob Marsh*.

This is a straight-sided flagon narrowing to the top, having a round top to its lid and an R-shaped handle. In front is the sacred monogram, with a cross above and three nails below, within a circle of glory. On the top of the foot is; "*Given to the Church at Nailston. A.D. 1763. R B Rr.*"

TWO PEWTER PLATES. Diam. $9\frac{3}{4}$ in.

Marks. 1. X crowned. 2. Out of a ducal crown, a horse's jamb. 3. "London." 4. In four small shapes: (a) S. D. (b) Talbot's head erased. (c) Horse's jamb. (d) Per chevron engrailed three talbots' heads.

R. B., the donor of the silver flagon to this church, was the Rev. **Richard Bentley**, D.D.; who was the son of **Joseph Bentley**, of Yorkshire, and was born in 1704. The great Dr. **Bentley**, was his uncle, and probably also god-father and guardian, for **Joseph Bentley** died before his son left school. **Richard Bentley** was sent to Wakefield Grammar School as his uncle had been before him, and at the age of 17 was entered on 23rd Sept., 1721, at Trinity College, Cambridge, of which the Doctor had already been master for twenty-one years. He took his B.A. degree in 1725, and was made a junior fellow of his college in 1728: in the year following he took his M.A., and became a senior fellow.* He was the constant companion of his uncle, whom he assisted much in his literary work, being of especial service to him in connection with the new edition of the Greek Testament, which the great critic had thoughts at one time of bringing out; he travelled at his expense through Europe, in order to examine and collate all the MSS. of the Greek Testament that were accessible. His connection with this parish began in 1745, when he was made rector of Nailstone and Normanton, through the influence of the Duke of **Newcastle**, this being a crown living. In 1750 he proceeded to the degree of D.D., "per Lit. Reg." Dr. **Bentley**, who resided regularly at Nailstone during the latter years of his life, died unmarried on 4th March, 1786. Over his grave in this churchyard at the North-east end of the church is a headstone, on which is a short inscription written by himself two years before his death.† Dr. **R. Bentley** inherited from his uncle his MS. critical edition of the Greek Testament; which he in turn left to Trin. Coll., Cambridge, where it now is.

* Registers of Trin. Coll.

† *Nichols*, Vol. iv., p. 809.

NEWBOLD VERDON.

SILVER CUP AND COVER PATEN. Weight of cup 4.7 oz. Height $4\frac{3}{8}$ in. Diam. of the bowl $3\frac{1}{4}$ in.; of foot 3 in. Height of stem $1\frac{1}{2}$ in. Date 1698. (PLATE 29.)

Hall marks. 1. Court-hand C. 2. Lion's head erased. 3. Britannia. 4. V. N. in a heart-shaped shield.

This is a pretty little cup with a fluted bowl and a short, straight, stem, which has at the top and also in the middle, a small round moulding on a fillet. The foot is flat and has a gadrooned edge under which the lion's head erased is repeated.

SILVER COVER PATEN. Weight 1.6 oz. Diam. 4 in. Date 1698. (PLATE 29.)

Hall marks as on the cup.

This paten has a flat edge from which the main part is sunk quite flat. On the top is a handle formed by a thin band of silver $\frac{5}{8}$ in. wide, turned round into a flat loop, meeting at the two ends. There is a fluted cup like this, but having a more elaborate cover, at Mosterton, Dorset.*

SILVER CUP. Weight 11.4 oz. Height $7\frac{7}{8}$ in. Diam. of the bowl and of the foot $3\frac{3}{4}$ in. Height of stem $3\frac{1}{2}$ in. Date 1704. (PLATE 29.)

Hall marks. 1. Court-hand I. 2. Lion's head erased. 3. Leopard's head crowned. 4. G. A., a crown between two annulets above, a pellet below, within a dotted circle, the mark of *William Gamble*.

This cup has a bowl shaped into an inverted truncated cone with a lip slightly bell-shaped, and a short baluster stem swelling into a plain flat foot, rounded off at the edge, the lion's head being repeated underneath.

SILVER PATEN. Weight 4.9 oz. Diam. $6\frac{1}{4}$ in. Date 1704. (PLATE 29.)

Hall marks as on last cup.

This paten has a flat edge $\frac{5}{8}$ in. wide, the middle part being sunk flat $\frac{1}{8}$ in. deep.

SILVER FLAGON. Weight 22.4 oz. Height $9\frac{1}{4}$ in. Diam. at top $3\frac{1}{2}$ in.; at the foot $4\frac{3}{8}$ in. Date 1704. (PLATE 30.)

Hall marks as on last cup.

This flagon is a little different to others in having a barrel-shaped drum and in consequence a narrower foot than usual; this is a defect, for when the lid is opened back on to the handle the flagon is inclined to be top-heavy.

SILVER CUP. Weight 11.5 oz. Height $8\frac{1}{8}$ in. Diam. of bowl $3\frac{3}{8}$ in.; of foot $4\frac{5}{8}$ in. Height of stem $3\frac{5}{8}$ in. Date 1705.

Hall marks. 1. Court-hand K. 2, 3, and 4, as on last cup.

This cup has a rather narrower bowl and a wider foot than the last one; otherwise they are both much the same in shape.

SILVER PATEN. Weight 4.5 oz. Diam. $6\frac{1}{8}$ in. Date 1705.

Hall marks as on last cup.

This paten has a flat sloping edge $\frac{1}{2}$ in. wide, the middle part being sunk flat $\frac{1}{4}$ in. deep.

* *Church Plate of Dorset*, p. 46, by J. E. Nightingale, F.S.A., 1889.

SILVER FLAGON. Weight 23.2 oz. Height $9\frac{1}{4}$ in. Diam. at the top $3\frac{3}{8}$ in.; at foot $4\frac{3}{8}$ in. Date 1705.

Hall marks as on last cup.

The flagon is much the same in shape as the other. Its drum is rather narrower. Its lid has a flat top with a projecting edge. It has a large round handle and an ornamental purchase.

SILVER PLATE. Weight 18 oz. Diam. $9\frac{1}{2}$ in. Date 1707.

Hall marks. 1. Court hand M. 2, 3, and 4 as on last cup.

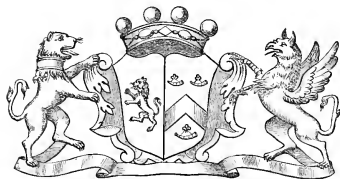

Fig. 46.

This is a plain thick plate, formerly a dinner plate, with a flat edge $1\frac{1}{2}$ in. wide, the middle part being sunk flat $\frac{1}{4}$ in. deep. On the edge is this coat of arms, *Azure, a lion rampant Argent; Crewe; impaling Argent, a chevron Vert between three hunting horns Sable strung Gules; Foster.* Supporters, *Dexter; a lion Argent, gorged with a ducal coronet Or; Sinister; a griffin Sable.* Above the shield is a baron's coronet. (FIG. 46.)

This silver plate was bequeathed to this church by **Nathaniel, Lord Crewe**, Bishop of **Durham**, in a codicil dated 17th Sep., 1721, attached to his will made on 24th June, 1720, and proved P.C.C. on 3rd March, 1721-2, in these words; "*I give one of my silver plates, such a one as I have given to Steane chappell, for the use of the altar at Newbold.*" There is very little doubt but what the Bishop gave during his life-time the rest of this communion service, with the exception perhaps of the little cup and cover. It will be noticed that all the pieces except that, were made by the same maker as the one who supplied the Bishop with plate for his own house. There was no one else connected with the parish at that time who could afford to make an offering of such value to the church. One would like to think that the little covered cup may have once belonged to the Bishop, and been used by him in private celebrations of the holy communion.

Nathaniel, Lord Crewe, was the fifth son of **John, 1st Baron Crewe**, by **Jemima**, daughter and co-heir of **Edward Walgrave**, and was born on 31st Jan., 1633, at Stene, Northants. On 2nd Feb., 1651-2, he was admitted to Gray's Inn,* and in Sep. of the same year was sent to Lincoln College, Oxford, of which society owing to his good scholarship, he soon became a distinguished member. Having taken his B.A. degree in 1655, he was in 1656 elected a fellow: he took his M.A. degree in 1658, and became a sub-rector of his college the year following, and finally rector in 1668. It was his good fortune to be senior proctor in 1663, when **Charles II.** paid a visit

* *Gray's Inn Admission Register.* Edited by J. Foster, 1889.

to the University. As the holder of that office, the sub-rector of Lincoln had to receive the King in the public library, and deliver into his hands the black rod, which he did on his knees, repeating these words, "*ne vel una macula nigriorem,*" thereby gaining much applause both from the King and the University. In 1665 **Nathaniel Crewe** was ordained deacon and priest on the same day, by **Morley**, Bishop of **Winchester**, and in the same year made a chaplain to the King. His promotion in the church was not long delayed; he was made successively, Precentor of **Chichester**, in 1669: Bishop of **Oxford**, in 1671: Bishop of **Durham**, in 1674: Dean of the Chapel Royal, in 1684. It was when **N. Crewe** was translated to Durham, that **Charles II.** returned the witty answer to some who objected to the new Bishop's youth; "he would mend of that every day." In the state, as in the church, the Bishop occupied an important position, especially at the time when his patron, the Duke of **York**, ascended the throne as **James II.** During that reign, the Bishop of **Durham**, was one of the principal men who too readily assisted the King in carrying out his arbitrary measures. He was one of the seven commissioners of the Court of High Commission, appointed for inspecting Ecclesiastical affairs, and in the transactions of that commission cannot be accused of having been merely a sleeping partner. After the abdication of his master, the Bishop's share in the control of the state was taken away from him, and his Court influence during the Orange dynasty was naturally nil. Several of his lay posts, and much of the patronage belonging to him in right of his See, were withdrawn from him. These however were in part restored during the reign of Queen **Anne**, who caused him to be welcomed once more to the Court, she herself holding him in high estimation. The Bishop of **Durham** having lived to see the first **George** for several years in occupation of the throne, died at Stene, on 18th Sep., 1722, at the age of 88, and was buried there on 30th Sep. Wealth and liberality are associated with the name of Bishop **Crewe**; his private fortune was very large; according to **Pepys**,* he had an estate worth from £600 to £700 a year left him in 1666 by a friend: in 1681 he inherited the Newbold Verdon estates from his brother **John**; and in 1697, succeeded to all the family estates at Stene and elsewhere, together with the title, at the death of his elder brother, **Thomas**, 2nd Lord **Crewe**; and his second marriage brought him further wealth. The income which he derived from all these estates, as well as that from his church preferments, was spent with the utmost liberality and hospitality: "I will leave it to one that will make the chimnies smoke," were the words of his brother upon bequeathing to him the **Crewe** estates

* *Diary*, Chandos Library, p. 350.

in this parish. In the pulpit the Bishop was excellent: here is what the sermon-loving **Pepys** thought of him as a preacher; "Dr. **Crewe** did make a pretty, neat, sober, honest sermon; and delivered it very readily, decently, and gravely, beyond his years; so as I was exceedingly taken with it, and I believe the whole chapel."* The Bishop was twice married; first on 21st Dec., 1691, to **Penelope**, daughter of Sir **Philip Frowde**, Knt., and widow of Sir **Philip Tynt**, who died on 9th March, 1699, aged 44, and was buried at Stene: secondly on 23rd July, 1700, at Durham, to **Dorothy**, youngest daughter of Sir **William Foster**, of Bamborough, Knt., and co-heir of her brother **William**, which lady died on 16th Oct., 1715, aged 42, and was buried at Stene, where there is a monument erected by the Bishop, to his own, and his second wife's memory; over the grave of his first wife is an inscribed slab.†

The Bishop having had no issue by either wife, the family estates of Stene passed by entail to the Duke of **Kent**, who had married **Jemima**, daughter of his eldest brother, **Thomas**, 2nd Lord **Crewe**. His property at Newbold Verdon he gave by deed shortly before his death to **James**, eldest son of his nephew, the Hon. **Charles Montague**, from whom it passed to **Edward**, husband of Lady **Mary Wortley Montague**, whose son, **Edward**, sold it in about 1764. The Bishop's second wife, **Dorothy**, was co-heir with her nephew, **Thomas**,‡ whose father, **Thomas Forster**, of Adderstone, had married her eldest sister, **Frances**, in the estates of Bamborough and Blancheland, owing to all her brothers having died without issue.§ In 1704, those estates were sold by order of the court of Chancery, and bought by the Bishop for £20,679,|| who bequeathed them to trustees for the benefit of a large number of specified charities, amongst which he assigned £20 a year for a schoolmaster in this parish, and £10 a year to the widows and orphans of clergy in the deanery of Sparkenhoe.¶

NORMANTON-LE-HEATH.

SILVER CUP. Weight 12.8 oz. Height $7\frac{3}{4}$ in. Diam. of the bowl $3\frac{7}{8}$ in.; of the foot $3\frac{3}{8}$ in. Height of stem $3\frac{3}{4}$ in. Date 1747.

Hall marks. 1. Small Roman M in a shaped shield. 2. Leopard's head crowned in a rounded shield. 3. Lion passant in a plain oblong. 4. T. R. G. C. in script letters: the mark of *Gurney & Co.*

This cup has a straight-sided concave bowl, standing on a plain stem and foot. On the bowl is the sacred monogram with a cross and three nails, within a circle of glory, and "*The gift of Edward Green, to the church at Normanton, 1747.*"

SILVER PATEN with a foot. Weight 6.3 oz. Diam. $5\frac{1}{2}$ in. Diam. of the foot $1\frac{3}{8}$ in. Height $1\frac{1}{4}$ in. Date 1747.

Maker's mark only as on cup repeated three times.

This paten has a flat edge $\frac{1}{2}$ an inch wide, the middle being sunk flat $\frac{1}{8}$ of an inch in depth. The foot is a disk attached to the paten by a thick stem swelling out to both ends. In the centre of the paten is the sacred monogram.

* *Ibid.* p. 376. † *Bridges Hist. of Northants.* Vol. i. p. 200. ‡ The General of the Pretender's army in 1715. § For pedigree of Foster, see that of "the Forsters and Fosters," by J. Foster, 1871. || *Life of Bishop Crewe*, in *The Dictionary of National Biography*. ¶ For summary of will and much of the above information, see *Nichols*, Vol. iv., p. 836.

SILVER FLAGON. Weight 19 oz. Height $11\frac{3}{4}$ in. Diam. at the top $2\frac{3}{4}$ in.; at the foot $3\frac{5}{8}$ in. Date 1871.

London hall marks.

This is a plain jug-shaped flagon. Its lid is surmounted with a double cross. On one side is the sacred monogram, below which is: "*The gift of Robert Green, to the church at Normanton, 1875.*"

PEWTER FLAGON. Height 10 in. Diam. at the top 4 in.; at the foot $5\frac{1}{4}$ in.

Marks. 1. On the drum and on the lid, a conventional flower within a lozenge, repeated four times. 2. On the bottom inside, a garb between two mullets surmounted by "**John A — ester,**" within a dotted circle.

This is a straight-sided flagon narrowing straight from the foot towards the top; with a flat lid.

PEWTER PATEN with a foot. Diam. $7\frac{1}{4}$ in. Diam. of foot $3\frac{5}{8}$ in. Height $2\frac{1}{2}$ in.

Marks. 1. X. 2. In four shaped shields: (a) Lion rampant. (b) Leopard's face. (c) Sun in splendour. (d) — F.

This is a flat paten with a gadrooned edge. Its foot is hollow, swelling out into a gadrooned edge.

Edward Green, the donor of the silver cup and paten to this church was a younger son of **Robert Green**, of this parish, by his wife, **Martha Moore**, of Shackerstone. His family were for many years settled in this parish as yeomen. Mr. **Green** died unmarried on 27th Sep., 1758, aged 60. A slate headstone stands to his memory in the churchyard of this parish on the South side of the church, on which is also an inscription to the memory of **Martha Green**, his sister. Mr. **Edward Green's** eldest brother, **Robert**, married **Mary Bakewell**, of Swepston. Their grandson **Valentine Green**, succeeded to the **Bakewell** property at Swepston, and bought in 1807 the lordship of Normanton-le-Heath from the **Fermor** family; but sold it again in 1826 to **William Strutt**, the grandfather of the present owner **Lord Belper**. Mr. **Valentine Green** married and left a numerous family: his eldest son is **Robert Green**, of Scalby, near Scarborough, the donor of the silver flagon to this church. Another son is the Rev. **J. H. Bakewell Green**, the rector of this parish, who was presented to this living at the time of its separation from Nailstone in 1852. These two brothers are therefore the great-great nephews of the donor of the cup and paten.

NORTON-BY-TWYCROSS.

SILVER CUP. Weight 6.7 oz. Height $6\frac{1}{2}$ in. Diam. of bowl $3\frac{3}{8}$ in.; of foot $3\frac{1}{4}$ in. Height of stem $3\frac{1}{4}$ in. Date 1781.

Hall marks. 1. Small Roman F in a square shield. 2. Leopard's head crowned in a rounded shield. 3. Lion passant in a plain oblong. 4. T. W., a pellet between the letters within a plain oblong.

This cup has a bowl somewhat egg-shaped, a narrow stem swelling in the middle into a narrow band for a knob, and a plain foot ending in a round moulding and a flat edge.

SILVER PLATED PATEN. Diam. $5\frac{5}{8}$ in.

This paten has a flat edge, and is sunk in the middle so as to fit on to the cup.

SILVER PLATED FLAGON. Height 12 in. Diam. at the top $2\frac{1}{4}$ in.; at the foot $4\frac{1}{2}$ in.

This is a plain tall jug-shaped flagon.

PEWTER PLATE. Diam. $9\frac{3}{8}$ in.

On the edge is N. P. for Norton parish.

This is a plain plate with no other marks on it.

The silver plated flagon was given in 1872 by Mr. **John Savidge**, of Gopsal farm.

ORTON-ON-THE-HILL.

SILVER CUP. Weight 10.3 oz. Height $8\frac{1}{4}$ in. Diam. of the bowl $3\frac{5}{8}$ in.; of the foot $3\frac{3}{8}$ in. Height of stem $4\frac{1}{2}$ in. Date 1622. (PLATE 32.)

Hall marks. 1. Italic E in a plain shield. 2. Leopard's head crowned. 3. Lion passant; each of the latter being within an outer line of the shape of the stamp. 4. H. S., an indistinct object below, within a shaped shield.

This is a pretty little cup with a bell-shaped bowl, gilt inside, and a tall thin baluster stem rising out of a flat sloping foot. The inside of the foot underneath is filled with a piece of wood.

SILVER PATEN with a foot. Weight 5.2 oz. Diam. $5\frac{7}{8}$ in.; of the foot $2\frac{1}{2}$ in. Height of the foot $1\frac{1}{2}$ in. Date 1717.

Hall marks. 1. Capital Roman B in a plain shield. 2. Britannia. 3. Lion's head erased. 4. Capital old English I and small old English A, a pellet above the A, within a shaped shield; the mark of *Henry Jay*.

This paten has a flat edge, its middle part being sunk flat. Its foot is a hollow drum ending in a round moulding and a flat edge. Round the edge is: "*D. D. S. Steele, Arm: 1717.*"

SILVER PLATED FLAGON. Height $11\frac{1}{4}$ in. Diam. at the top $3\frac{3}{8}$ in.; at the foot $5\frac{1}{4}$ in.

This is a plain straight-sided flagon narrowing to the top.

TWO SILVER PLATED DISHES. Diam. of each $8\frac{3}{4}$ in.

The lord of the manor of Orton and one of the principal landowners in this parish in 1622 was **Robert Bradshaw**.

The donor of the silver paten to this church was **Samuel Steele**, Esq., lord of the manor and owner of most of the land of this parish. His grandfather, **John Steele**, bought in about 1640, Morebarn Grange from the **Bradshaws**, and in the reign of **Charles II.**, the manor of Orton. Mr. **S. Steele**, who was the third son of **John Steele**, by **Theodosia**, the daughter of **Richard Beardsley**, of Amington, Warwickshire, was born on 6th March, 1677. Both his elder brothers having died without issue, he succeeded to the estates in this parish in 1710. He himself died unmarried on 17th April, 1731; his property subsequently passing to the son of his sister **Sarah**, the

wife of the Rev. **John Perkins**, vicar of Orton, and rector of Kisingbury, Northants, a member of an ancient Warwickshire family; whose direct descendant is the principal proprietor in Orton at the present time.

A marble tablet surmounted by an angel blowing a trumpet, was placed in this church to the memory of **Samuel Steele**, by his sister, Mrs. **Perkins**. This is now upon the North wall of the side chapel leading out of the North aisle.*

Mr. **Steele** bore these arms: *Argent a lion rampant Azure between three gads of steel proper.*

On 30th Oct., 1739, administrations were granted at Leicester of the goods of four members of the **Steele** family to their nephew on "the mother's side," **John Perkins**; these four brothers and sisters being, **John Steele**, "late of Orton, gent.," **Samuel Steele**, **Barbara Steele**, "late of Orton, spinster," and **Mary Steele**, "late of Orton, spinster."

SHACKERSTONE.

SILVER CUP. Weight 4.9 oz. Height $6\frac{3}{4}$ in. Diam. of the bowl $3\frac{3}{4}$ in.; of the foot $2\frac{7}{8}$ in. Height of stem $2\frac{1}{2}$ in. Date 1727.

Hall marks. 1. Capital Roman M in a plain shield. 2. Leopard's head crowned in a plain shield. 3. Lion passant in a plain oblong. 4. M, a mullet above and below.

This cup has a bowl shaped into an inverted truncated cone with concave sides, a thick round stem with a round moulding between two small hollows for a knob, and a plain foot, ending in a round moulding, and flat edge. On the bowl in script letters is "J. M. B., G. T. 1727;" the J. M. being in monogram: these are the initials of the churchwardens for that year, **Michael Bound** and **George Taylor**.†

SILVER COVER PATEN with a foot. Weight 2.6 oz. Diam. $4\frac{1}{2}$ in. Diam. of foot $1\frac{3}{8}$ in. Height of foot $\frac{3}{8}$ in. Date 1610.

No marks.

This paten has a flat edge round which is a rim. It is sunk in a rounded shape, and has round its top a band $\frac{1}{2}$ an inch wide divided into four parts by hour-glass curves. The straps of this band have a zigzag line upon them, and enclose five rows of little horizontal strokes. The foot is a disk attached to the paten by a thick short stem. Round the edge of the foot is: "*Shakerston, W. S., T. R.:*" and across the middle is the date "1610." The initials stand for **William Sarson** and **Thomas Roe**; churchwardens.‡ This paten was plainly the cover to a cup made in 1610; which was replaced by the present one in 1727, so made as to allow the old cover to fit on to the new cup.

SILVER DISH with a foot. Weight 28.8 oz. Diam. $10\frac{3}{4}$ in. Diam. of foot $4\frac{3}{4}$ in. Height of foot $2\frac{7}{8}$ in. Date 1748.

Hall marks. 1. Small Roman N in a shaped shield. 2. Leopard's head crowned in a shaped shield. 3. Lion passant in a shaped oblong. 4. I. W. in script letters in a plain oblong; mark of *John Wirgman*.

This is a wide flat dish with a small round raised edge. Round the middle is: "*The gift of Ann, the wife of William Gibbs, to Shakerston church, 1749.*"

* For pedigrees of Steele and Perkins, see *Nichols*, Vol. iv., pp. 853 and 854.* + Ex. inform., G. H. & T. Nevinson. The J was probably engraved by mistake. † *Vide* Parish register in *Transac. of Leic. Archite. Soc.*, Vol. v., p. 262.

PEWTER PLATE. Diam. 9 $\frac{3}{8}$ in.

Marks. On the edge: C. W. A. Underneath: 1. X crowned. 2. A. M. 3. Three indistinct shapes.

PEWTER PLATE. Diam. 8 $\frac{3}{4}$ in.

Marks. On the edge: M. F. repeated twice. Underneath: 1. Rose crowned between two leaves, within a dotted oval. 2. St. Catherine's Wheel, an illegible name above, "Bridge" below. 3. "London" on a scroll.

The silver dish was bought in accordance with this clause in the donor's will made 20th March, 1743-4, and proved in Leicester on 10th Oct., 1751: "*I give £10 to buy a silver salver to be given to Shackerstone church.*" Mrs. **Ann Gibbs** was twice married, first to **William Glenn**, of Bilston, in Norton, who died on 7th Sep., 1734, aged 73, and was buried at Norton.

William Glenn, "of Bilson in Norton," in his will made 31st Oct., 1730, and proved in Leicester on 26th Dec., 1734, charged his estates with the annual payment of £16, as follows: £5 to the poor of Bilston and Norton each, £2 10s. od. to the poor of Congerstone and Shackerstone each, and £1 for a sermon preached on the day of his death by the ministers of Norton, Congerstone, and Shackerstone alternately, they to distribute his bequests to their poor with the help of one or two neighbours; he left to "cousin" **Clayton** £20, and to her son **William Clayton** £20, and to her three sisters £20 each; "cousin" **William Hodges** £15; "cousin" **Dorothy Pratt** £15; "cousin" **Martha Hudson** £20; all lands and houses to wife **Anne** for life, and after her death to kinsman **Robert Glenn**, of Sibson; wife residuary legatee and sole executrix.

His widow married secondly in 1738, the Rev. **William Gibbs**,* who was appointed to this living in 1732, and to the rectory of Congerstone in 1740, when he took up his residence in the latter parish. Mrs. **Gibbs** died leaving no issue by either husband on 6th April, 1744, aged 57, and was buried in the sanctuary of Congerstone church. Her husband married secondly on 12th Nov., 1745, at Ibstock, **Ann Heatley**, widow, which lady was baptized at Ibstock, on 6th May, 1712, being the daughter of **Harrington** and **Ann Power**, and was buried there on 1st Oct., 1773.† Mr. **Gibbs** held both livings until 28th March, 1757, when he resigned Shackerstone owing to ill health; he died on 10th July, 1757, aged 57, and was buried by the side of his first wife. The slabs to their memory are now in the pathway of the chancel.

Mrs. **Gibbs** left to the poor of each of her husband's parishes and to the poor of Bilston, 50s. each. She appointed her husband sole executor, and left him her land at Donisthorpe after the death of her sister, **Sarah Hudson**, who was to have it for life;‡ he upon coming into it to pay legacies to the said sister's children **Ann**, **Susanna**, **Mary**, and **Frances**.

It will be noticed that the date on the dish is not that of the donor's death, but the year in which her bequest was carried out. If it had not been for the clause in her will, her successor would probably have received the credit of having made this gift.

* Marriage bond dated 27th Jan. *Transac. of the Leic. Architect. Soc.*, Vol. vii. † Ibstock Parish Register.

‡ "Sarah wife of Thomas Hudson, buried 30th July, 1756." Netherseale parish register.

SHEEPY.

SILVER CUP. Weight 6.7 oz. Height 6 in. Diam. of bowl $3\frac{1}{4}$ in.; of foot $3\frac{1}{4}$ in. Height of stem $2\frac{5}{8}$ in. Date *circa* 1575. (PLATE 30.)

Mark. A rose.

This cup is in good condition and has, like others of this series, a bowl with wide lip and projecting base, a stem, with a small knob, swelling out only a little to each end, and a wide foot. Round the bowl is a band of stroke ornament divided into six parts by hour-glass curves.

SILVER CUP. Weight 9.4 oz. Height $8\frac{3}{8}$ in. Diam. of bowl and of foot $3\frac{5}{8}$ in. Height of stem $4\frac{3}{8}$ in. Date 1722. (PLATE 30.)

Hall marks. 1. Capital Roman G in a plain shield. 2. Britannia. 3. Lion's head erased. 4. R inside G within a plain shield. Mark of *Richard Greene*.

This cup has a straight-sided bowl with a raised lip, a tall straight stem with a small round between two hollow mouldings for a knob, and a plain foot rounded off at the edge. On the bowl is the crest of the donor, *Within a chaplet Vert an escalop shell Or, Levinge*; below is "T. L. 1722."

SILVER PATEN with a foot. Weight 4.1 oz. Diam. $4\frac{1}{2}$ in. Diam. of foot $1\frac{7}{8}$ in. Height of foot $1\frac{1}{8}$ in. Date 1722.

Hall marks as on the last cup.

This is a flat paten with a raised edge; its foot being a disk attached to the paten by a stem swelling out at both ends. In the centre is the same crest and inscription as that on the cup.

SILVER DISH with a foot. Weight 9.5 oz. Diam. $7\frac{1}{4}$ in. Diam. of the foot $3\frac{1}{8}$ in. Height of foot $1\frac{7}{8}$ in. Date 1722.

Hall marks as on last cup.

This is a flat dish with a raised edge, having in its centre the same crest and inscription. Its foot is a hollow drum swelling out into a round moulding and a flat edge, underneath which is the lion's head erased.

SILVER DISH with a foot. Weight 9.3 oz.

Like the last.

SILVER FLAGON. Weight 25.7 oz. Height 10 in. Diam. at the top $3\frac{3}{8}$ in.; at the foot $5\frac{7}{8}$ in. Date 1722.

Hall marks as on the last cup.

This is a straight-sided flagon narrowing towards the top, with a flat top to its lid which has a round moulding running round its edge. In front is the same crest and inscription.

The more modern portion of this service of communion plate, was given by **Thomas Levinge**, Esq., the only surviving son of **Thomas Levinge**, by **Letitia**, daughter of **William Grosvenor** of Bridgenorth. The donor's grandfather, **Thomas**, who sprang from the **Levinges** of Baddesley Ensor, Warwickshire, bought property in this parish from **Walter Astley** in 1637; which the donor was the last of his name to own, for he died on 24th Feb., 1731-2, at the age of 78, leaving a daughter only to succeed him, **Letitia**, who married on 12th Dec., 1717, at Sheepy, **Robert Holden**,* of Erdington, co. Warwick.

* Parish Register.

Mr. **Thomas Levinge's** wife **Katherine**, died on 18th Nov., 1715, at the age of 63. There was formerly in this church a blue slate in the floor containing a short inscription to the memory of both: this was removed at the time the church was restored some years ago, and is now supposed to be under the pavement.

The arms of **Levinge** are, "*Vert, a chevron Or, in chief three escalop shells Argent.*"*

RATCLIFFE CULEY.

SILVER CUP. Weight 6.5 oz. Height $7\frac{3}{8}$ in. Diam. of the bowl $3\frac{1}{2}$ in.; of the foot $3\frac{1}{4}$ in. Height of stem $3\frac{3}{4}$ in. Date 1742.

Hall marks. 1. Small Roman G in a shaped shield. 2. Leopard's head crowned in a shaped shield. 3. Lion passant in a shaped oblong. 4. W. V., two pellets between the letters and a rose above.

This cup has a straight-sided bowl with a raised lip, a thick straight stem with a small round on a fillet for a knob and a plain foot with mouldings running round its edge.

SILVER PLATED PATEN. Diam. $5\frac{5}{8}$ in.

This is a flat paten sunk in the middle. On the edge is the sacred monogram within a circle and a cross within a circle, each device being repeated twice.

TWO PEWTER PATENS with feet. Diam. of each $7\frac{1}{8}$ in. Diam. of the foot $3\frac{1}{2}$ in. Height of foot $2\frac{1}{4}$ in.

Marks. 1. X crowned. 2. Lion passant in a shaped oblong. 3. Leopard's head within a circle. 4. Seeded rose. 5. R. M. in a shaped oblong. 6. Lion passant, a crown and "**Robert**" above. 7. "**Robt. More**" in an oblong.

These patens are flat with raised edges; they stand upon thick round stems narrowing in the middle.

PEWTER FLAGON. Height $7\frac{1}{4}$ in. Diam. at the top 4 in.; of the foot $4\frac{3}{8}$ in.

Marks. 1. Sun in splendour. 2. X. 3. "B & V," in a shaped oblong. On the bottom is an X crowned with "B & V" in a shaped oblong below.

This is a tankard with bulging sides, a round top to its lid and an R-shaped handle.

The silver cup was bought during the incumbency of **Silvester Vincent**, rector of Sheepy and Ratcliffe from 1741 to 1758. Mr. **Vincent's** family and the **Farmer** family were at that time the principal landowners in this parish.

SIBSTONE.

SILVER CUP WITH COVER PATEN. Weight of cup 6.9 oz. Height $6\frac{1}{2}$ in. Diam. of the bowl and of the foot $3\frac{3}{8}$ in. Height of stem $2\frac{1}{2}$ in. Date 1573. (PLATE 30.)

Hall marks. 1. Small black-letter Q in a plain shield. 2. Leopard's head crowned. 3. Lion passant; both within an outer line. 4. S. H. in monogram within a shaped shield.

* For Pedigree see *Nichols*, Vol. iv., p. 952.

This cup has a deep bowl, shaped into an inverted truncated cone a little concave, which has round it a band of foliage divided into three parts by hour-glass curves. Its stem is evenly balanced, being divided in half by a fillet, upon which has formerly been a round moulding, now missing. From the middle the stem swells out considerably towards both ends, at each of which is a vertical edge. The foot is rounded off into a flat edge, upon which is the egg and tongue ornament.

SILVER COVER PATEN with a foot. Weight 2.5 oz. Diam. $3\frac{5}{8}$ in. Diam. of the foot $1\frac{1}{4}$ in. Height of foot $\frac{3}{4}$ in. Date 1573. (PLATE 30.)

Hall marks as on the cup.

This paten is of the usual shape, with a band of stroke ornament round the top, and round its edge a band of foliage similar to that round the cup, but narrower. The foot is a disk attached to the paten by a stem swelling out to both ends. Round the edge of the foot is a strap ornament, with a zigzag line, and across the middle the date "1573." The engraving on this pretty cup and cover is all very clear and sharp.

SILVER DISH. Weight 15.8 oz. Diam. 9 in. Date 1832.

Birmingham hall marks.

This is a plain and solid dish, having in its centre the sacred monogram with a cross and three nails within a circle of glory, round which is; "*The Bequest of the late Mary Grew, widow, to the parish church of Sibstone. Anno Domini, 1832.*"

SILVER PLATED FLAGON. Height $10\frac{1}{2}$ in. Diam. at the top $1\frac{5}{8}$ in.; at the foot $3\frac{1}{2}$ in.

This is a plain modern jug-shaped flagon.

PEWTER PLATE. Diam. $9\frac{3}{8}$ in.

Marks. On the edge. 1. Capital Roman H in a shaped shield. 2. Capital Roman S in a shaped shield. 3. A conventional flower in a shaped stamp repeated four times. On the back of the plate is a bell between R. A., within a dotted circle.

This plate has a wide flat edge, and is sunk flat in the middle $\frac{1}{2}$ an inch in depth. On the edge is this coat of arms in a lozenge, surrounded by conventional foliage; *A chevron between three saltires.*

PEWTER PLATE. Diam. 9 in.

Marks. 1. X crowned. 2. Rising out of a ducal crown, a horse's jamb. 3. "London." 4. I. D. 5. Eagle's head erased.

Mary Grew, the donor of the silver dish, was the daughter of **William Dickinson**, farmer of Twycross, by **Mary**, his wife, and was baptized at Twycross, on 17th April, 1763.* She was married on 9th July, 1785, at Sibstone, to Mr. **Benjamin Grew**, of this parish, a member of a family settled here as farmers for many years; he was the son of **John** and **Hannah Grew**, and was baptized here on 7th Sep., 1760. **Mary Grew**, was early left a widow, since her husband died on 9th Sep., 1789, and was buried here on the 13th. Two daughters only were born to them, **Mary**, baptized here on 6th Oct., 1786, and **Elizabeth**, baptized on 16th Jan., 1788. Mrs. **Grew**, who lived during her widowhood at Appleby, survived her husband until the 22nd July, 1830, being buried at Sibstone, on the 27th.†

* Parish Register.

† Parish Register.

The two daughters placed in the nave of this church a marble tablet to the memory of their parents, **Benjamin** and **Mary Grew**, which is inscribed with their names and dates of death, and the words, "*Blessed are the dead which die in the Lord.*"

Mrs. **Grew**, died intestate, so that her bequest must have been carried out in accordance with some verbal instruction given at the time of her death. Letters of administration were granted on 27th Dec., 1830, P.C.C. to her daughters, **Mary** and **Elizabeth**; and a second administration of goods not before administered, was granted as late as July, 1863.

TWYXCROSS.

SILVER CUP. Weight 17.4 oz. Height $9\frac{1}{4}$ in. Diam. of the bowl $4\frac{3}{8}$ in.; of the foot $3\frac{7}{8}$ in. Height of stem $4\frac{3}{4}$ in. Date 1717.

Hall marks. 1. Capital Roman B in a plain shield. 2. Britannia. 3. Lion's head erased. 4. Capital Roman R inside G, in a plain shield with a flaw in the top. The mark of *Richard Greene*.

This cup has a straight-sided bowl with a raised lip and a flat base. Its stem is straight and thick, divided in half by a round between two hollow mouldings for a knob. The foot has mouldings running round its edge.

SILVER CUP. Weight 17.1 oz. Date 1717.

Hall marks as on first cup.

This is the same in shape as the first with the exception of its being very slightly higher.

SILVER COVER PATEN with a foot. Weight 7.9 oz. Diam. $5\frac{1}{2}$ in. Diam. of the foot $2\frac{1}{4}$ in. Height of foot $1\frac{1}{4}$ in. Date 1717.

Hall marks as on the cups.

This paten has a narrow flat edge, the middle part being sunk flat. The foot is a disk attached to the paten by a thick stem swelling out at both ends.

SILVER COVER PATEN with a foot. Weight 7.7 oz. Date 1717.

The same as the last.

SILVER PLATED DISH. Diam. 8 in.

In 1717 **Charles Jennens**, Esq., was lord of the manor of Gopsal, Twycross and Norton. It was most probably owing to his bounty that Twycross came into possession of this silver communion service. This gentleman was the eldest son of **Humphrey Jennens**, of Erdington Hall, Birmingham, a great ironmaster, and the purchaser of these manors from Sir **John Lowther**, by **Mary**, daughter of Col. **Milward**, of Snitterton, and was born in 1662; **Charles Jennens** inherited Gopsal on the death of his father in 1690, and was the first of his family who resided in the old house there. He died on 4th July, 1747, and was buried at Nether Witacre, co. Warwick, where was a property which had also been bought by his father.

Mr. **Charles Jennens**, married on 11th Dec., 1689, **Elizabeth**, daughter of Sir **Robert Burdett**, of Formark, and by that lady, who died in 1708, had a son **Charles**, his successor, and with other children, a daughter, **Elizabeth**, who married in 1737 her first cousin **William Hanmer**, of Hanmer, co. Flint, whose daughter **Esther**, married in 1756,

Assheton Curzon, Viscount Curzon, great-grandfather of Earl Howe, the present owner of Gopsal.*

GOPSAL.

In the private chapel of Gopsal, the seat of the Right Hon. Earl Howe, is a

SILVER GILT CUP. Weight 33.6 oz. Height 10½ in. Diam. of the bowl 4¼ in.; of the foot 7½ in. Height of the stem 6½ in. Date 1692. (FIG. 47.)

Marks on the edge of the foot. 1. A small pine-apple ¼ of an in. long; the Augsburg assay mark. 2. I. L. in a plain oblong; the maker's mark.

This very beautiful German made cup has a bowl somewhat bell-shaped, and a baluster stem swelling out into a wide foot; with the exception of the plain portion round the lip, the whole piece is covered with foliage repoussé and chaste, studded all over with a many different precious stones. Three cherubs' heads project from the stem. On the bowl are three oval enamels in delicate colours set in a jewelled border; their subjects being, the Annunciation; Visit of the Virgin to Elizabeth, and the Nativity. Three similar enamels are placed on the foot, of which the subjects are; the Circumcision; Visit of the Wise Men; Christ in the midst of the doctors.



Fig. 47. 1692. ½ of full size.

* For pedigree of Jennens, see *Nichols*, Vol. iv., p. 859; and of Curzon, *Leicestershire Pedigrees* by W. G. D. Fletcher, p. 94.

Under the foot is rather rudely engraved this coat of arms: *Quarterly*. 1. *Or, a dexter arm embowed vested Gules the hand holding a stone proper*; Abbey of St. Stephen, Würzburg. 2. *Or, a cockatrice Gules*; Abbey of Banz. 3. *Argent, a gate embattled Gules*; Town of Kissingen. 4. *A bunch of grapes in bend*; **Weiner**. Above are the initials "E. A. S. S.," for "**Eucharius, Abbas Sancti Stephani**," and below, the date "1692;" (FIG. 48.) the shield is ensigned with a mitre between two pastoral staffs representing the two Abbeys.



Fig. 48.

It fits on to the chalice, and to all appearance has always belonged to it.

From a communication kindly sent by Mr. **Gustavus A. Seyler**,* I am able to say that the coat of arms shows that this cup formerly belonged to the Abbey of St. Stephen, Würzburg, to which it was given by the Abbot **Eucharius**, in 1692. This Abbot's name was **Eucharius Weiner**: he was a native of Kissingen, and so quartered the arms of that town; the bunch of grapes in the fourth quarter doubtless represents his own "canting" arms. He was elected Abbot of St. Stephen, Würzburg, on 23rd June, 1667, and assumed also the position of Abbot of Banz. He died at St. Stephen's, on 11th April, 1701. The Abbot **Eucharius**, in "*Episcopatus Wirceburgensis*," (page 278), by **Ussermann**, is mentioned as having presented to the church of St. Stephen many valuable utensils. Both Abbeys were secularized early in the present century.

The cup and paten were purchased for the use of his private chapel, by **Richard William Penn Curzon Howe**, 1st Earl **Howe**, kindly memories for whom will long live in the hearts of Leicestershire people.

WITHERLEY.

SILVER CUP. Weight 5.3 oz. Height 5 $\frac{5}{8}$ in. Diam. of the bowl 3 $\frac{1}{8}$ in.; of the foot 3 $\frac{1}{8}$ in. Height of stem 2 $\frac{5}{8}$ in. Date *circa* 1575. (PLATE 30.)

Mark. A rose.

This little cup is in all points a regular example of the "rose" series, and is almost the counterpart of the one at Sheepy figured on the same plate. Round its bowl is a band of stroke ornament, divided into six parts by hour-glass curves. Reeds run round both ends of the stem, and the edge of the foot.

SILVER PATEN. Weight 8.8 oz. Diam. 8 $\frac{1}{2}$ in. Date 1804.
London hall marks.

* Librarian and Lecturer to the Royal Prussian Board of Trade, Berlin.

This is a plain dish with a raised boss in the centre, on which is; "*The gift of the Rev^d. Isaac Whyley, Rector, 1805.*"

PEWTER FLAGON. Height $12\frac{3}{8}$ in. Diam. at the top $4\frac{3}{8}$ in.; at the foot $6\frac{3}{8}$ in. Date *circa* 1688. (PLATE 32.)

Marks. 1. A conventional flower, possibly meant for a pomegranate, within a lozenge, repeated four times, both on the lid and on the drum. 2. Inside, on the bottom, a garb between two stars, round which is an illegible name, ending in *ESUR*.

This is a conical-shaped flagon rising straight up from the foot. Its lid has a flat top with a wide edge projecting over the drum. It has a plain round handle and a large purchase. Some years ago this flagon was plated. On the top of the lid is "1688, R. F., T. G., *Chur. War.*" "R. F.," stands for **Richard Farmer**.

PEWTER PLATE. Diam. $9\frac{5}{8}$ in. Date 1686.

Marks. 1. L. D., a pellet above and below, within a plain shield. 2. Three fleur-de-lis in a shaped shield. 3. Possibly a bird perched on a nest, in a shaped shield.

This is a plain plate with a flat edge, the middle part being sunk flat. In the centre is "*R. Farmer and R. Kiss, Churchwardens, 1686.*" Both the surnames are in monogram: the date is within a circle. The families of **Farmer** and **Kiss** were of importance in Witherley at this time, both being owners of land.

PEWTER DISH. Diam. 12 in. Depth $1\frac{1}{2}$ in.

Marks. 1. "Made in London." 2. Golden fleece within an oval, "**Samuel**" above, "**Ellis**" below. 3. Rose crowned, "**S. Ellis**" possibly above, "London" below.

The Rev. **Isaac Whyley**, the donor of the paten, a native of Warwickshire, was admitted as a sizar to Emmanuel Coll., Camb., on 11th June, 1748, and took his B.A. from thence in 1752.* He was ordained priest by the Bishop of Lincoln, in Conduit Street chapel, Hanover Square, on 23rd Dec., 1753, and instituted to the rectory of Witherley, on the presentation of **Theophilus Grove**, citizen, on 26th June, 1756;† remaining here till his death, on 16th April, 1805, aged 75.

Mr. **Whyley**, was twice married; his first wife, **Catherine**, died on 18th Nov., 1768: by his second wife, **Priscilla Howes**, widow, who died on 26th March, 1821, aged 81, he had with other children, a son, **Isaac**, of Ch. Coll., Camb., who died 19th Aug., 1802, aged 26, and a daughter, **Charlotte Priscilla**, who died 1st Oct., 1817, aged 38.

To the memory of Mr. **Whyley**, and the above members of his family, there is a mural monument in this church on the South side of the chancel, surmounted by these arms; *Ermine, on a chevron Gules three escalops Or; impaling; Or three piles Sable, on a canton Argent a star of six points of the second.*

In his will, made 26th March, 1803, and proved P.C.C. on 3rd Sep., 1805, the Rev. **Isaac Whyley**, left all his real and personal property between his wife, **Priscilla**, and daughter, **Charlotte Priscilla**, equally; if the latter dies without a will, such property to pass after her death to "son" **Gregory Whyley**, and "daughter" **Charlotte**, wife of **Andrew Meers**.

* College Register.

† Bishop's Registers.

SPARKENHOE SECOND DEANERY.

ASTON FLAMVILLE.
 BURBAGE.
 BARWELL.
 STAPLETON.
 POTTERS MARSTON.
 CADEBY.
 CARLTON.
 EARLS SHILTON.

ELMSTHORPE.
 HIGHAM-ON-THE-
 HILL.
 HINCKLEY.
 TRINITY CHURCH.
 KIRKBY MALLORY.
 MARKET
 BOSWORTH.
 BARLESTONE.

SHENTON.
 SUTTON CHENEY.
 MARKFIELD.
 PECKLETON.
 STOKE GOLDING.
 DADLINGTON.
 THORNTON.
 BAGWORTH.

ASTON FLAMVILLE.

SILVER CUP. Weight 7.2 oz. Height $5\frac{3}{4}$ in. Diam. of the bowl $3\frac{3}{8}$ in.; of the foot $3\frac{1}{2}$ in. Height of the stem $2\frac{3}{4}$ in. Date 1636. (PLATE 31.)

Hall marks. 1. Italic T in a plain pointed shield. 2. Lion passant. 3. Leopard's head crowned; each of the two last having an outer line following its outline. 4. P. S., a pellet between the letters, a heart and four pellets below, within a shaped shield.

This cup has a nearly straight-sided bowl and an evenly-balanced stem, divided in half by a round moulding on a fillet for a knob. The foot is rounded off into a flat edge, under which the lion passant is repeated.

SILVER PATEN. Weight 2.4 oz. Diam. $4\frac{1}{2}$ in. Date 1636. (PLATE 31.)
 One mark only, the maker's, as on the cup.

This flat paten, sunk slightly in the middle, fits on to the cup as a paten only and not a cover; it is however different to others of this date in being entirely without a foot.

PEWTER PLATE. Diam. $9\frac{1}{2}$ in.

Marks. 1. A. W. S. 2. "Aston." 3. "London." 4. An eagle displayed, "Thomas" above, "Hodgkin" below.

The sole landowners in this parish in 1636, were **George Turville** who died in 1649 and his son **Henry**, who died in 1671.*

This ancient family came into this estate in about the year 1400, through the marriage of **Richard Turville** of Normanton Turville, with the only daughter of **William de Flamville**, and retained it for more than 300 years. The present representative and direct descendant of **Richard Turville**, is **Sir Francis Fortescue Turville**, K.C.M.G., of **Husbands Bosworth Hall**.

* See *Nichols*, Vol. ii., p. 465. and Vol. iv., pp. 447. & 1004.

BURBAGE.

(a)

SILVER CUP. Weight 13 oz. Height $8\frac{1}{2}$ in. Diam. of the bowl $4\frac{1}{2}$ in.; of the foot $3\frac{5}{8}$ in. Height of stem $2\frac{1}{4}$ in. Date 1783.

Hall marks. 1. Small Roman H in a square shield. 2. Leopard's head crowned in an oval shield. 3. Lion passant in a plain oblong. 4. G. S. in an oblong.

This cup has a plain deep egg-shaped bowl, with a thin tall handle on either side, rising above the lip. The bowl rests on a short narrow stem, swelling out into a plain round flat foot. A beaded moulding runs round the edge of the foot and also round both edges of the handles at the top. Underneath the foot is; "*Donum Richardi Spooner Jacques. Anno 1784.*"

(b)

SILVER CUP. Weight 26.3 oz. Height $10\frac{5}{8}$ in. Diam. of the bowl $5\frac{1}{2}$ in.; of the foot $5\frac{3}{8}$ in. Height of the stem 5 in. Date 1787.

Hall marks. 1. Small Roman M in a square shield. 2, 3, and 4, as on the first cup.

This is a huge cup with a straight-sided bowl narrowing towards the lower part, where it is rounded off. It has a plain stem, 1 inch thick in the middle, swelling out into the bowl and into a plain foot. On the bowl is; "*Fons Salutis,*" and under the foot; "*Hæc Lagena emptæ erat anno 1787, a Richardo Spooner Jacques et Johanne Miller.*"*

SILVER PLATED PATEN. Diam. $8\frac{1}{8}$ in.

This is a copper-plated paten in the shape of a salver, with a raised beaded edge. Underneath are three feet. On its edge is; "*Vcho Panem Vitæ.*"†

SILVER PLATED DISH. Diam. $8\frac{1}{4}$ in.

This is a plain dish plated on copper. Round its edge is; "*Colligo Eleemosynas. Caritas operiit multitudinem peccatorum.*"‡

TWO SILVER ELECTRO-PLATED PATENS. Diam. of each $5\frac{1}{4}$ in.

Underneath each is; "*Given by the Burbage Sunday School Teachers, Nov. 6th, 1879.*"

SILVER ELECTRO-PLATED FLAGON. Height 11 in. Diam. at the top $2\frac{3}{8}$ in.; at the foot $3\frac{1}{2}$ in.

This is a modern jug-shaped flagon of the usual shape, having a cross on its lid.

From Archdeacon Bickham's inventory, repeated in *Nichols*, (Vol. iv. p. 463,) we learn that the following communion plate belonged to this parish in 1778.

	oz.	dwt.
"One chalice or flagon, weight.....	64	1
with this inscription; ' <i>Ex dono Roberti Cotes, M.A., hujusque ecclesie rectoris, 1717,</i> ' and a coat of arms with this motto; ' <i>In celo spes mea est.</i> '		
One plate with the same arms and inscription	19	15
One salver, ' <i>The gift of Grace Armston to the church of Burbage,</i> ' weight ...	15	16
One cup with no inscription, weight.....	8	4"

In the night of 8th Feb., 1784, all four pieces of that service were

* "This vessel was bought in the year 1787 by Richard Spooner Jacques and John Miller." † "I carry the Bread of Life." ‡ "I gather alms. Charity covers the multitude of sins."

stolen out of the church. A reward of 20 guineas was offered by the churchwardens for the apprehension of the thieves, but in vain.

The oldest piece of stolen plate was most likely the cup.

The stolen salver was provided in accordance with this clause in **Grace Armston's** will, made 19th April, 1686, and proved P.C.C. 2nd Dec., 1691; "*And £5 I desire may be laid out on a piece of plate, and be given to the church of Burbage, to be for ever used there in the administering of the holy sacrament.*" **Grace Armston**, was one of the daughters of **James Armston**, a landowner of Burbage, by his wife, **Anne**, daughter and co-heir of **George Wale**, of Walcot, and died unmarried: she was buried in this church on 13th Oct., 1691.* She was the sister of **Lady Noel**, the donor of a piece of plate to Scraftoft church.†

In her will, **Grace Armston** left to her brother and executor, **James Armston**, her lands in Stapleton, co. Leicester, and elsewhere, charged with the payment of these legacies; £5 to "aunt **Kington**;" £3 each to poor of Stapleton and Burbage; £100 to "sister **Lady Noel**;" £21 to **Sir Andrew Noel** for a gold watch; £100 to "nephew" **Sir Edward Wigley**, and £100 to him on his wedding day; £100 to "nephew" **Andrew Noel**; plate and linen to her mother.

Robert Cotes, the donor of the lost flagon and plate, was the only son of **Robert Cotes**, of Leicester, by **Margaret**, daughter of **Henry Astley**, of the same town, and was baptized on 9th Sep., 1649. He took his B.A. degree from Emman. Coll. Camb., in 1670, and M.A., in 1674. He was rector of Aston and Burbage from 1677 till his death, on 8th Nov., 1717. By his first wife, **Grace**, the daughter of **John Farmer**, of Barwell, buried here on 25th June, 1686. Mr. **Cotes** was the father of **Roger Cotes**, the first Plumian professor of Astronomy, who died 5th June, 1716. There was formerly a slab over Mr. **Cotes'** grave in the chancel of Burbage church, bearing a Latin inscription:‡ this has gone the way of his gift of plate. This gift is accounted for by the following clause in the donor's will, made 24th Sep., and proved at Leicester on 12th Dec., 1717. "*I give and bequeath to the church of Burbage aforesaid the sum of £30, to be laid out in buying of a silver flagon and silver bason, viz., the flagon for the wine, and the bason for gathering the offerings at the Communion in the said church, and there to remain for those uses for ever.*"

To his second wife **Mary**, who was buried here on 23rd May, 1719, Mr. **Cotes** left for her life, with other property, the house in Burbage in which he lived, and also a house occupied by widow **Carr**; these two houses with their buildings etc., after his wife's death he bequeathed to the rector of Aston and Burbage for the time being, on condition that the rector pays £5 a year towards apprenticing a boy of this parish or Sketchley, who has been well instructed in the church catechism. Mr. **Cotes** made various other charitable bequests;

* Parish Register. † Page 220. ‡ For which and pedigree, see *Nichols*, Vol. iv., pp. 465 and 35.

towards repairing Aston church tower £5; to the poor of Burbage and Sketchley £5; and £3 to each of the following parishes for their poor, Aston Flamville, Croft, Hinckley, Barwell, St. Martin's and St. Margaret's, Leicester. He left legacies to the following relatives; **Robert and Elizabeth**, the children of his late brother-in-law, the Rev. **John Smith**; **Richard Hood**, his nephew, rector of Heringham, Suffolk; **Elenor Weston**, his niece; and **Elizabeth Sumerfield**, his sister.

The arms of **Cotes** as given in the visitation for 1619 are; "*Argent, a fret Azure on a canton Or a lion rampant Sable.*" Crest: *A cock Or wattle Gules.*" On the seal however to Mr. **Cotes'** will, the canton is charged with a mullet instead of the lion rampant, and his arms were probably thus engraved upon his gift of plate.

(a)

The donor of the two-handled cup was the posthumous son of **Richard Jacques**, of Sketchley in this parish, by his second wife, **Elizabeth**, daughter of — **Filter**, of Burbage, and was baptized at Hinckley, on 26th April, 1743. **Richard Spooner Jacques**, was high sheriff of the county in 1792: he was one of the principal landowners in Sketchley, and, "by frugality and care, he increased his patrimonial inheritance to a large amount."* Mr. **Jacques** died unmarried at Sketchley, on 30th Jan., 1811, and was buried in a vault in Wolvey church, co. Warwick.

In his will dated 3rd July, 1803, and proved 27th April, 1811, P.C.C., Mr. **Jacques** left £100 to the vicar and other officials of Hinckley, the interest to be spent as follows: 10s. 6d. to the vicar for preaching a sermon on Christmas day, the rest to be laid out in loaves for the poor of Hinckley; £100 to Burbage, the interest to be spent in a similar manner; this is now laid out in the purchase of gowns for ten widows, any balance in coals; £100 to the parish of Wolvey, the interest of which is now spent in bread for the poor every Christmas; £200 to the Leicester Infirmary.

(b)

The second cup was no doubt provided owing to the first one proving inconvenient to use on account of its handles rising above the lip, which do not however prevent its being used as a flagon. Whether this other one had been given by Messrs. **Jacques** and **Miller**, or whether they had bought it with the parish money, could not have been told from its vaguely worded inscription. This entry however made in 1787, in the churchwardens' accounts, which begin in 1757, shows it to have been the gift of the parishioners; "*Paid Mr. Mann a bill for Communion Plate, £19 6s. 4d.*" Messrs. **Jacques** and **Miller** were the churchwardens that year.

BARWELL.

SILVER CUP. Weight 10 oz. Height $8\frac{5}{8}$ in. Diam. of the bowl $3\frac{3}{8}$ in.; of the foot $3\frac{3}{8}$ in. Height of stem $4\frac{3}{8}$ in. Date 1847.

London hall marks.

* *Nichols, Add. and Cor.*, p. 147.

This cup has a straight-sided bowl rounded off below, on which is the sacred monogram within a circle of glory. The stem has a plain round knob in the middle. The foot is quite plain with "*Barwell Church, 1847,*" upon it.

SILVER PLATE. Weight 12.2 oz. Diam. 9 $\frac{3}{8}$ in. Date 1847.

This is a perfectly plain plate with the sacred monogram within a circle of glory in its centre. On its edge is: "*Barwell Church, 1847.*"

SILVER PLATE. Weight 12 oz.

Same as the last.

PEWTER PLATE. Diam. 9 $\frac{3}{8}$ in.

Marks. 1. Eagle displayed, "*Thomas*" above, "*Hodg—*" below. 2. "*London.*" 3. "*Barwell.*" 4. X crowned.

This silver service of communion plate, was given to Barwell church by Mrs. **Pearson**, the eldest daughter of the late Rev. **G. Mettam**, who was rector here from 1803 to 1853. This lady married General **Pearson**, of The Hassels Sandy Beds, and lord of the manor of Barwell, on 11th Nov., 1837. Mrs. **Pearson** is herself an owner of land in this parish.

STAPLETON.

SILVER CUP. Weight 8.1 oz. Height 8 $\frac{7}{8}$ in. Diam. of the bowl 3 $\frac{3}{8}$ in.; of the foot 3 $\frac{1}{4}$ in. Height of the stem 3 $\frac{3}{8}$ in. Date 1746.

Hall marks. 1. Small Roman L in a shaped shield, very indistinct. 2. Lion passant in an oblong shaped at the bottom. 3. Leopard's head crowned in a shaped shield. 4. T. W. in script letters within a shaped oblong; mark of *Thomas Whigham*.

This is a pretty little cup, with a straight-sided concave bowl rounded off at the lower end, and a baluster stem rising out of a foot ending in a round moulding and a flat edge. The bowl is beaten out of one piece of metal. The stem is filled with lead which was possibly the reason why, at some former time, it has been necessary to refasten it on to the foot.

SILVER PLATED PLATE. Diam. 9 in.

This is quite plain, and is made of copper, silver plated. In its centre is the sacred monogram with a cross, within a circle of glory.

The silver cup is now considered as belonging to Stapleton church. It was formerly the only cup for the three parishes of Barwell, Stapleton, and Potters Marston, until the new plate was given to Barwell in 1847.

POTTERS MARSTON.

The Stapleton communion plate is used here.

CADEBY.

SILVER CUP AND COVER PATEN. Weight of cup 7.3 oz. Height $7\frac{1}{8}$ in. Diam. of bowl $3\frac{3}{8}$ in.; of foot $3\frac{1}{4}$ in. Height of stem $3\frac{5}{8}$ in. Date 1843.

London hall marks.

This little cup has a straight-sided bowl with a raised lip, a thin stem divided in half by a round knob, and a plain round foot. On the bowl is the sacred monogram with a cross and three nails, within a circle of glory.

SILVER COVER PATEN. Weight 1.5 oz. Diam. $3\frac{3}{8}$ in. Date 1843.

This paten, which fits on to the cup both ways, has a round top surmounted by a plain cross.

SILVER PLATED DISH. Diam. 9 in.

This is a plain dish, with the sacred monogram, cross, and three nails within a circle of glory in the centre.

PEWTER FLAGON. Height $10\frac{3}{4}$ in. Diam. at the top $4\frac{3}{4}$ in.; at the foot $6\frac{1}{8}$ in.

Mark. On the bottom inside; a tree within an oval stamp, surrounded by "Samuel Billing."

This is a conical-shaped flagon, swelling straight out from the foot. It has a perfectly flat lid with the edge projecting over the drum.

PEWTER PLATE. Diam. $9\frac{1}{8}$ in.

Marks. 1. C, for Cadeby. 2. In four plain oblongs: (a) Lion passant with three pellets below. (b) A cinquefoil between three pellets. (c) Leopard's head crowned. (d) H. M. 3. X crowned. 4. A conventional flower between two leaves, the sun in splendour between H. M. above, within an oval stamp. 5. Rose crowned between two leaves, within an oval stamp, "London," above.

PEWTER PLATE. Diam. $9\frac{3}{8}$ in.

Marks. 1. X crowned. 2. A seeded rose crowned. 3. A seeded rose, of another shape, crowned. 4. In three square stamps: (a) I. S. (b) A cock. (c) Illegible.

In 1832 there was here, in addition to the three pewter pieces, "an ancient silver cup and top," which were parted with when the modern cup and cover were purchased. The latter were bought by subscriptions raised for the purpose by the Rev. N. P. Small, the late venerable rector of Market Bosworth, who was curate of Cadeby in 1843.*

CARLTON.

SILVER CUP. Weight 4.8 oz. Height $5\frac{1}{2}$ in. Diam. of the bowl $3\frac{1}{4}$ in.; of the foot $2\frac{3}{8}$ in. Height of stem $2\frac{5}{8}$ in. Date circa 1575.

One mark only, a rose.

This is just like others of this series in having a bowl shaped into an inverted truncated cone, concave, with a wide lip and flat projecting base. Round the bowl above the middle, is

* Vide Shenton *infra*.

a double band of stroke ornament $\frac{3}{8}$ in. wide, divided into eight parts by hour-glass curves. The bowl stands upon a narrow evenly-balanced stem, divided in half by a small round moulding between two lines for a knob, swelling out only a little into a vertical edge at each end. The foot, which is flat on the top ends in the usual vertical and flat edges. On the bowl is engraved the sacred monogram within a circle of glory, below which is: "*Carlton Church.*"

SILVER PATEN. Weight 2.5 oz. Diam. $4\frac{7}{8}$ in. Date 1866.

London hall marks.

This paten has been made to fit on to the cup. It has a flat edge, the part within being sunk. In the centre is the sacred monogram within a circle of glory. Underneath is: "*Carlton Church, 1867.*"

SILVER PLATED FLAGON. Height 11 in. Diam. at the top 3 in.; at the foot $4\frac{3}{8}$ in.

This is a straight-sided flagon narrowing to the top, with an R-shaped handle.

SILVER PLATED PLATE. Diam. $8\frac{1}{2}$ in.

This is a plain plate, having round its edge: "*To do good and to communicate forget not.*" In the centre is the sacred monogram within a circle of glory. Underneath is: "*Carlton Church, 1867;*" this, with the monogram being also on the flagon.

PEWTER PLATE. Diam. $4\frac{1}{8}$ in.

No marks.

This is a plain flat plate formerly used as a paten, with a vertical edge $\frac{1}{4}$ in. deep.

PEWTER PLATE. Diam. $8\frac{1}{2}$ in.

Marks. 1. "London." 2. Between two pillars an eagle displayed; "**Bennett**" below.

The silver paten and two plated pieces were bought by subscription for this church during the time that the Rev. **Frederick Fowler Bradford** was curate here, who in 1871 was appointed to the living of Wheathill. The ancient cup was at the same time repaired, the sacred monogram and inscription being then placed upon it.

EARLS SHILTON.

TWO SILVER CUPS. Weight of each 7.8 oz. Height $7\frac{3}{8}$ in. Diam. of the bowl $3\frac{1}{4}$ in.; of the foot $3\frac{1}{2}$ in. Height of stem $3\frac{3}{8}$ in. Date 1853.

London hall marks.

These cups have each a straight-sided concave bowl, rounded off below. On the bowl is engraved the sacred monogram within a star. They each have a round stem, knob and foot.

SILVER PATEN with a foot. Weight 9.4 oz. Diam. 7 in. Diam. of the foot $3\frac{1}{4}$ in. Height of the foot $1\frac{3}{4}$ in. Date 1853.

This paten is flat with a small raised edge. In its centre is the sacred monogram within a star. It has a plain hollow foot.

SILVER FLAGON. Weight 19.8 oz. Height $12\frac{1}{2}$ in. Diam. at the top $1\frac{3}{8}$ in.; at the foot $4\frac{1}{8}$ in. Date 1855.

London hall marks.

This is a jug-shaped flagon of the usual modern shape. Round its middle is: "*Glory be to God on high.*" It has a wide handle ornamented with a band of foliage. Its lid is surmounted with a finial.

SILVER PLATED CUP. Height $7\frac{1}{4}$ in. Diam. of bowl, of foot, and height of stem $3\frac{3}{4}$ in. .

This is a copper cup silver plated. It has a straight-sided bowl with a bell-shaped lip, a plain round stem with a small knob, and a raised round foot. It was probably made early in this century.

PEWTER FLAGON. Height $10\frac{1}{4}$ in. Diam. at top $4\frac{1}{2}$ in.; at foot $5\frac{7}{8}$ in.

Marks. 1. At the top of the drum, V.R. crowned, a mullet between the letters. 2. On the bottom inside, P. M. in an oblong.

This is a straight-sided flagon narrowing towards the top, having a round top to its lid, and a handle of the usual shape. A shallow moulding runs round the edge at the top, round the middle of the drum, and also round the foot.

PEWTER PLATE. Diam. $8\frac{3}{4}$ in.

Marks. 1. "From London." 2. Three lion's heads erased with "**Dunan**" below.

This is of the usual shape.

PEWTER PLATE. Diam. $7\frac{7}{8}$ in.

Marks. 1. In four small shapes: (a) W. S., a pellet between. (b) A buckle. (c) A head. (d) Lion passant. 2. "W. S.," within a heart.

This plate was evidently made to be used as a paten. It has a deep vertical edge, the middle part being flat.

According to Archdeacon **Bonney**, the communion service of Earls Shilton in 1832, consisted of the pewter flagon and two plain silver cups. These cups had vanished before 1854, for at that date the plated cup and pewter vessels formed the only communion service in use in this parish.

ELMSTHORPE.

BRASS CUP. Height $7\frac{3}{8}$ in. Diam. of the bowl $3\frac{1}{2}$ in.; of the foot $4\frac{3}{4}$ in. Height of the stem 5 in.

This cup has a globular bowl, a plain round stem with a round knob, and a wide round foot with a raised moulding round the edge.

BRASS PATEN. Diam. $5\frac{3}{4}$ in.

This paten fits on to the cup, it has a wide flat edge the middle part being sunk.

BRASS FLAGON. Height $11\frac{3}{4}$ in.

This is a jug-shaped flagon standing on a plain round foot; its lid being surmounted by a double cross. These three pieces, which are each lacquered outside and silver plated within, form a very useful and inexpensive kind of communion service until something better can be procured.

The silver service was presented to Earls Shilton, and that of brass to Elmsthorpe, by the Rev. **Ferdinand Ernest Tower**, fifth son of **Christopher**

T. Tower, J.P., D.L., of Weald Hall, Essex, by **Harriett**, second daughter of Sir **T. Beauchamp Proctor**, Bart. Mr. **Tower** was born on 4th Oct., 1820. He graduated from St. John's Coll., Camb., and received deacon and priests orders in 1844 and 1845. In 1854 he was presented to the livings of Elmsthorpe and Earls Shilton, which he accepted in preference to a more lucrative benefice that had been procured for him in Yorkshire. While here



Fig. 49. 1608. $\frac{3}{4}$ full size. M. P. del.

of the former is assistant curate of St. Andrew's, Leicester.

he collected funds for rebuilding the whole of Earls Shilton church, except the tower and spire, and for the restoration of the chancel of Elmsthorpe, which had been for many years, as much of the church still is, in ruins: he also built the vicarage house. In Jan., 1882, Mr. **Tower** was presented to the rectory of Guildford, (Holy Trinity, and St. Mary,) which he held till his death on 21st Jan., 1885: he was buried at St. Leonard's-on-Sea, a chalice by his own desire being carved upon his tombstone.

The Rev. **F. E. Tower**, married on 3rd Oct., 1861, **Mary**, youngest daughter of **William John Campion**, Esq., of Danny Hall, Sussex, by which lady, who died on 26th Nov., 1874, and was buried at Earls Shilton, he had five sons and two daughters; one

HIGHAM-ON-THE-HILL.

SILVER CUP WITH COVER PATEN. Weight of cup 6.2 oz. Height $6\frac{1}{2}$ in. Diam. of bowl $4\frac{1}{2}$ in.; of foot 3 in. Height of stem $2\frac{3}{4}$ in. Date 1608. (FIG. 49.)

One mark only, the maker's; a rose.

This cup is an excellent example of the "rose" marked series. Its bowl has the usual truncated cone very slightly concave, having a wide lip, and flat projecting base. Round the bowl is a band of stroke ornament divided into six parts by hour-glass curves. There is the usual evenly-balanced stem, divided in half by a shallow knob swelling out only a little into each end. The foot is of the usual shape, reeds run round its edge, as well as round both ends of the stem.

SILVER COVER PATEN with a foot. Weight 3.2 oz. Diam. $4\frac{1}{2}$ in. Diam. of the foot $1\frac{1}{2}$ in. Height of foot $\frac{3}{4}$ in. Date 1608. (FIG. 50.)

No marks.

This cover paten is of the same shape as those of Elizabethan date. It is only slightly sunk. Round the top is a band exactly the same as that round the bowl of the cup, with the exception of its being divided by only four hour-glass curves. The foot is a disk attached to the paten by a thick round stem, swelling out a little at both ends. On the foot is, "For the towne of Hyhom in Lester S.;" In the centre is the date "1608." The engraving on both cup and cover is very clear and sharp.

It is of course possible that the cover may be of later date than the cup; but when seen together they have every appearance of having been made at the same time. They may be taken, I think, as evidence in favour of the opinion, that the "rose" was used as a maker's mark for some 30 years or more.



Fig. 50. 1608. $\frac{2}{3}$ of full size. M. P. del.

TWO SILVER PLATED PLATES. Diam. of each 9 in.

These are both plain plates. In the centre of each is the sacred monogram, with a cross above, and three nails below, within a circle of glory.

SILVER PLATED FLAGON. Height 10 in. Diam. at the top $3\frac{1}{2}$ in.; at the foot $5\frac{3}{8}$ in.

This is a straight-sided flagon narrowing to the top.

In the terrier of 1828, the church plate is thus recorded, "one silver cup; one silver salver for collecting alms, and one paten." The salver was not here in 1832.

HINCKLEY.

SILVER CUP. Weight 20.4 oz. Height $8\frac{3}{4}$ in. Diam. of the bowl $4\frac{1}{2}$ in.; of the foot $4\frac{3}{4}$ in. Height of the stem $4\frac{3}{8}$ in. Date 1658. (PLATE 33.)

Hall marks. 1. Capital old English A in a plain shield; this is the damaged A. 2. Lion passant. 3. Leopard's head crowned; each of these two having an outer line following its outline. 4. A greyhound sejant gorged, an annulet showing at the back of the collar, within a shaped shield; the mark of the silversmith who made the Staunton Harold communion plate.*

The bowl of this cup is straight-sided, swelling out a little towards the lip, and ending in a flat base. A disk $2\frac{1}{2}$ inches in diameter cuts through the stem near the top, below which

the stem begins to swell gradually out, ending in a plain foot, which has a hollow rounded edge. The lion passant is repeated underneath. In front of the bowl is this coat of arms: *Sable on a bend Argent three pheons Gules*. Crest: *A cock Argent guttée de sang, beaked, combed, and membered Or*; **Johnson**. The arms divide in half this inscription: "*The gift of Constance Wightman, late wife of John Wightman, to the parish church of Hinckley, 1659.*"

SILVER CUP. Weight 20.3 oz.

Like the first in every respect. Both cups are of very solid construction.

SILVER PATEN with a foot. Weight 16.1 oz. Diam. $8\frac{3}{4}$ in. Diam. of the foot $3\frac{1}{2}$ in. Height of the foot $1\frac{1}{4}$ in. Date **1639**.

Hall marks. 1. Court hand B in a plain shield.* 2. Lion passant. 3. Leopard's head crowned; each of the two last having an outside line following its outline. 4. N. H., a bird below, within a heart-shaped shield; the letters are very indistinct.

This paten has a flat edge $1\frac{3}{4}$ of an inch wide, the middle part being sunk flat to the depth of $\frac{1}{2}$ of an inch. The foot is a disk attached to the paten by a stem 1 inch thick swelling out at both ends. The lion passant is repeated on the foot. On the edge of the paten is the same coat of arms and crest as that on the cup, dividing in half this inscription: "*A testimony of the good will of Constance Wightman late wife of John Wightman to the parish church of Hinckley, 1639.*"

SILVER PATEN with a foot. Weight 12 oz. Diam. $8\frac{3}{8}$ in. Diam. of the foot $3\frac{1}{2}$ in. Height of the foot $1\frac{1}{4}$ in. Date **1658**.

Hall marks as on the cups.

This paten is like the other in shape. On its edge is the same coat of arms and inscription as that on the cups.

SILVER PLATED FLAGON. Height $10\frac{3}{8}$ in. Diam. at the top $3\frac{3}{8}$ in.; at the foot $5\frac{1}{2}$ in.

This is a straight-sided flagon narrowing towards the top. It is of modern make.

In the terrier of 1709 the above silver pieces are mentioned and also "two great flagons of pewter;" these latter were not here in 1832.

Constance Wightman, the donor, at two different times, of the silver service, was the daughter of the Venerable **John Johnson**, D.D.,† of Abbotes Anne, co. Hants, and Archdeacon of Worcester from 1598 to 1610. She married **John Wightman**, citizen and grocer of London, a native of Hinckley, and a member of a family long connected with this place, and also with its hamlet Wykin. **John's** younger brother, **Thomas Wightman**, by marriage became possessed of a property in Peckleton.‡ In his will, dated 22nd Sep., 1636, and proved close to 1639, **John Wightman** left £50 to the poor of Hinckley which was spent in the purchase of a close in Earls Shilton of $2\frac{1}{2}$ acres.§ His widow, **Constance**, probably died soon after making her last gift of plate to this church. Why she placed on her

* This letter is the same in shape but smaller in size than that figured in O. E. P. † Visitation of London. *Hart, Soc.*, Vol. xvii., pp. 14 and 350. ‡ *Nichols*, Vol. iv., p. 876. § *Ibid.* p. 703, where his will is quoted, but which I have failed to find in spite of a search made in many places.

gift the arms of **Johnson** only, cannot be said; they are the same as those claimed by her family at the visitation, but disallowed by *Richmond Herald*. The arms of **Wightman** are: *Per fesse Or and Sable a manuche counterchanged*. Crest; *A stag at gaze Argent, collared chained and attired Or*.

TRINITY CHURCH. HINCKLEY.

TWO SILVER PLATED CUPS. Height of each $8\frac{1}{4}$ in. Diam. of the bowl $3\frac{1}{2}$ in.; of the foot $3\frac{3}{8}$ in. Height of the stem 4 in.

These cups have straight-sided bowls. In front is the sacred monogram with a cross, within a circle of glory. They have narrow round stems rising out of plain round feet.

SILVER PLATED PATEN. Diam. $9\frac{1}{2}$ in.

This paten has a wide raised edge. In its centre is the sacred monogram with a cross, within a circle of glory.

SILVER PLATED FLAGON. Height $9\frac{3}{4}$ in. Diam. at the top $4\frac{3}{4}$ in.; at the foot $4\frac{1}{4}$ in.

This flagon is straight-sided in its upper part, bulging out below. It stands on a round stem, rising out of a plain round foot; on one side is the sacred monogram with a cross within a circle of glory.

This communion service, made of copper, silver plated, was given to this church in 1841 by the late Mrs. **Frewen Turner**, the church itself having been built and endowed by her three years previously.*

KIRKBY MALLORY.

SILVER CUP. Weight 23.8 oz. Height $11\frac{3}{4}$ in. Diam. of bowl $4\frac{1}{4}$ in.; of foot $5\frac{3}{8}$ in. Height of stem 8 in. Date **1768**. (PLATE 33.)

Hall marks. 1. Capital old English N in a square shield. 2. Leopard's head crowned in a rounded shield. 3. Lion passant in a plain oblong. 4. F. B. N. D. in a plain square; the mark of *François Butty and Nich. Dumee*.

This cup has a small bell-shaped bowl supported by a very tall and thick baluster stem, which rises out of a plain round foot. On the bowl is engraved the sacred monogram, with a cross and three nails, within a circle of glory. Round the upper and lower edge of the stem is a gadrooned edge, the same ornament running round the top of the foot. On one side of the foot are these arms; *Quarterly. 1 and 4. Or, fretty Gules, a canton Ermine; Noel. 2. Sable, a chevron between three leopards' faces Or; Wentworth. 3. Gules, on a chief indented Sable three martlets Argent; Lovelace.* Supporters; *Two griffins Argent, collared Or.* Above the shield is a Viscount's coronet, below is the motto "*Penses à Bien*;" the arms of **Noel**, Viscount **Wentworth**,



Fig. 51.

* See Sapcote, p. 348.

of Whellesburgh. (FIG. 51.) On the opposite side of the foot are the arms of **Noel**; *impaling*; *Azure, a chevron engrailed between three birds Or*; **Whitlock**. (FIG. 52.)



Fig. 52.

TWO SILVER PLATES. Weight of each 12.1 oz. Diam $8\frac{3}{4}$ in. Date 1768.

Hall marks. As on the cup.

These are plain and solid plates with gadrooned edges. Each has a raised boss in its centre, on which is the sacred monogram as on the cup; and on the edge of each are the arms of **Noel**, Viscount **Wentworth**. (FIG. 51.)

SILVER FLAGON. Weight 41.3 oz. Height $13\frac{3}{4}$ in. Diam. at the top $3\frac{3}{8}$ in.; at the foot $5\frac{3}{8}$ in. Date 1768. (PLATE 33.)

Hall marks. As on cup.



Fig. 53.

This is a large and handsome jug-shaped flagon with a spout at the top. It has a round raised lid, surmounted by an ornamental knob. Its foot is the same in shape as the foot of the cup. In front is the sacred monogram. On one side of the foot are the arms of **Noel**, Viscount **Wentworth** (FIG. 51); and on the opposite side; *Argent, a bend engrailed between two bundles Sable*; **Clobery**; *impaling*; *Argent, on a chevron Azure between three pelicans vulning themselves Sable, as many cinquefoils Or*; **Cranmer**. (FIG. 53.)

There is every reason for concluding that this valuable service of communion plate was made for the donor and given to this church not later than 1768-9. The donor of it was therefore Sir **Edward Noel**, 6th Bart., and 1st Viscount **Wentworth**, of Whellesburgh, co. Leicester, the representative of the elder existing branch of the ancient family of **Noel**; he being descended from **John**, eldest son of **Andrew Noel**, of Dalby-on-the-Wolds, in this county, whose second son, Sir **Andrew Noel**, Knt., of Dalby, and Brooke, co. Rutland, is the ancestor of the **Noels**, of Exton, Earls of **Gainsborough**. This elder branch obtained estates in Kirkby and Whellesburgh, through the marriage of the above **John Noel**, with **Anne**, daughter and heir of **John Fowler**, of Whellesburgh. Their descendant, Sir **Edward**, was the eldest son of Sir **Clobery Noel**, 5th Bart., by **Elizabeth**, daughter of **Thomas Rowney**, of Oxford, and was born on 30th Aug., 1715. He succeeded his father to the baronetcy and estates, and also inherited the barony of **Wentworth**, of Nettlested, co. Suffolk, at the death, unmarried, of **Martha Lovelace**, Baroness **Wentworth**, in 1745. On 5th May, 1762, he was created Viscount **Wentworth**, of Whellesburgh. Lord **Wentworth** died on 31st Oct., 1774, and was buried at Kirkby Mallory. He married at Wilbye, co. Northants, on 20th July, 1744, **Judith**, only daughter and heir of **William Lamb**, of Farndish, co. Bedford, which lady died on 3rd Dec., 1761, and was buried at Kirkby Mallory, having borne

her lord one son, **William**, 2nd Viscount **Wentworth**, who died in 1815 without issue, and three daughters, the eldest of whom, **Judith**, married Sir **Ralph Milbanke**, Bart., whose only child, **Anne Isabella**, wife of Lord **Byron**, the poet, ultimately inherited the barony of **Wentworth** and the estate of the **Noels**, in this parish. Lord **Byron's** only child, **Ada Augusta**, married **William**, 8th Lord **King**, and 1st Earl of **Lovelace**, the present owner of Kirkby Mallory; their second, but eldest surviving son, **Ralph Gordon Noel**, has inherited the ancient barony of **Wentworth**, of Nettlested.*

In addition to his own arms, Viscount **Wentworth** placed on the silver cup the arms of his great uncle, Sir **Thomas Noel**, Bart., impaling those of his wife, (FIG. 52.) she being **Anne**, daughter of **William Whitlock**, of Phillis Court, Henley-on-Thames. Sir **Thomas** died without issue.

And on the flagon are the arms of Sir **John Clobery**, Knt., of Winchester, impaling those of his wife, (FIG. 53.) she was **Anne**, third daughter and co-heir of **William Cranmer**, the grandson of Archdeacon **Edmund Cranmer**, brother of the Archbishop. Lord **Wentworth** was entitled to quarter the arms of **Clobery** and **Cranmer** with his own, since his grandfather, Sir **John Noel**, married **Mary**, 4th daughter and co-heir of Sir **John Clobery**, by **Anne Cranmer**; their 3rd daughter, **Susannah**, married Sir **Thomas Trollope**, Bart., whose family therefore quarter the same arms. Readers of "*The Chesters of Chicheley*," will remember that it is therein related by Mr. **R. E. Chester Waters** that the arms of **Cranmer** were changed by **Henry VIII.**, who ordered the Archbishop to adopt the coat engraved on this flagon; "*the King declaryng that those birdes shoulde signifie to hym that he oughte to be readie as the pellicane ys to shede his bloude for his yonge ones brought up in the faith of Christe.*"†

MARKET BOSWORTH.

SILVER CUP. Weight 7.9 oz. Height $6\frac{3}{8}$ in. Diam. of bowl $4\frac{1}{2}$ in.; of foot $3\frac{5}{8}$ in. Height of stem $2\frac{3}{4}$ in. Date circa 1575. (PLATE 31.)

One mark only. A rose.

This cup is rather larger than others of the "rose" series, but is otherwise much the same. Its bowl is shaped into an inverted truncated cone, concave, with a flat projecting base. Round it is a band of foliage, divided into four parts by curves double twisted. The stem is evenly balanced, cut in half by a small moulding between two lines for a knob. The foot is flat and wide.

(a)

SILVER GILT CUP. Weight 17.5 oz. Height $7\frac{7}{8}$ in. Diam. of the bowl $4\frac{1}{2}$ in.; of the foot $4\frac{3}{8}$ in. Height of stem 3 in. Date 1683. (PLATE 32.)

Hall marks. 1. Small black letter F in a plain shield. 2. Leopard's head crowned in a circle. 3. Lion passant in a plain oblong. 4. I. D. crowned in a plain shield.

This is a very massive cup with a straight-sided bowl, having a flat base and a slightly bell-shaped lip. It has a thick plain round stem, swelling out to the bowl, and plain flat foot, under which the lion passant is repeated. On the bowl is: "*Market Bosworth ex Dono.*"

* For pedigrees of Noel, see *Nichols*, Vol. iii., p. 254, and Vol. iv., p. 770; also *Hist. of Market Harborough*, by Rev. J. H. Hill, F.S.A., p. 217. † Page 382.

(b)

SILVER GILT FLAGON. Weight 64.2 oz. Height 15 in. Diam. at top 4 in.; at foot 5½ in. Date 1712. (FIG. 54.)



Fig. 54. 1712. Rather more than ½ full size. M. P. del.

co. York. 7. *Paly of six Sable and Argent*; Middleton of Middleton. 8. *Argent, a mullet pierced*

Hall marks. 1. Court hand R. 2. Lion's head erased. 3. Britannia. 4. W. I., two mullets of six points above, a fleur-de-lis below, within a shaped oblong; the mark of *David Willaume*, in the Pell Mell.

This is a large and handsome jug-shaped flagon, much enriched with repoussé ornament. Round its middle are four cherubs, between each of which is a festoon of corn, grapes, and other fruit; below is a band of acanthus and lotus leaves placed alternately; an acanthus leaf band runs round both the foot and lid, the latter being surmounted with a cross patée. The handle is shaped into two curves. On one side of the flagon is this coat of arms: *Or, on two bars Gules three water-bouquets Argent*; Willoughby. On the opposite side, this coat: *Azure a lion rampant and chief Or*; Dixie; *impaling*; Quarterly. 1. Willoughby. 2. *Vert, three stags tripart Or*; Rotheram. 3. *Gules, three bars Argent*; Pusey, of Selston. 4. *Argent, a chevron engrailed between three trefoils slipt Sable*; Clay,* of Crich. 5. *A saltire engrailed between four fleur-de-lis*; Calton.† 6. *Ermine on a fesse Gules three annulets Or*; Barton of Fryton,

* For Pedigree of Clay, vide *Reliquary*, Vol. x., p. 254. † *Nichols* (Vol. iv., p. 500) describes a hatchment in this church, to Sir Wolstan Dixie, 4th Bart., bearing many quarterings including those on these flagons; he ascribes however several to the wrong families. This 5th one he blazons thus; *Sable a saltire between four crosslets Or*. In the engraved coat of arms, of which FIG. 55 is an exact copy, the bearings look more like fleurs-de-lis than cross crosslets.

*Sable; Assheton.** 9. *Argent, on a bend between six martlets Gules three bezants; Wortley of Wortley.* (FIG. 55.)

SILVER GILT FLAGON. Weight 63.1 oz.

In all respects the same as the last.

(c)

SILVER PATEN with a foot. Weight 9.6 oz. Diam. 8 in. Diam. of foot $3\frac{3}{8}$ in. Height of foot $1\frac{3}{4}$ in. Date 1680.

Hall marks. 1. Small black-letter C in a plain shield. 2 and 3, as on last cup. 4. I. W. in a shaped oblong.

This is a flat paten, with a raised gadrooned edge. The foot is a drum 2 in. thick, swelling out into a gadrooned edge; the lion passant is repeated underneath. In the centre of the paten is this coat of arms: *Dixie; impaling Azure, three bars Argent, in chief three bezants; Atkins.* (FIG. 56.) Below is: "*Given by Rebecca Dixie, 1694.*"

(d)

SILVER PLATE. Weight 7.6 oz. Diam. $8\frac{1}{8}$ in. Date 1763.

Hall marks. 1. Capital old English H in a square shield. 2. Leopard's head crowned in a rounded shield. 3. Lion passant in a plain oval. 4. E. A., a mullet between the letters, in a plain oblong.

This plate, originally a dinner plate, is pentagonal in shape, having a gadrooned edge. Underneath is: "*Frances Dixie.*"

On a fragment of a terrier signed by **John Dixie**, rector, and probably made in 1709, the church plate then here is mentioned thus: "One large silver cup $17\frac{1}{2}$ oz., inscription: '*Market Bosworth Ex Dono*'; one lesser silver cup $12\frac{1}{2}$ oz. with a cover, no inscription; one silver salver or paten 9 oz. 16 dwts., given by **Rebecca Dixie**. The flagon is pewter." The cover paten belonging to the oldest cup was not here in 1832.

(a)

A tradition in this parish exists, as I was informed by the late rector, to the effect that the silver gilt cup was the gift of the Rev. **John Dixie**, rector here from 1685 to 1719. The same fact is mentioned by Archdeacon **Bonney** in 1832.

(b)

The two flagons were bequeathed to this church by **Mary, Lady Dixie**,



Fig. 55.



Fig. 56.

in this clause of her will, made 9th Jan., 1709, and proved at York with a codicil, dated 11th Jan., 1709, on the 4th Jan., 1710-11: "*I will and direct that the sum of £100 of lawful money of Great Britain shall be laid out by my executor at his discretion for the buying a pulpit cloth, cushion, and carpet of purple velvet for the pulpit and communion table at Market Bosworth aforesaid; and for two silver flagons to be used as communion plate in the Church and Chancel there; and that the said pulpit cloth, cushion, carpet, and plate, be used there as long as the same endure.*" This lady was **Mary**, the only daughter of **William Willoughby**, of South Muskham, Notts, by **Elizabeth**, daughter and co-heir of **Timothy Pusey**, of Selston, Notts, and was born in about 1630. She married in about 1654, Sir **Beaumont Dixie**, 2nd Bart., by whom she eventually had several sons and daughters.* On the death on 10th Feb., 1670, of her only brother, Sir **William Willoughby**, 1st and last Bart., Lady **Dixie** became his heir, and inherited the property at Selston which had belonged to their mother, and also an estate at Crich, co. Derby, which had been brought into their family by their maternal grandmother, **Mary**, daughter and heir of **John Clay**, of that place. Sir **Beaumont Dixie**, died in May, 1692.

In his will, made 23rd Feb., 1688, and proved in Leicester, on 12th May, 1692, Sir **Beaumont Dixie**, Bart., left: all manors, messuages, lands etc., in Market Bosworth, Coton and Carlton, co. Leicester, and in Normanton, co. Derby, with the advowson of St. Peter's vicarage, in Derby, and the advowson of the rectory of Market Bosworth, to his son **Wolstan** and other sons in tail male; to wife **Mary**, jewels usually in her custody, and all goods in houses at Normanton and Selston; all other goods and plate to her use for life; to son **Wolstan**, "study of books"; to daughter **Godolphin**, £1000; to daughter **Frances**, £1500; to daughter **Margaret**, £1500; son **William**, £1000; son **Richard**, £1000; poor of Market Bosworth £10; all rest of personalty and all goods and plate that have been left to wife for life, after her death, to be divided equally between daughters, **Elizabeth Godolphin**, Lady **Mary Willoughby**, **Frances Dixie**, **Margaret Dixie**, and sons, **Beaumont**, **John**, **William** and **Richard**. Wife sole executrix: overseers, brother-in-law **Thomas Pochin**, of Barkby, and friend **Roger Rooe**, of Normanton Turville; to those two the next presentation of rectory of Market Bosworth in trust, they to appoint such fit person as son **John Dixie** shall name in writing or in last will.

After her husband's death, Lady **Dixie** lived at Selston, where she died, and from whence she was brought to Market Bosworth to be buried, on the 2nd of Dec., 1710.†

In addition to this bequest to the church, Lady **Dixie** left £10 to the poor of Market Bosworth, and the same sum to the poor of Selston; to the poor of Normanton, near Derby, and to the poor of Crich £5 each. She also left in trust to her son, **John Dixie**, rector of Bosworth, whom she appointed her sole executor, and to her son **Richard Dixie**, their heirs and assigns, the manor of Crich, the Hall, and a piece of ground called "the Acre;" from the profits of which they were ordered to pay £3 a year to the vicar of Crich, and to lay out the rest of the income

* For pedigree, see *Nichols*, Vol. iv., p. 506.

† Parish Register.

in the repair of the chancel there, and in preserving and repairing the monuments in the church of that parish.

The arms of **Dixie** impaling **Willoughby** are on the West front of Market Bosworth hall.

(c)

The silver paten was given by **Rebecca**, the tenth and youngest child of Sir **Richard Atkins**, 1st Bart., of Clapham, Surrey,* by **Rebecca**, daughter of Sir **Edmund Wright**, of London, Knt. Although this lady was probably born, married, and buried, at Clapham, no entry relating to her can be found in the registers of that place, in which are several gaps. Judging from the ages of her children, **Rebecca Dixie** presented the paten to this church at the time when she was married to **Wolstan Dixie**, Esq., the eldest son of the above Sir **Beaumont** and **Mary Dixie**, who was born in 1657, and at the death of his father, succeeded as 3rd Bart. Sir **Wolstan** was Lieut.-Colonel of the Leicestershire Militia, and was buried at Market Bosworth, on 18th Dec., 1713.†

In his will, dated 22nd Oct., 1713, and proved in Leicester, on 26th Jan., 1713-4, Sir **Wolstan Dixie** left to his wife "my mother **Atkins**' picture and her own little picture;" to his eldest son **Wolstan**, all land and premises in fields of Derby, lately bought of **Thomas Carter** and **Abraham Crompton**, both of Derby, gents.; also five closes of pasture called **Deepholmes**, in Cadeby, bought of **Thomas Handley**, of Market Bosworth, said son to pay to executrix £200; bulk of personalty in equal shares to five younger daughters, **Barbara**, **Elizabeth**, **Frances**, **Bridget**, and **Annabella**, **Dixie**, each to have her share at 21, or at marriage; wife **Rebecca**, sole executrix; overseers: **Charles Jennens**, of Gopsal, Esq., and **Jeffery May**, of Sutton Cheney, gent.

After his death, his widow, **Rebecca**, Lady **Dixie**, seems to have retired to her native parish of Clapham, where, according to *Nichols*, she was buried in 1714.

She and her husband are mentioned in the inscription on the monument to her father unearthed from the vaults under Clapham church at the end of 1885; belonging to which is a little figure of the second daughter of Sir **R. Atkins**, also named **Rebecca**, who had died in 1661, aged 9.

(d)

Frances Dixie, the giver of the silver plate to this church, was the granddaughter of the donor of the two flagons, being one of the seven daughters of Sir **Wolstan Dixie**, 3rd Bart., and **Rebecca**, his wife. She was baptized at Market Bosworth, on the 22nd of July, 1696,† and died unmarried in the 91st year of her age; being buried in this church on the 20th May, 1787.† In her will, made 27th Sep., 1785, and proved with four codicils, 19th June, 1787, P.C.C., **Frances Dixie**, is described as spinster, of Market Bosworth. She bequeathed a large number of legacies in money,

* For pedigree of this family see *Burke's Extinct Baronetages*.

† Parish Register.

plate, etc., to many relations and friends. Her executors were, her nephew, **Willoughby Dixie, Esq.**, and **George Pochin, Esq.**, who married her niece.

BARLESTONE.

TWO SILVER ELECTRO-PLATED CUPS. Height of each 8 in. Diam. of bowl $4\frac{1}{4}$ in.; of foot $5\frac{1}{4}$ in. Height of stem $5\frac{1}{4}$ in.

These cups have V-shaped bowls, round stems with large round knobs and plain round feet. On a band round the bowl are these words: "*This is my blood.*" The sacred monogram is engraved upon their feet.

TWO SILVER ELECTRO-PLATED PATENS. Diam. of each 7 in.

These patens have wide flat edges, the middle being sunk flat. Round the edge of each is: "*Take, eat, this is my body.*"

TWO PEWTER PLATES. Diam. of each $9\frac{3}{4}$ in.

Marks. 1. "Made in London." 2. Rose crowned. 3. A lion passant with a crown above; above is "**Robert**;" an illegible name below.

Until the year 1855 there was here an ancient silver cup and small silver paten. These were unfortunately sold at that date, the electro-plated pieces being then bought. That was the year in which the church was restored.

SHENTON.

(a)

SILVER CUP. Weight 10.5 oz. Height $5\frac{1}{2}$ in. Diam. $4\frac{3}{8}$ in.; of foot $3\frac{1}{8}$ in. Height of stem $3\frac{1}{8}$ in. Date **1641.** (FIG. 57.)

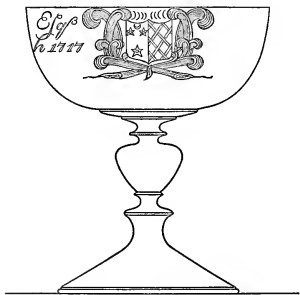

Fig. 57.

covered once the greater part of the bowl; constant cleaning has worn much of it off.

Hall marks. 1. Court hand D in a plain shield. 2. Lion passant. 3. Leopard's head crowned; each in a shaped outline. 4. W. C., perhaps a rose below, in a shaped stamp.

This cup, made of very thick metal, is a late example of a tazza, the only other specimen in this county being an earlier one at Peatling Magna.* It has a wide shallow bowl, baluster stem and flat sloping foot, underneath which are the lion passant and the initials "G. S." On the bowl is this coat of arms: *Argent, three mullets pierced Sable, a crescent for difference; Wollaston; impaling, Azure, fretty Argent; Cave.* On one side of the arms is: "*The gift of William Chester, Esq^r to Shenton Church 1717.*" Under the bowl are distinct traces of an engraved ornament,

* Plate 28.

(b)

SILVER CUP. Weight 15.2 oz. Height $7\frac{3}{4}$ in. Diam. of the bowl $3\frac{1}{2}$ in.; of the foot $4\frac{7}{8}$ in. Height of stem 5 in. Date 1861.

London hall marks.

This cup has a globular bowl, hexagonal stem and knob, and a foot shaped into six lobes, on one of which is the sacred monogram. The knob is ornamented with six diamond shaped bosses, between each of which is open tracery.

SILVER PATEN. Weight 3.4 oz. Diam. $6\frac{1}{2}$ in. Date 1860.

This paten has a flat edge, the middle part being sunk in a six-lobed depression. In the centre is the Agnus Dei within a circle gilt; and round the edge is: "*O Lamb of God that takest away the sins of the world, have mercy upon us.*" Underneath the paten is: "*This communion plate was an offering from the Rector and congregation on the first Sunday of the opening of Shenton New Church, August 4th, A.D. 1861.*"

SILVER FLAGON. Weight 18.5 oz. Height $11\frac{1}{4}$ in. Diam. at the top $2\frac{1}{4}$ in.; at the foot 4 in. Date 1861.

This is a jug-shaped flagon, having round its middle: "*Glory be to God on high.*" Its handle terminates at each end in a fleur-de-lis.

PEWTER ALMS DISH. Diam. $12\frac{1}{8}$ in. Depth $1\frac{1}{2}$ in. Date circa 1700.

Marks. 1. X crowned. 2. "London" in plain oblong. 3. Seeded rose crowned between two palm leaves. 4. A tree between I. S., between two palm leaves. 5. In four small plain shields (a) W above W between three mullets. (b) Chess pawn between three mullets. (c) Leopard's face between three mullets. (d) Illegible.

This is a plain basin with a flat edge, on which is: "*A gift of Mrs. Sarah Munk to the Church of Shenton.*"

(c)

PEWTER FLAGON. Height 13 in. Diam. at the top $4\frac{3}{4}$ in.; at foot $6\frac{3}{4}$ in. Date circa 1717.

Marks, in four small shields. 1 and 2. Lion rampant. 3. Buckle. 4. Capital old English C.

This is a tall straight-sided flagon with a raised lid surmounted by a knob, and an R-shaped handle. In front of the drum is the sacred monogram with a cross and three nails in a circle of glory. Under the foot is: "*The Gift of Sarah Beebe to Shenton Church.*"

PEWTER PLATE. Diam. $9\frac{1}{4}$ in. Date circa 1717.

Marks. 1. X crowned. 2. Lion passant and three other indistinct marks, each in a small shape. 3. "London" in an oblong. 4. A globe between two leaves, a lion passant above.

This is a plain plate with the following inscription on its edge: "*The Gift of Mrs. Sarah Beeby to the Church of Shenton, 1717.*"

(d)

PEWTER PLATE. Diam. $9\frac{1}{8}$ in.

Marks. On the edge, S. S. Underneath. 1. X crowned. 2. Golden Fleece within an oval, "Samuel" above, "Ellis" below. 3. On a scroll "S. Ellis, London." 4. In four small shapes: (a) Golden Fleece. (b) Lion's head erased. (c) Britannia. (d) S. E.

This inscription is on the edge: "*The gift of Mrs. E^h. Lea to the Church of Shenton, 1831.*"

(a)

The history of the tazza seems to be this ; it was first of all a drinking cup belonging to some one owning the initials "G. S." The coat of arms shows that it was afterwards owned by **William Wollaston**, Esq., of Shenton, who married in about 1660, **Elizabeth**, daughter and sole heir of Captain **Francis Cave**, of Ingarsby, co. Leicester ;* from whom this cup passed to their grandson **William Chester**, who presented it to the church. This gentleman was the eldest son of Sir **John Chester**, of Chicheley, 4th Bart., by his first wife **Anne**, eldest daughter and co-heir of **William and Elizabeth Wollaston**, and was born here on 5th Sep., 1687. Sir **John Chester** until his second marriage in 1714, made Shenton Hall his home ; his son **William** continued to live here with his grandmother Mrs. **Wollaston** ; and here he was married on 5th March, 1716-17,† to **Penelope**, the eldest daughter of **George Hewett**, Esq., of Great Stretton and Great Glenn. A fortnight after **William Chester's** marriage, his grandmother, **Elizabeth Wollaston** died, when he and his wife had to leave Shenton Hall, since this estate then passed to a distant cousin, **William Wollaston**, the author of "*The religion of nature delineated*;" from whom its present owner **Frederick E. A. Wollaston**, Esq., is directly descended. **William Chester** then took up his abode at Glenn Hall, a house belonging to his wife's family, and before leaving Shenton for good made this farewell gift to the church. On the 6th Feb., 1726, he succeeded his father as 5th Bart., but enjoyed the title for only 32 days, for he died at Glenn on 10th of March, and was buried at Chicheley on the 19th, in the same year. Sir **William Chester**, by his wife **Penelope Hewett**, left six daughters ; the second of whom, **Elizabeth**, ran away with her cousin **John Chester**, of London ; their only child **Dorothea**, married her cousin Sir **George Robinson**, 5th Bart., of Cranford, Northants, and brought to her husband's family the property of the **Hewetts** in Stretton and Great Glenn.‡ Sir **William Chester**, Bart., was the nephew of **Dorothy Wilson**, the donor of plate to Tugby and Loughborough ; § his wife's sister, **Anne Hewett**, bequeathed plate to Glenn church.¶

(b)

The church here was rebuilt chiefly at the cost of **Frederick Wollaston**, Esq., who died in 1879, and of his brother the Rev. **Henry John Wollaston**, of Withington, co. Gloucester, who died in 1869, the father and uncle, respectively, of the present owner of Shenton ; to the memory of the former there is a brass tablet on the East wall of the South transept, the latter being commemorated by a similar tablet on the North wall of the nave.

The three modern pieces of plate were presented in 1861, at the

* For pedigree of Wollaston see *Nichols*, Vol. iv., p. 541, of *Cave*, Vol. iii., p. 290.

† Parish Register.

‡ See *Genealogical Memoirs of the Chesters of Chicheley*, by R. E. Chester Waters, p. 604.

§ Pages 250 and 45.

¶ Page 208.

reopening of the church, by the late rector, the Rev. **N. P. Small**, and his congregation.

The Rev. **Nathaniel Pomfret Small**, was the third son of the Rev. **Henry Small**, of Kidwelly, co. Carmarthen, by **Dorothy**, one of the daughters of the Rev. **Beaumont Dixie**, vicar of St. Peter's, Derby, and was born on 23rd Oct., 1805. He matriculated at St. Mary's Hall, Oxford, on 25th May, 1822, and taking his B.A. degree in 1826 and M.A. in 1829, was ordained deacon by the Bishop of **Peterborough** in 1830, and priest in 1831. Mr. **Small** was in 1847 presented to the rectory of Market Bosworth with the chapelries, by his cousin Sir **Willoughby Wolstan Dixie**, Bart., which he held till his death on 21st May, 1885; he was buried at Market Bosworth. The Rev. **N. P. Small** was twice married; first to **Katherine Hannah**, youngest daughter of the Rev. **William Southworth Lee**, rector of Burton Overy, by **Frances**, daughter of **Richard Dyott**, who died on 30th Oct., 1831, aged 22, and was buried at Burton Overy; secondly to **Bridget**, eldest daughter of the Rev. **John Roby**, rector of Congerstone, by **Dorothy** his wife, who was born at Congerstone in 1800, and died on 10th Oct., 1887, being buried next her husband; over their grave is a recumbent monument, bearing a short inscription to each.

(c)

Sarah Munk, the donor of the pewter dish, was the same person as **Sarah Beebe**, the donor of the flagon and plate. She was twice married; first to **Thomas Munk**, gent., of this parish, to whom she bore three sons; **John**, died 2nd Sep., 1692, aged 3, **Thomas**, died 12th Nov., 1704, aged 14, and **Herbert**, died 15th Jan., 1704-5, aged 20. Mr. **Thomas Munk** died at Shenton, and was buried at Austrey, co. Warwick, on 6th Jan., 1713.* His widow married **William Beeby**, gent., of Shenton, who was buried here in 1721.† **Sarah Beeby**, herself died here, and was buried next her first husband, at Austrey, on 20th Sep., 1723.*

In his will, made 29th July, 1720, and proved P.C.C. on 26th June, 1721, **William Beeby**, of Shenton, gent., left to brother **John Beeby** £40; to "three sisters" **Elizabeth Austin**, **Anne King** and **Joane Hutton** £40 each; to his sister **Dorothy Halsted** £60; to his nephew **John Beeby**, one of the sons of brother **John**, £10; to nephew **William Halsted**, one of the sons of sister **Dorothy**, £40; to nephew **William Barke**, son of my sister **Mary**, by **William Barke**, her first husband, £8; all rest of personalty to wife **Sarah** for life. After her death, to nephews **William**, **George** and **Richard Beeby**, three sons of brother **John**, £100 each; to nieces **Elizabeth Willows**, **Anne Beeby** and **Mary Beeby**, daughters of brother **John**, £40 each; to nephew **Bennett**, a son of sister **Elizabeth Austin**, by former husband, **Thomas Bennett**, £10, and to his brother **Thomas Bennett** £40; to **Joseph Halsted**, son of sister **Dorothy** £40; to niece **Joane Hutton**, daughter of sister **Joane**, £60; to nieces **Elizabeth**, **Alice**, **Anne** and **Dorothy Hutton**, £40 each; to nephews

* Austrey Parish Register; in which church is a tablet to the three sons.

† Parish Register.

William, Mathias and John King, and nieces **Elizabeth** and **Ann King**, five children of sister **Ann**, £40 each; to nephews **George Cook**, and nieces **Mary, Dorothy** and **Elizabeth Cook**, four children of sister **Mary**, by **Richard Cook**, her second husband, £40 each; all rest of personalty, and also personalty late belonging to **Thomas Munk**, wife's first husband, and all real estate after wife's death to nephew **John Beeby**; he and wife **Sarah** executors.

In her will, made 8th Feb., 1721-2, and proved at Leicester 21st Aug., 1725, "**Sarah Beeby**, of Market Bosworth, widow," left to her "niece," **Dorothy Windus** £40, and little wooden box with rings in it; to "sister," **Dorothy Halstead**, trunk marked S.W., furniture, and £20; legacies to friends and servants; all rest of real and personal estate to "kinsman and nephew," **John Beeby**, of Shenton, her executor.

Seal: "*Quarterly*; 1 and 4, a *chevron between three lions' heads erased*; 2 and 3, a *cockatrice*.
Crest: a *cockatrice*."

(d)

Mrs. **Elizabeth Lea**, the donor of the other pewter plate, was the wife of Mr. **Francis Lea**, a member of a family long connected with Shenton, who died in 1828, at the age of 54. Mrs. **Lea** died on 29th May, 1851, in the 68th year of her age. In the churchyard here on the South side of the church, is a large slate slab laid on the ground, to the memory of **Francis and Elizabeth Lea**.

SUTTON CHENEY.

SILVER CUP. Weight 6.2 oz. Height 5 $\frac{5}{8}$ in. Diam. of bowl 3 $\frac{7}{8}$ in.; of foot 3 $\frac{1}{8}$ in. Height of stem 2 $\frac{1}{2}$ in. Date *circa* 1575. (PLATE 31.)

One mark only: a plain cross between four pellets within a dotted circle.

This piece, made by the same maker as the Swepston, (p. 27) and Dadlington (*infra*) cups, is so like those of the "rose" series, that it would certainly have been classed with them if it had not had a mark of its own. It has the same wide lipped bowl with a flat projecting base. Its straight, evenly-balanced stem, is rather thicker than the usual stem of a rose marked cup. Its foot is of the usual shape, with a reeded edge. Round the bowl is a double band of stroke ornament, each divided into five parts by hour-glass curves. The cup was originally gilt, or parcel gilt; traces of gilding are still very visible on the lip, knob, and edge of the foot.

SILVER PLATED PATEN. Diam. 8 $\frac{5}{8}$ in.

This is a plain plate with the sacred monogram and cross, within a circle of glory in its centre.

SILVER PLATED FLAGON. Height 9 $\frac{3}{4}$ in. Diam. at the top 3 $\frac{1}{4}$ in.; at the foot 4 $\frac{3}{4}$ in.

This is a straight-sided flagon narrowing to the top. On one side of it is the sacred monogram.

Both these pieces are modern.

MARKFIELD.

SILVER CUP. Weight 8.7 oz. Height $7\frac{1}{4}$ in. Diam. of the bowl $3\frac{1}{2}$ in.; of foot 3 in. Height of stem 3 in. Date 1814.

London hall marks.

The lower part of the bowl of this cup is egg-shaped, the upper part straight-sided, ending in a raised lip. The stem is a thin round one swelling into a small round knob. On the bowl is: "*Markfield*" in old English letters.

SILVER PLATED PATEN with a foot. Diam. 9 in. Diam. of the foot $4\frac{3}{8}$ in. Height of the foot $3\frac{7}{8}$ in.

This is a plain flat paten with the sacred monogram within a circle of glory in the centre. Underneath is: "*Presented to St. Margaret's church, Markfield, on the day of its reconsecration 19th Dec., 1865, by William Brown, of Clapham, Surrey.*"

SILVER PLATED FLAGON. Height 11 in. Diam. of the top $3\frac{3}{8}$ in.; of the foot $6\frac{1}{4}$ in.

This is a straight-sided flagon narrowing towards the top. On one side of it is the sacred monogram within a circle of glory. Underneath the foot is the same inscription as that on the paten.

TWO PEWTER PLATES. Diam of each $8\frac{1}{2}$ in.

Marks. 1. On an ornamental shield, per chevron engrailed three leopards' faces. 2. On a scroll below, "London." 3. I. A.

These are plain plates with flat edges 1 in. wide.

In the terrier of 1745, the church plate then here is thus described; "one pewter flagon and a pewter plate; one silver cup or chalice with a cover." Neither the ancient cup and cover or pewter flagon were here in 1832.

PECKLETON.

(a)

SILVER CUP. Weight 7.5 oz. Height $7\frac{3}{4}$ in. Diam. of bowl 4 in.; of foot $3\frac{1}{8}$ in. Height of stem $3\frac{1}{2}$ in. Date 1713.

Hall marks. 1. Court-hand S. 2. Lion's head erased. 3. Britannia. 4. P. F., a mullet above and below, in a shaped shield.

This cup has a straight-sided concave bowl with a raised lip; a round stem divided in half by a round knob, and a plain foot ending in a round moulding. The stem swells out at both ends. On the bowl is: "*Ecclesie Parochiali de Peckleton, D.D.D., Thomas Boothby de Tooly armiger. A.D. MDCCLXIII.*"

SILVER FLAGON. Weight 26.4 oz. Height $9\frac{1}{2}$ in. Diam. at the top $3\frac{3}{8}$ in.; at the foot $5\frac{1}{2}$ in. Date 1713.

Hall marks as on cup.

This is a small but solid straight-sided flagon narrowing to the top, having a flat top to its lid. In front is the same inscription as that on the cup.

(b)

SILVER PATEN. Weight 16.7 oz. Diam. 9 $\frac{5}{8}$ in. Date 1737.

Hall marks. 1. Small Roman B in a plain shield. 2. Leopard's head crowned in a plain pointed shield. 3. Lion passant in a plain oblong. 4. A bird with illegible letters below.

This is a plain dish, having in its centre the sacred monogram with a cross and three nails, within a circle of glory. On the back is: "*The gift of Mr. Ch^a. Burdett, to the parish church of Peckleton, in the county of Leicester, 1738. 16. 16.**"

SILVER PLATED TRAY. Diam. 6 $\frac{5}{8}$ in.

This is a salver, hexagonal in shape, with a raised ornamental edge. Underneath are three feet. It was formerly used as a paten; and is mentioned in the list of church goods given by *Nichols* in his account of this parish.

In the parish chest here, is a book containing an inventory of church goods delivered up by one churchwarden to another; the first entry is as follows:

"Delivered to Mr. **Thomas Everard**, Churchwarden, the 18th of April, 1625, the church goods, viz., one Surples & a Table-cloth, a Comunion Cup of Sylver with a cover of Sylver, a pewter flaggen, a Cushen for the pulpitt, a Church bible, & the Comunion booke and a Carpett.

"Churchwardens, Mr. **Thomas Everard**, Mr. **Edward Wells**."

A similar list of goods, naming the same plate, is given till 1670, after which the entries cease. In 1642 a basket is mentioned, which in 1646 is called "a twiggen basket."

In the same book have been entered churchwardens' and overseers' accounts, this entry being found in 1675:

"Scouring the flagon, and cup, and pewter dish £0 os. 6d."

These entries cease in 1705; possibly if the accounts had been kept for eight years longer, we should find that the old cup and cover were sold when Mr. **Boothby** presented new plate. Nothing certain however can be made out with respect to the fate of the old silver and pewter plate, except that none of it was here in 1832.

(a)

Thomas Boothby represented the eldest branch of his family, being descended from the eldest surviving son of **William Boothby**, merchant tailor, of London, in the last half of the sixteenth century, and **Judith**, his wife, who were both such excellent managers that they were able to provide large fortunes for all their sons: the eldest and the fifth died unmarried; from the second sprang the **Boothbys**, of Tooley Park, from the third the **Boothbys**, Barts., of Broadlow Ash, and from the fourth the **Boothbys**, of Potters Marston.† **Thomas**, the donor of these pieces, was the only surviving son of **Thomas Boothby**, of Tooley Park, by his second wife,

* *i.e.*, 16 oz. 16 dwts., not £16 16s., as is given in *Nichols*.

† For pedigrees, see *Nichols*, Vol. iv., p. 177.

Elizabeth, and was baptized at Peckleton on 3rd March, 1680.* He succeeded to his father's estates at an early date, was high sheriff of Leicestershire in 1709, and during most of his life a noted sportsman. **Thomas Boothby** was thrice married; first in 1697, to **Elizabeth**, eldest daughter and co-heir of Sir **Charles Skrymsher**, of Norbury, Knt., who died on 20th Sep., 1704, aged 28, leaving a son, **Thomas**, who succeeded to Tooley Park and Norbury; secondly in 1705, to **Hester**, daughter of **Gerard Skrymsher**, of Woodzeas, Staffs, who died in 1713, aged 25, having borne her husband four sons† and one daughter: and thirdly in about 1715, to **Sarah** — of co. Staffs, who survived her two sons, and was buried at Belgrave, on 31st March, 1766.‡ **Thomas Boothby** died on 2nd Aug., 1752, and was buried in the chancel of Peckleton. The slab formerly over his grave, is now in the tower, as is also one to his second wife; the slab mentioned by *Nichols*, to the first wife, may be there too, but if so, is illegible.

In his will, made 21st Oct., 1738 and proved, with a codicil dated 12th June, 1747, P.C.C. on 13th Nov., 1752, **Thomas Boothby**, "of Tooley Park," left all lands in Leicestershire "which I purchased from Master **John Farmer**, late the estate of Master **Stephen Burditt**, **William Boothby**, Esq., Master **Andrew Glen**, Mistress **Martha Boothby**, **Francis Dann**, **Edward Bierley** the younger, **John Holmes**, — **Middleton**, **Joseph Avery** the elder, **Joseph Avery** the younger" in trust, subject to an annuity of £100 to **Catherine Holmes** for life, to son **William**, eldest son of wife **Sarah**, and his sons, then to **John** and his sons, and then to each of the sons of his wife **Sarah**. All plate and goods at Groby Pool, to **Catherine Holmes** for life, then to son **William**; house and garden at Groby Pool, held by lease from Lord **Stamford**, to **Catherine Holmes** for life, then remainder of term to son **William** and his assigns. In codicil: manor or lordship of Broadlow Ash, co. Derby, and all other land in that county to **Thomas Boothby**, of Marston, Esq., **Blest Colclough**, of Eccleshall, co. Staff, gent., in trust, to be sold, they to buy from proceeds a rent charge of £250 a year for wife **Sarah** for life; they to pay debts, and with $\frac{2}{3}$ of remainder to buy a freehold estate for **William**, the eldest son of wife **Sarah**, with remainder after him to his sons, then son **John Boothby**, youngest son of **Sarah**, to **Gerard Boothby**, and his sons, and then to son **Charles Skrymsher Boothby**; $\frac{1}{2}$ of $\frac{2}{3}$ of said remainder to be spent in purchase of freehold estate for said son **John**, with remainder to **William**, **Gerard** and **Charles Skrymsher**; the other $\frac{1}{2}$ of $\frac{2}{3}$ of said remainder to be spent thus: one moiety to son **Gerard**, the other to daughter **Hester**; all rest of personalty to be divided between his five children, **Charles Skrymsher**, **Gerard**, **Hester**, **William** and **John**. Executor: **Blest Colclough**.

Sarah Boothby, "of Belgrave, widow," in her will made 21st Feb., 1760, and proved in Leicester on 15th May, 1766, left to the poor of Belgrave £5; to Mr. **Thomas Halford**, of the borough of Leicester, gent., £20; all jewels, plate, rings and rest of personalty to Mrs. **Elizabeth**, wife of **James Davenant**, Esq.;§ to servants, **Elizabeth Chesterton** and

* Parish Register. "Thomas, son of Thomas Boothby, Esq., and Magdalaine bap. 17th Aug., 1671; bur. 21st Oct., 1677." "Thomas, son of Thomas Boothby, Esq., and Elizabeth, bap. 3rd March, 1680." † The eldest being Charles Skrymsher Boothby; *Vide* Ratby, page 327. ‡ Parish Register. § And daughter of Thomas Boothby by his first wife Elizabeth.

Robert Hawley, messuage in Belgrave, "lately bought of Mr. **Francis Nedham** and **Elizabeth**, his wife." **Thomas Halford**, executor.

(b)

The donor of the silver dish was the 2nd son of **John Burdett**, by his wife, **Elizabeth Ward**,* and was baptized in this parish on 18th Sep., 1671. He was a member of the family settled for some centuries at Mowsley.† **Charles Burdett** resided at Earls Shilton, a connection between his family and this side of the county having been formed through the marriage of his grandfather, **Richard Burdett**, with **Mary**, the fourth daughter and co-heir of **William Croft**, of Peckleton. He died unmarried, and was buried at Peckleton one year after he had made this gift.

A stone to his memory stands in the churchyard to the East of the chancel wall, on which are his arms: "*Argent on two bars Or six martlets Gules*;" and this inscription: "*In memory of Charles Burdett, late of Stockhouse,‡ who departed this life Aug. 22nd, 1739, aged 69.*"

*"This world's a city full of crooked streets,
Death is a market place where all men meets,
If life were merchandise that men could buy,
Rich men would always live and poor men die."*

In his will, made 15th Aug., and proved at Leicester 13th Oct., 1739, **Charles Burdett**, "of Earls Shilton, gent.," left £1 1s. od. to the poor of Earls Shilton, and the same sum to the poor of Peckleton; and all personalty after payment of debts to his sole executor, **Thomas Boothby**, of Potters Marston, Esq., Seal: arms of **Burdett**. No mention of any real property.

STOKE GOLDING.

SILVER CUP WITH A COVER PATEN. Weight of cup 12.5 oz. Height 8 $\frac{3}{8}$ in. Diam. of bowl 5 in.; of foot 3 $\frac{7}{8}$ in. Height of stem 3 $\frac{3}{4}$ in. Date 1688. (PLATE 33.)

Hall marks. 1. Small black letter L in a plain shield. 2. Lion passant in a plain oblong. 3. Leopard's head crowned in a circle. 4. R. C., three pellets above and below within a dotted circle.

This cup has a straight-sided bowl swelling out into a bell-shaped lip, ending in a flat base. The stem, having above its middle a small round moulding on a narrow fillet for a knob, swells out at both ends. The foot ends in a round moulding and a flat edge, the lion passant is repeated underneath. On the bowl is: "*Hunc calicem cum operculo Henricus Firebrace Miles in usum ecclesie de Stoke Golding in agro Leicestr: D.D. anno Domi 1689.*"§

SILVER COVER PATEN with a foot. Weight 7 oz. Diam. 6 $\frac{1}{4}$ in. Diam. of the foot 2 $\frac{3}{8}$ in. Height of the foot $\frac{7}{8}$ in. Date 1688. (PLATE 33.)

No hall marks.

* "1654, 4th Nov., John Burdett, gent. and Elizabeth Ward, married." Peckleton Register. † See *Nichols*, Vol. iv., p. 866. ‡ Name of a farm in this parish, now owned by Mr. Cooper. § "This cup with the cover Sir Henry Firebrace, Knight, gave as a gift for the use of the church of Stoke Golding, in the county of Leicester, in the year of our Lord 1689."

This paten has a flat edge, the middle part being sunk flat. Round the inside edge is a vertical rim, causing the cover to fit on to the cup. The foot is a disk attached to the paten by a thick short round stem swelling out at both ends. On the foot is: "*Ecclesia de Stoke Golding. H. F. Anno Do 1689.*" This paten fits on to the cup both ways.

SILVER FLAGON. Weight 43 oz. Height 11½ in. Diam. at the top 4¾ in.; at the foot 7 in. Date 1688. (PLATE 33.)

Hall marks as on the cup.

This is a straight-sided flagon narrowing towards the top. Its lid is in the shape of a befeater hat, on the middle of which is a fluted disk, out of which rises a small round knob. The handle is of the usual shape, having the maker's mark stamped on the back, and ending in a shaped shield. There is also low down on the back of the handle, a small piece of metal, the same width as the handle, turned round so as to form a ring ¼ of an inch in diameter. In front of the drum is: "*Hanc lagenam unā cum fatinā Basilii Firebrace Miles, in usum ecclesie de Stoke Golding in agro Leicester; D.D. Annº Dno 1689.*"*

SILVER DISH with a foot. Weight 8.8 oz. Diam. 7¾ in. Diam. of the foot 3¾ in. Height of the foot 1¾ in. Date 1689.

Hall marks. 1. Small black letter M in a plain shield. 2, 3 and 4. As on the cup.

This is a plain flat dish with a raised edge. The foot is hollow, and ends in a flat edge, the lion passant being repeated below. Round the centre of the dish is: "*Ecclesia de Stoke Golding; B. F. Anno Dni 1689.*"

Nothing older than these pieces is mentioned in the terrier of 1709.

Sir **Henry Firebrace**, Knt., the donor of the silver cup and cover, was the 6th son of **Robert Firebrace**, of Derby, by **Susanna**, daughter of **John Hierome**, merchant of London, and was born in 1619. **Henry Firebrace**, a devoted royalist, was one of a small band of faithful attendants suffered to be about **Charles I.**, in his last years. He formed one of the limited court allotted to the King on his removal to Holdenby, his post being to "serve at the back stairs,"† and remained with his master till the end. At Carisbrook Castle **H. Firebrace** was the leading spirit in plotting many schemes for an escape, upon which subject several letters passed between the King and him.‡ He attended the King at the scaffold, who then gave to him a ring bearing his miniature set in diamonds, now in the possession of the Knight's descendant, the Earl of **Denbigh**. After the death of his royal master, **H. Firebrace** retired to Stoke Golding, where he had obtained a property with his wife, **Elizabeth**, daughter of **Thomas Davell** of this place, whom he had married in about 1641. In 1660 he was more successful than many others in obtaining a reward for past services, and was given the post of assistant to the officers of the green cloth, which he held through the reigns of both **Charles** and **James**. At the revolution he left the court for good, and retired once more to Stoke, "*aulā ut servaret fidem,*"

* "This flagon with one dish Basil Firebrace, Knt.," etc.

† Hist. MSS. Commission: Report 4. p. 274.

‡ For copies of which see *Nichols*, Vol. iv., p. 732.

lying here on 27th Jan., 1690-1. Sir **Henry**, who, by-the-bye, must have been knighted between the date of his will and his 3rd marriage, was buried in this church, in the chancel of which is a marble monument to his memory bearing a long latin inscription and his arms: *Azure, on a bend Or between two roses Argent three crescents Sable*.*

By his first wife, **Elizabeth**, Sir **H. Firebrace**, had with other children a daughter, **Susanna**, married in 1669-70, to **Thomas Hall**, of Elymore, Durham, and buried in 1715, aged 74.† His second wife was **Alice**, daughter of **Richard Bagnall**, of Reading, and widow of **John Bucknall**, of Creeke, co. Northants, which lady died on 31st Dec., 1675.‡ Sir **Henry** married thirdly in his old age, in 1685, **May**, daughter of **Richard Dalton**, and widow of **Lowde Cordell**, Esq.; she was buried in Westminster Abbey, on 1st Feb., 1687-8, three days before her infant daughter **Mary**.

In his will, dated 15th Dec., 1680, and proved P.C.C. 7th April, 1691, **Henry Firebrace**, "of Whitehall, in the parish of St. Martin-in-the-Fields, Esq.," left his house at Stoke Golding, and his lands there and in Sutton Cheney, to his eldest son **Henry**,§ and his heirs male; in default, to his son **Basil**, and his heirs male; to his daughter **Susanna Hall**, widow, and to her daughter **Elizabeth** £100 each; to **Charles** and **Hester**, children of his son **Basil** £100 each; to "sister **Firebrace**, of Ratcliffe," and her two daughters £5 each; to his aunt, Mrs. **Hester Hodges**,|| and to his sister **Abigail Dowell** £20 each. His sons **Henry** and **Basil**, executors.

Basil Firebrace, the donor of the flagon and dish, was the second son of Sir **Henry**, by his first wife, **Elizabeth Davell**, and was born in 1653. He was a merchant of London, and possessed at one time considerable wealth; in 1687 he was sheriff of the city, and churchwarden of All Hallows, Barking, and was knighted on 2nd Aug. in the same year. Sir **Basil** was created a baronet on 28th July, 1698. After having lived to spend, according to **T. Hearne**, his fortune and his latter years in a not very creditable way, he died on 6th June, 1707.¶ Sir **Basil Firebrace** married at St. Margaret's, Westminster, on 7th Sep., 1671,** **Elizabeth**, daughter of **Thomas Hough**, merchant of London, by whom he had a son and successor, **Charles**, with whose son **Cordell**, the baronetcy became extinct. Sir **Basil's** daughter, **Hester**, married **Basil**, 4th Earl of **Denbigh**, from whom descends the present Earl.

DADLINGTON.

SILVER CUP. Weight 4.3 oz. Height 5 $\frac{3}{8}$ in. Diam. of the bowl 3 $\frac{1}{4}$ in.; of the foot 3 in. Height of the stem 2 $\frac{1}{2}$ in. Date 1573. (PLATE 31.)

One mark only; a plain cross between four pellets within a dotted circle.

This little cup has a bowl shaped into an inverted truncated cone slightly concave, round its upper part is a band of Elizabethan foliage, divided into eight parts by hour-glass curves.

* See *Nichols*, Vol. iv., p. 720. † Westminster Abbey Registers. *Hart. Soc.*, Vol. x., pp. 5 & 220. ‡ *Bridges Hist. of Northants.*, Vol. i., p. 561. § D.D. and Fellow of Trinity Coll., Camb., alive in 1702; died unmarried. || Founder of Free School here. * Hearne's Collections: *Oxford Hist. Soc.*, Vol. vii., p. 18. ** Parish Register.

The bottom of the bowl is flat and projecting, with lines running round its edge. At the top of the stem, instead of the usual vertical edge, is a narrow neck and a disk divided into fifteen parts by radii; below which is the main part of the stem divided in the middle by a small knob, and swelling out at both ends. The foot, which is of the usual shape, has round its upper part a band of foliage, divided into four parts by hour-glass curves. Underneath the foot is engraved the date "1573," the initials "R. P.," and I think also the weight. About five years ago the dints were beaten out of this cup, and a deep crack in the lip mended. The date under the foot, which is known to have been there for some years, has every appearance of having been engraved when the cup was made. The initials are possibly those of either the maker or retailer. This cup was made by the same maker as the Swepston and Sutton Cheney cups.*

SILVER PATEN. Weight 3.5 oz. Diam. $5\frac{1}{4}$ in. Date 1880.

London hall marks.

This is a flat paten made to fit on to the old cup. In the centre is a cross within an ornamental circle.

SILVER PLATED FLAGON. Height 8 in. Diam. at the top $1\frac{1}{8}$ in.; at the foot $2\frac{3}{4}$ in.

This is a miniature jug-shaped flagon of the usual modern shape, its lid being surmounted with a cross.

PEWTER PLATE. Diam. 9 in.

Marks. 1. On the edge, T. B. C. 2. Underneath, "T. Letherbarrow" in an oblong. 3. In four small squares; (a) Lion passant. (b) Leopard's face. (c) Cock. (d) I. H.

PEWTER PLATE. Diam. $8\frac{1}{4}$ in.

On the edge is: "D. G."

This was formerly used as a paten.

In the terrier of 1709, there is this short notice of the communion service here; "A silver bowl bought by the town, about 9 oz. in weight." Knowing the weight of plate as recorded in the terriers to have been inexact and generally in avoirdupois, I should say this notice refers to the little cup still here, and that it then had a cover to it. The cup may have been purchased second-hand; but it is more likely that the old churchwardens' accounts of 1573 were in existence when the terrier was made.

The silver paten and plated flagon were presented to this church by the Rev. H. J. Lomax, vicar of the parish.

THORNTON.

SILVER CUP. Weight 11 oz. Height $6\frac{1}{2}$ in. Diam. of the bowl $4\frac{1}{2}$ in.; of the foot $4\frac{1}{8}$ in. Height of stem $3\frac{1}{4}$ in. Date *circa* 1600. (PLATE 31.)
No hall marks.

This cup has a bowl shaped into an inverted truncated cone with a convex base. Round its middle is a band of stroke ornament without straps or curves. The bowl rests on a narrow neck under which is a disk, divided into sixteen parts by radii, every other division is narrower and ornamented with zigzag lines. Below the disk the stem swells out slightly into the foot, which is flat at the top and has the usual vertical and flat edge, a reed ornament running round the former. All round the bowl, $\frac{1}{2}$ an inch from the lip, is a projecting groove about $\frac{1}{4}$ of an inch wide, and $\frac{1}{8}$ of an inch deep. To all appearance this groove was purposely beaten out; possibly in order to check the flow of wine when the cup is tilted too high.

TWO PEWTER PLATES. Diam. of each $8\frac{3}{4}$ in.

Marks. 1. X crowned. 2. Rose crowned, illegible name above, "London" below; repeated twice. 3. "London" in an oblong. 4. I. B. E. H.

BRITANNIA METAL FLAGON. Height $13\frac{3}{4}$ in. Diam. at the top $3\frac{5}{8}$ in.; at the foot 7 in.

J. Dixon, Sheffield.

This is a tall straight-sided flagon, narrowing to the top.

BAGWORTH.

SILVER CUP. Weight 6.6 oz. Height 6 in. Diam. of bowl and of foot $3\frac{1}{2}$ in. Height of stem $2\frac{3}{8}$ in. Date 1638. (PLATE 31.)

Hall marks. 1. Court-hand A in a plain shield. 2. Lion passant. 3. Leopard's head crowned; each having an outer line. 4. E. M. in a shaped shield.

This little cup has a straight-sided bowl swelling into a bell-shaped lip, and having a flat base. Its stem is plain and round, 1 inch thick in the middle, swelling out to the bowl and into the foot, which is rounded off into a wide flat edge. The lion passant is repeated under the foot.

TWO PEWTER PLATES. Diam. of each 9 in.

Marks. 1. X crowned. 2. An eagle rising out of a ducal crown towards sun in splendour. 3. "London." 4. In four small shapes; (a) "B and V." (b) Sun in splendour. (c) On a wreath an eagle's head erased. (d) Per chevron engrailed, three eagles' heads erased.

These plates have flat edges 1 inch wide, the middle part being sunk 1 inch in depth.

BRITANNIA METAL FLAGON. Height 14 in. Diam. at top $3\frac{3}{8}$ in.; at foot $6\frac{1}{2}$ in.

Mark. "Dixon and Sons."

This is a tall straight-sided flagon, narrowing to the top.

Both this and the Thornton flagon were given by the late Rev. S. Adams, vicar of the parish.

"Truly," said Sir Percival. "I saw a damsel, as me-
thought, all in white, with a vessel in both her hands,
and forthwithal I was wbole."

